

Basic of Li-ion Battery Charger and Solution for portable device

Agenda

- What is a Li-ion battery charger?
 - Basic of charger
 - Linear charger vs Switching charger
 - Non power path vs Power path
 - Other functions
- TI charger solutions for portable device
 - Low power charging solution for wearable device
 - Fast charging solution

Battery Electrical Equivalent Circuit

Battery DC model

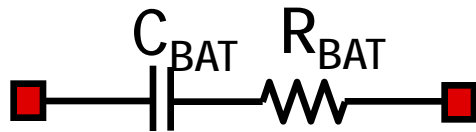

Constant current discharge, transient effect

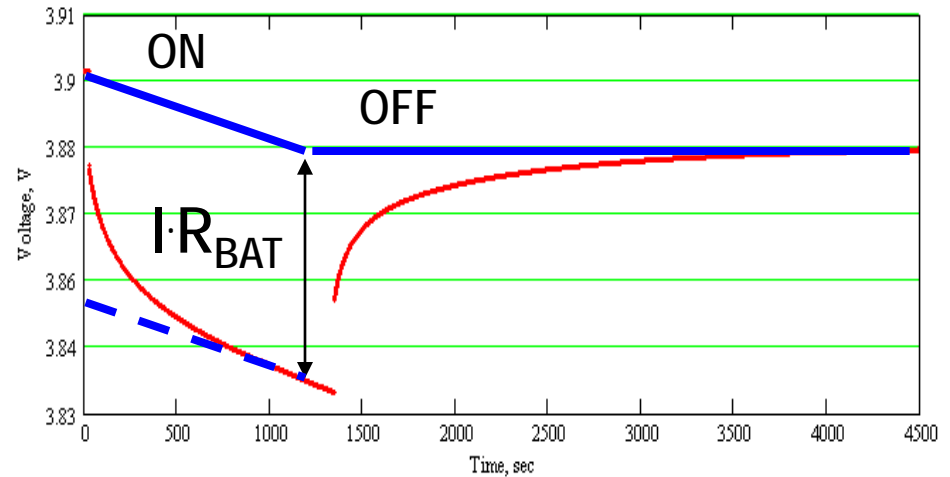

- Capacitor
- - - Capacitor + resistor
- Battery

What is Charger?

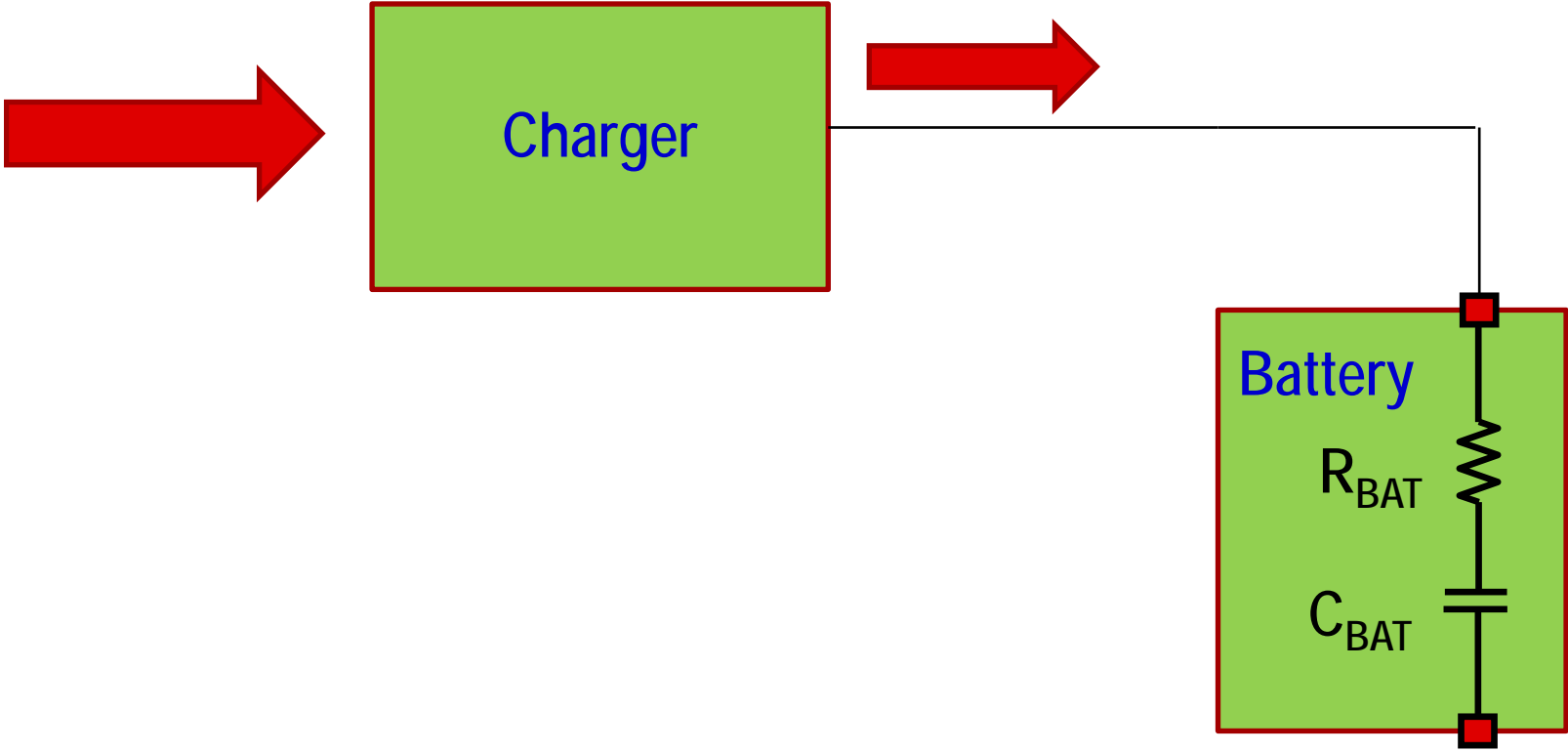

What is Charger?

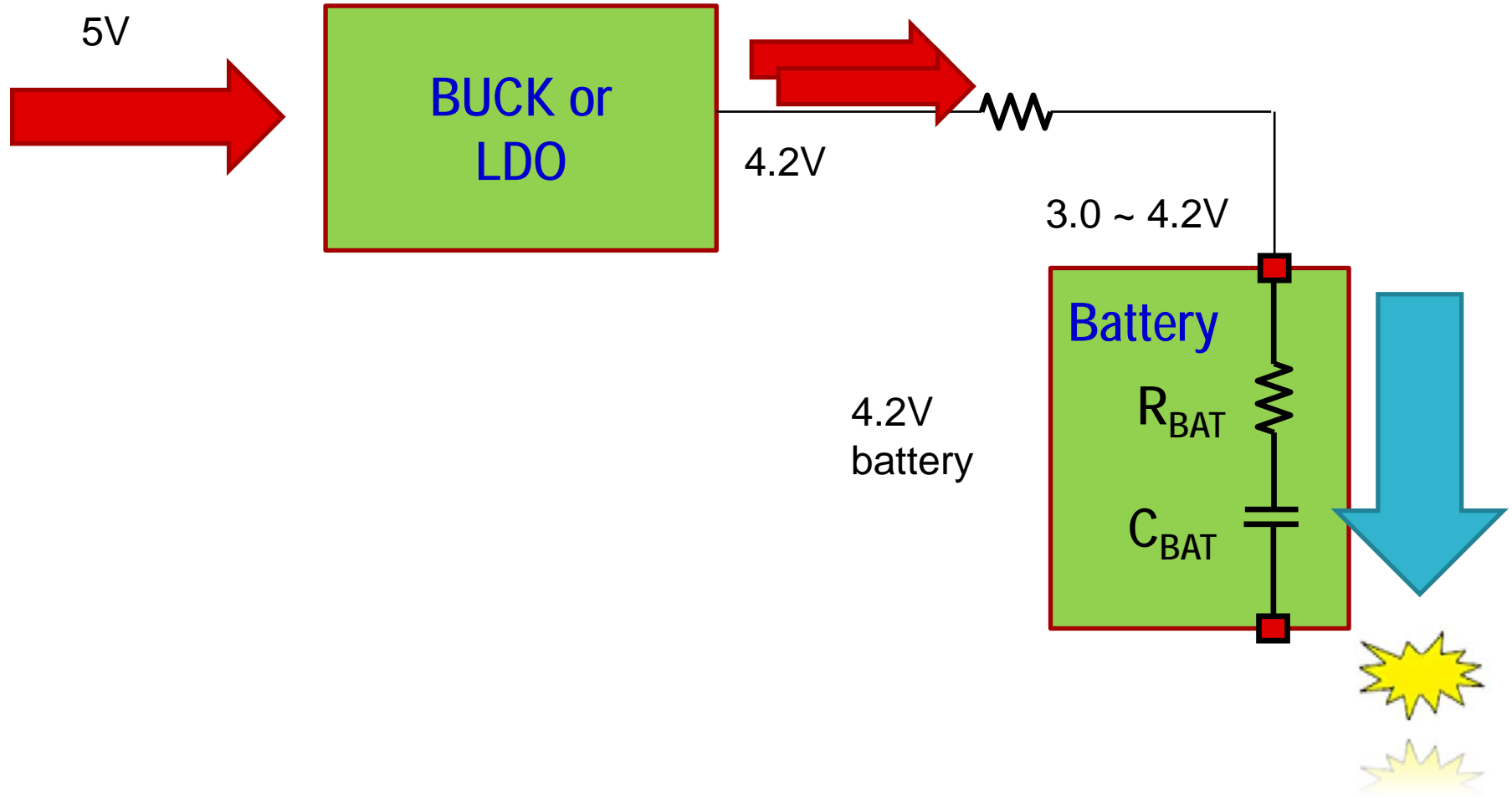

What is Charger?

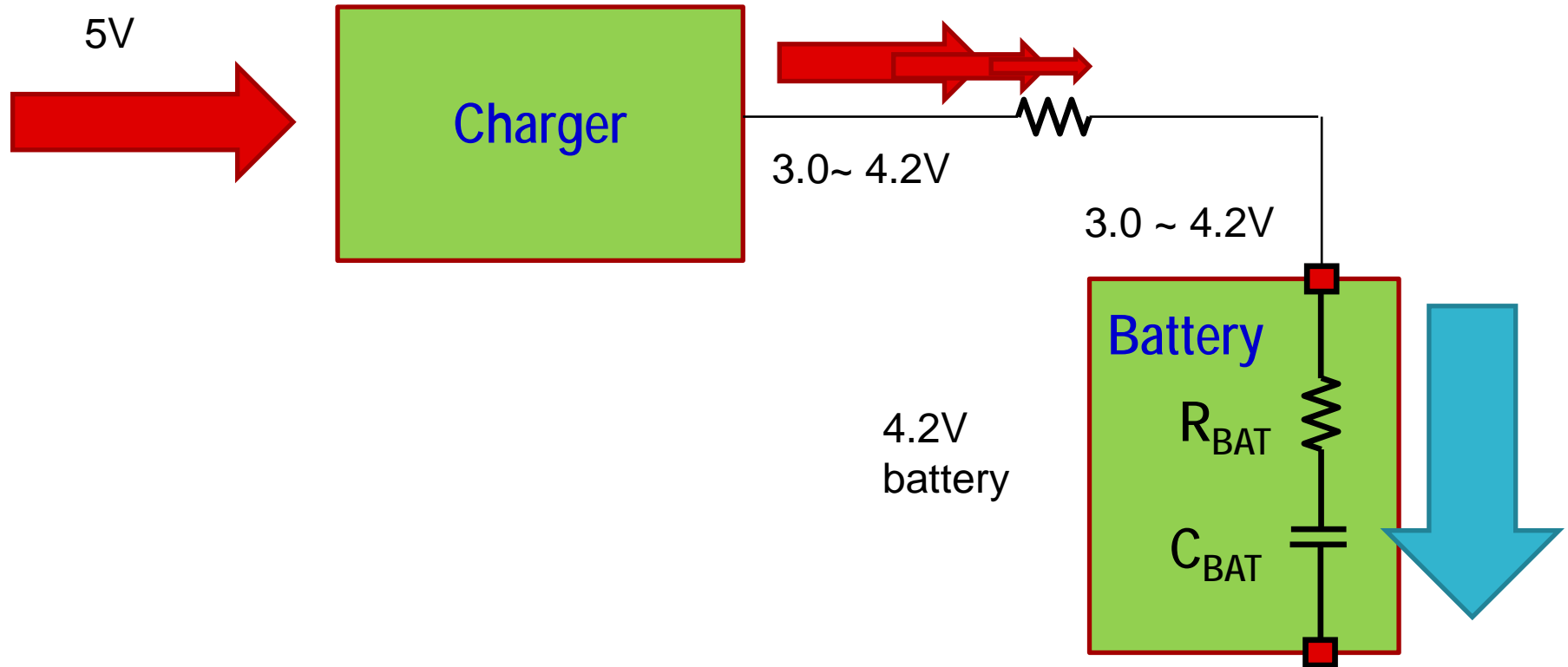

Li-ion battery charging profile

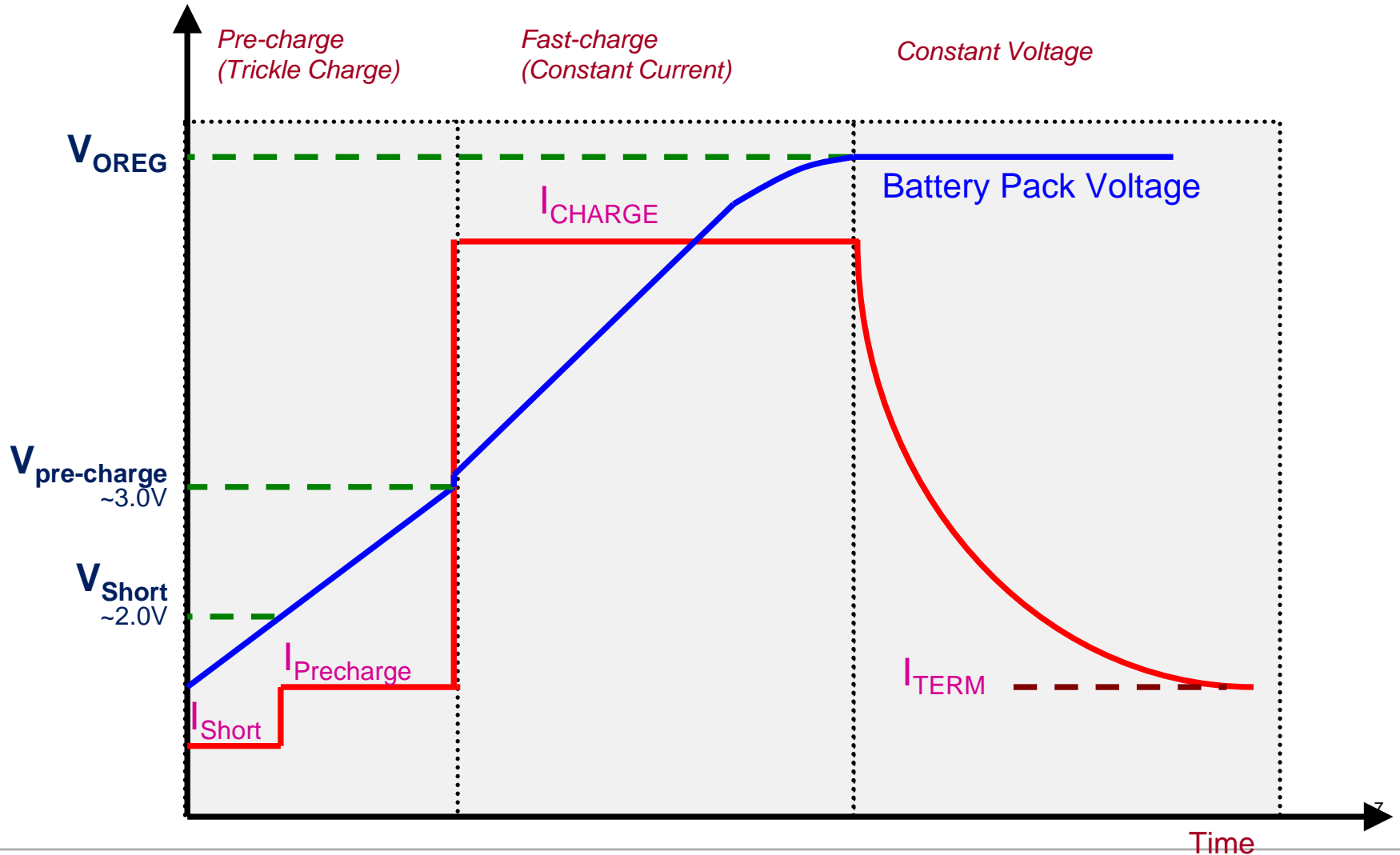

Charger Architecture

Linear vs. Switch-mode Topologies

Linear

- Recommended for designs with charge current less than 1.5A
- Simple Design
- Small Size compared to switching circuits
- Fewer external components translates to lower application cost
- Less efficient. Efficiency is directly correlated to the battery voltage

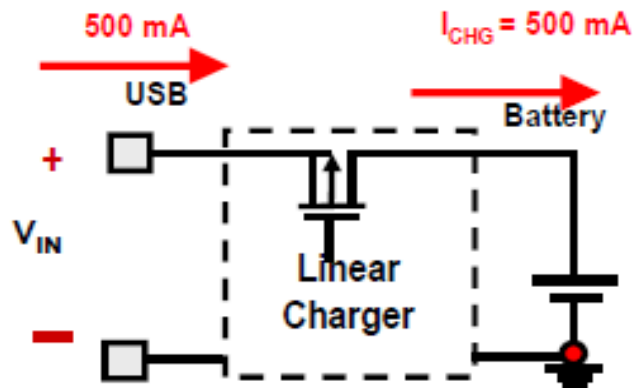

Switch-mode

- Recommended for designs with larger charge currents (*1.5A and above*)
- More complex design
- Highly efficient solution, with very little dependency of the battery voltage on the efficiency
- Power conversion allows higher output currents for a given input current

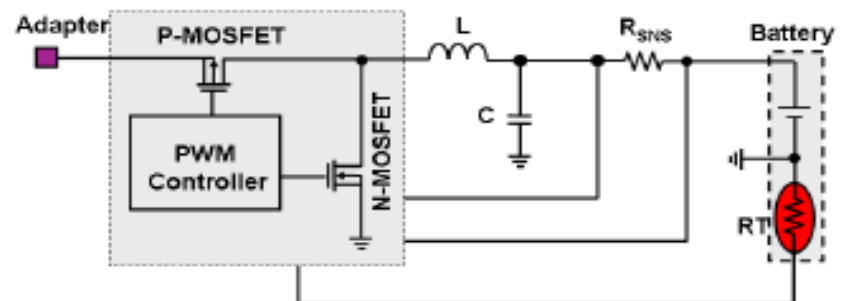

Charging

Power Path vs. Non Power Path Topologies

Non Power-Path Topology

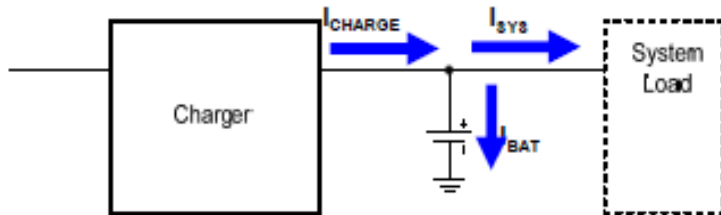

- The system voltage is always equal to the battery voltage
 - No system startup for deeply discharged batteries
- I_{CHARGE} is always split between I_{BAT} and I_{SYS}
 - I_{CHARGE} must be programmed to the maximum charge current for the battery cell
 - If $I_{\text{SYS}} >$ Termination current, then termination will not occur
- I_{BAT} is reduced for any system load
 - Reduced charge current extends charge time. Safety timers may expire prematurely

Power-Path Topology

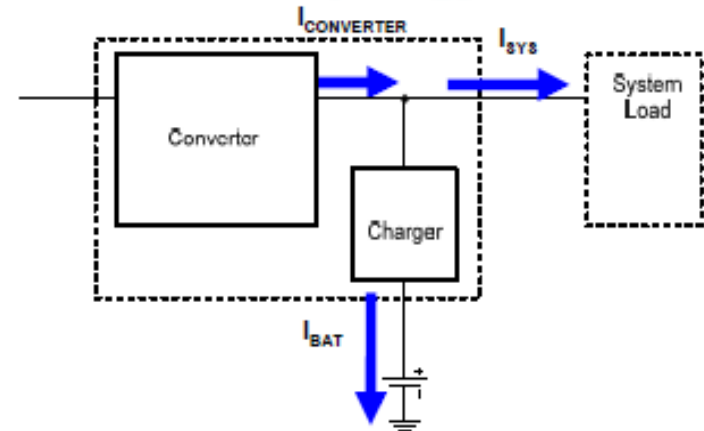

- $I_{\text{CONVERTER}}$ is set to maximize the current from the source.
 - More available current to system and battery charging for faster charge time
- I_{BAT} is set independent of $I_{\text{CONVERTER}}$
 - For low system loads, $I_{\text{CONVERTER}}$ is reduced to maintain proper charge current
 - I_{BAT} is always known by charger
 - Accurate termination current
 - Safety timer extended when charge current is less than programmed value

Charging

Power Path Examples

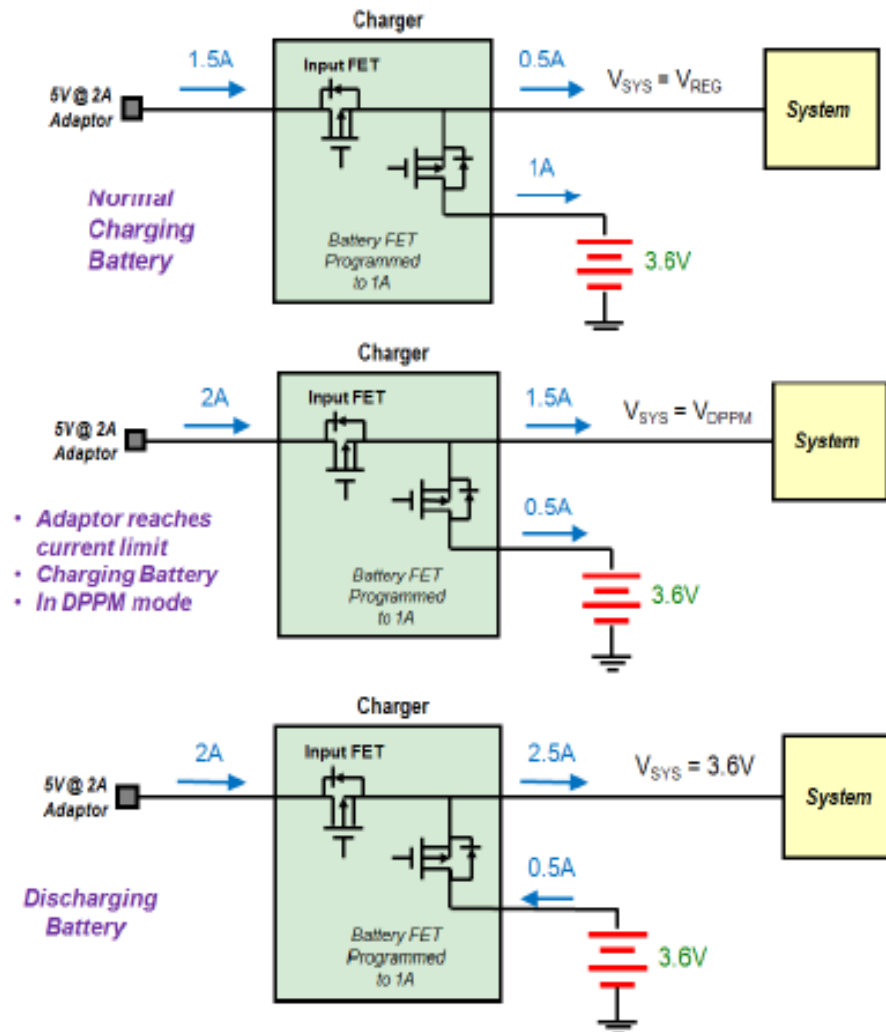

Normal Charging

- Adaptor powers the system
- Provides full charging

Max Adapter Current mode

- Adaptor powers system
- Charges battery in DPPM mode (I_{CHG} reduced)

Battery supplement mode

- Battery and adaptor power the system
- Discharging battery as providing supplement current to system

Charging

Power Path Examples – Dual Input

Dual Input Setup

Adapter & USB sourcing topology ($V_{SYS}=4.4V @ 500mA$)

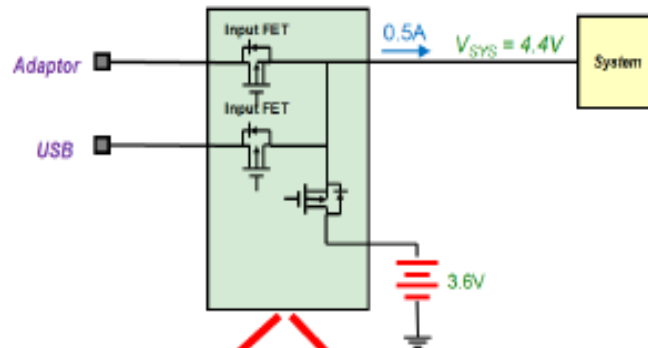

AC Adapter Input Sourcing

Battery Charging with excess current

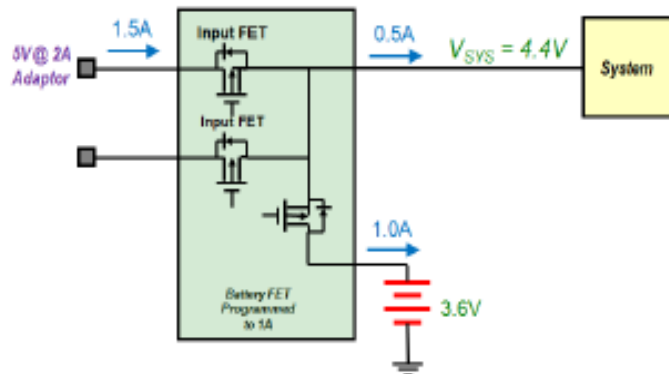

USB Input Sourcing

Battery supplements system current needs

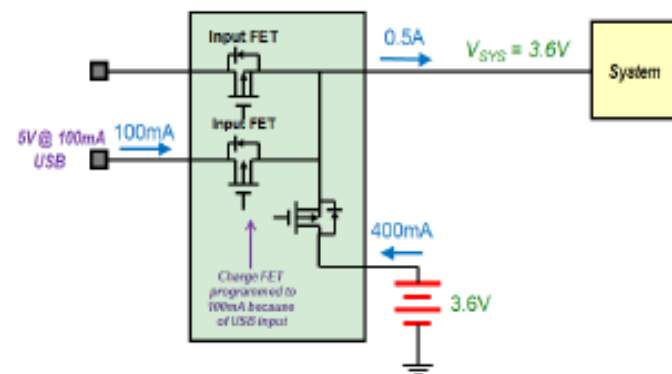

Charging

Current Capabilities of Adapters

- **Power sources have their limits**
 - There are situations where the input power source **does not have enough power** to supply what the portable device demands
 - Becoming increasingly important with the **standardization of input connectors** such as the Micro-USB
 - Input Voltage and Input Current Dynamic Power Management (V_{INDPM} & I_{INDPM}) provide the functions needed to solve this problem

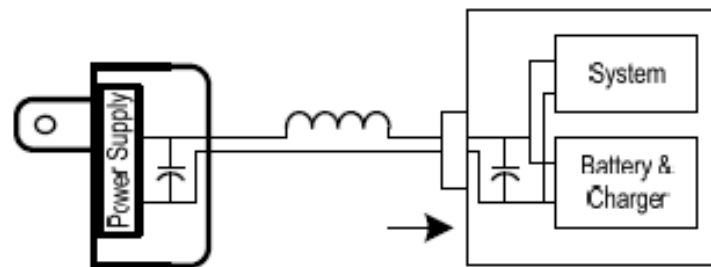

Charging

Dynamic Power Management (DPM)

- **Maintains useable system voltage with deeply discharged battery**
- **Allows smaller, less expensive adaptor**
 - *Average current vs peak currents*
- **Allows system operation without battery**
- **Protect against brownouts**
- **Protect against incorrect adaptor**

- **Input Voltage DPM - V_{IN_DPM}**
 - For input power source with unknown current capability
 - Fully utilize the power source capability
 - Dynamically reduces charge current to regulate minimum adaptor voltage
- **Input Current DPM - I_{IN_DPM}**
 - For input power source with known current capability
 - Input current limiting
 - Dynamically reduces charge current to regulate maximum current from the input adapter
- **Output Voltage DPM - V_{OUT_DPM}**
 - aka "Dynamic Power Path Management" (DPPM)
 - Monitors output voltage
 - Reduces charge current to maintain minimum system voltage

Charging

USB On The Go (OTG) Support

- Switch-mode charger can be re-configured to support boosting back the battery voltage to the USB input to power up an accessory
- Allows re-use of the same IC to both charge the battery (buck) and power an accessory (boost)

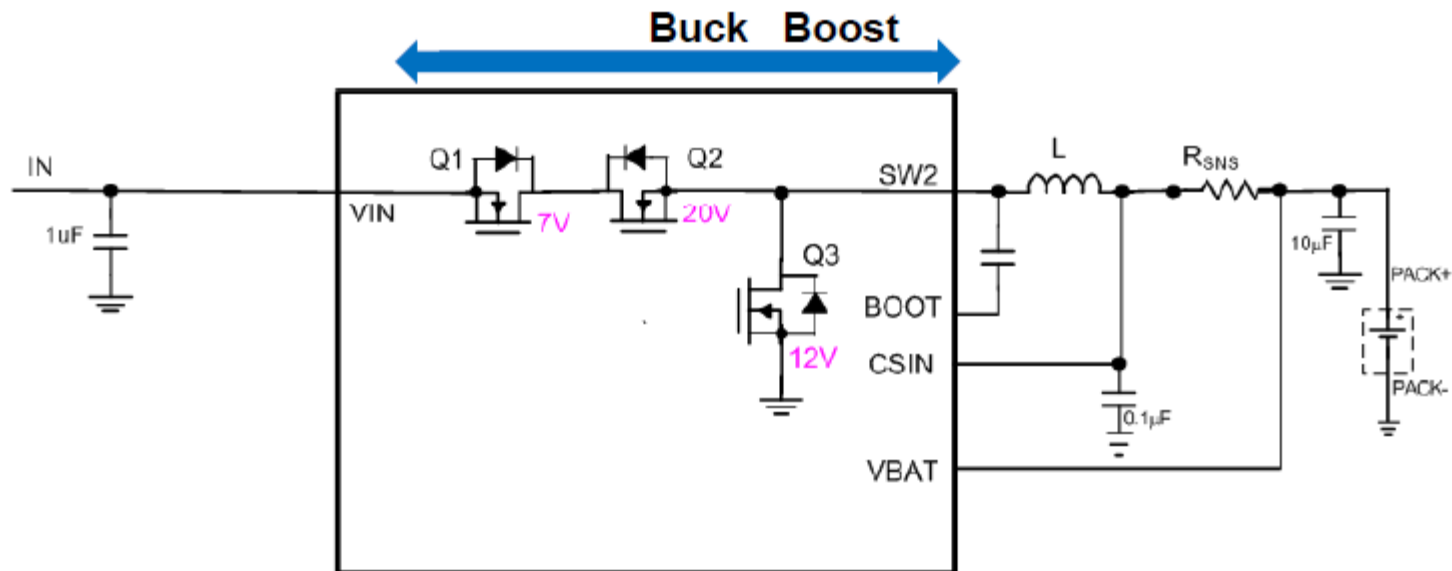

Summary

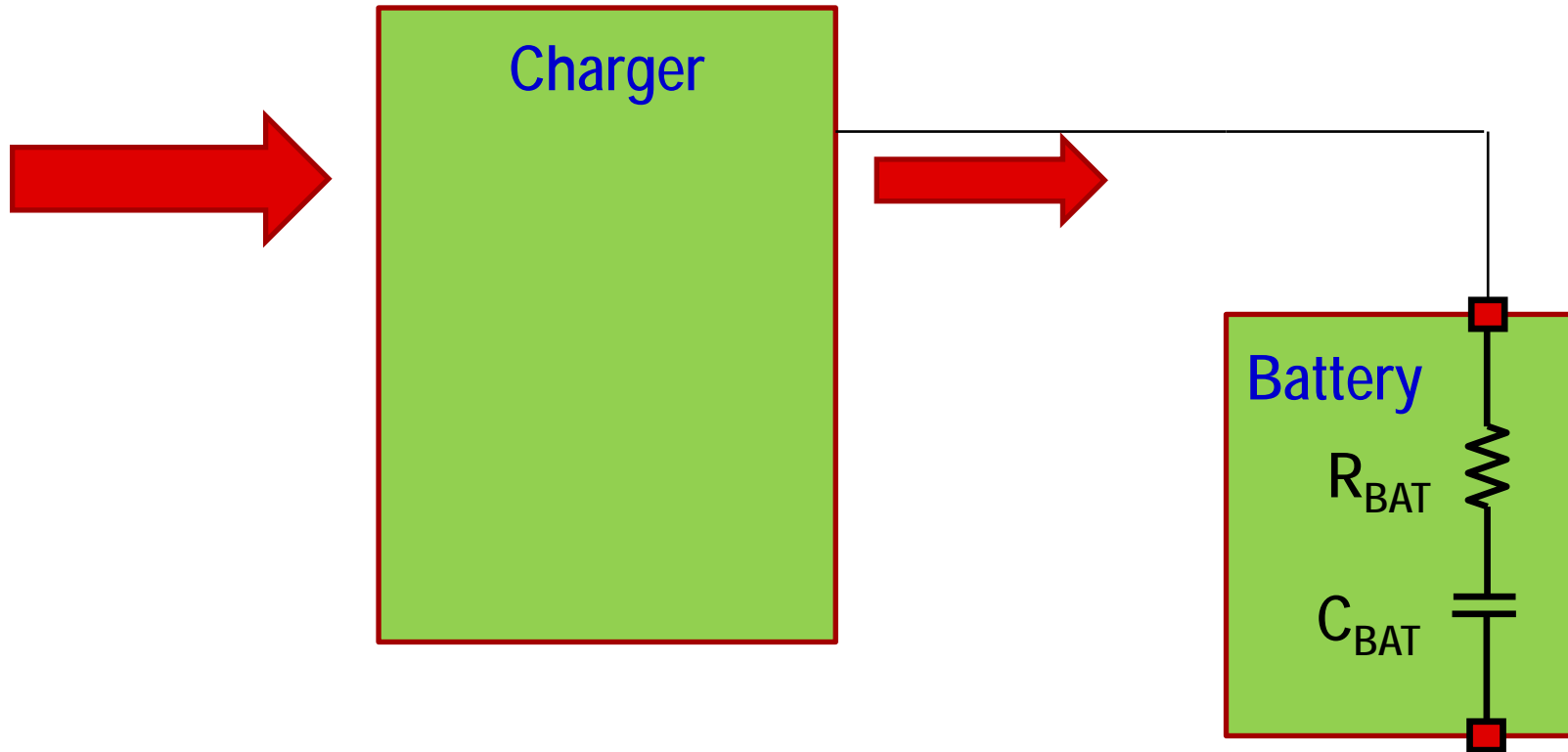

Summary

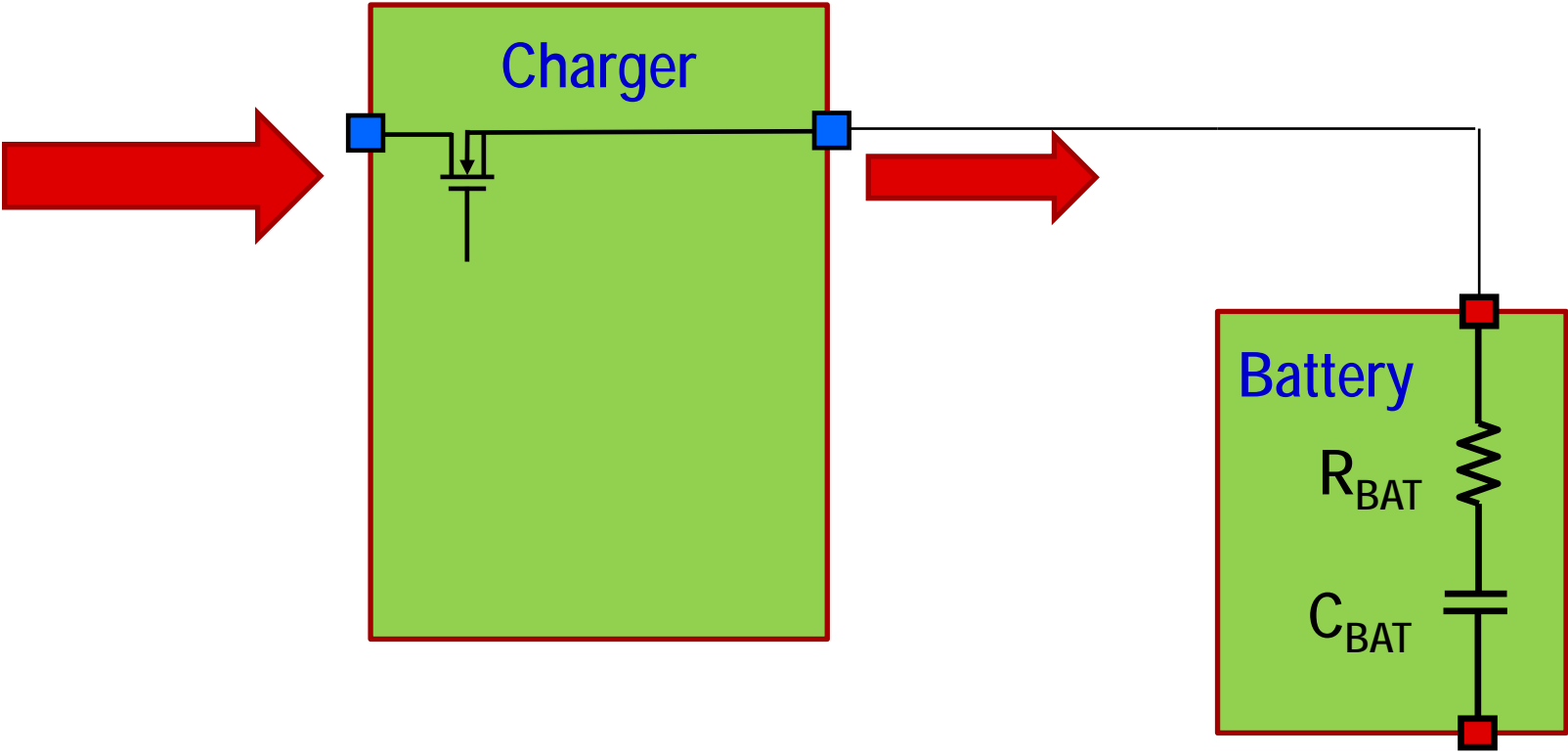

Summary

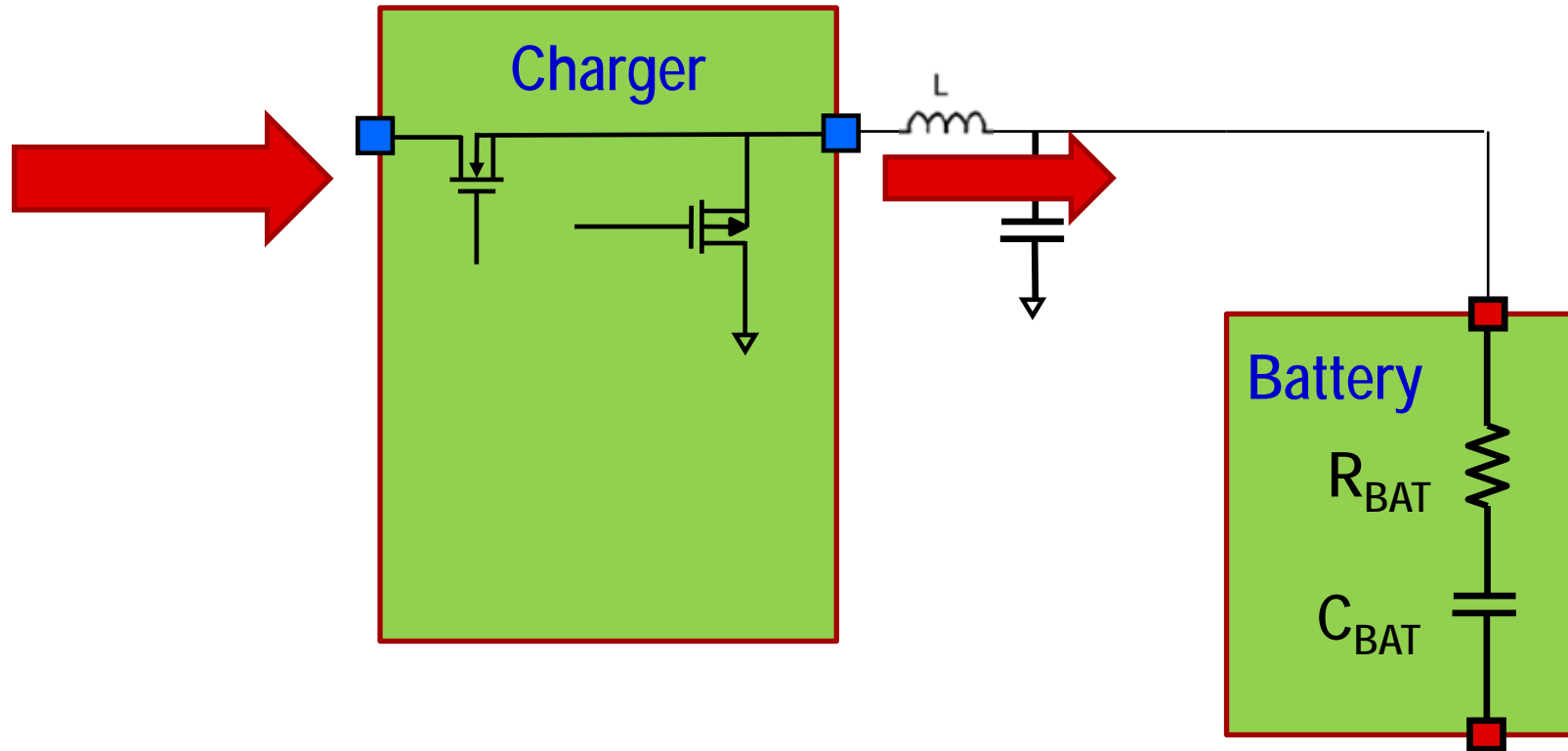

Summary

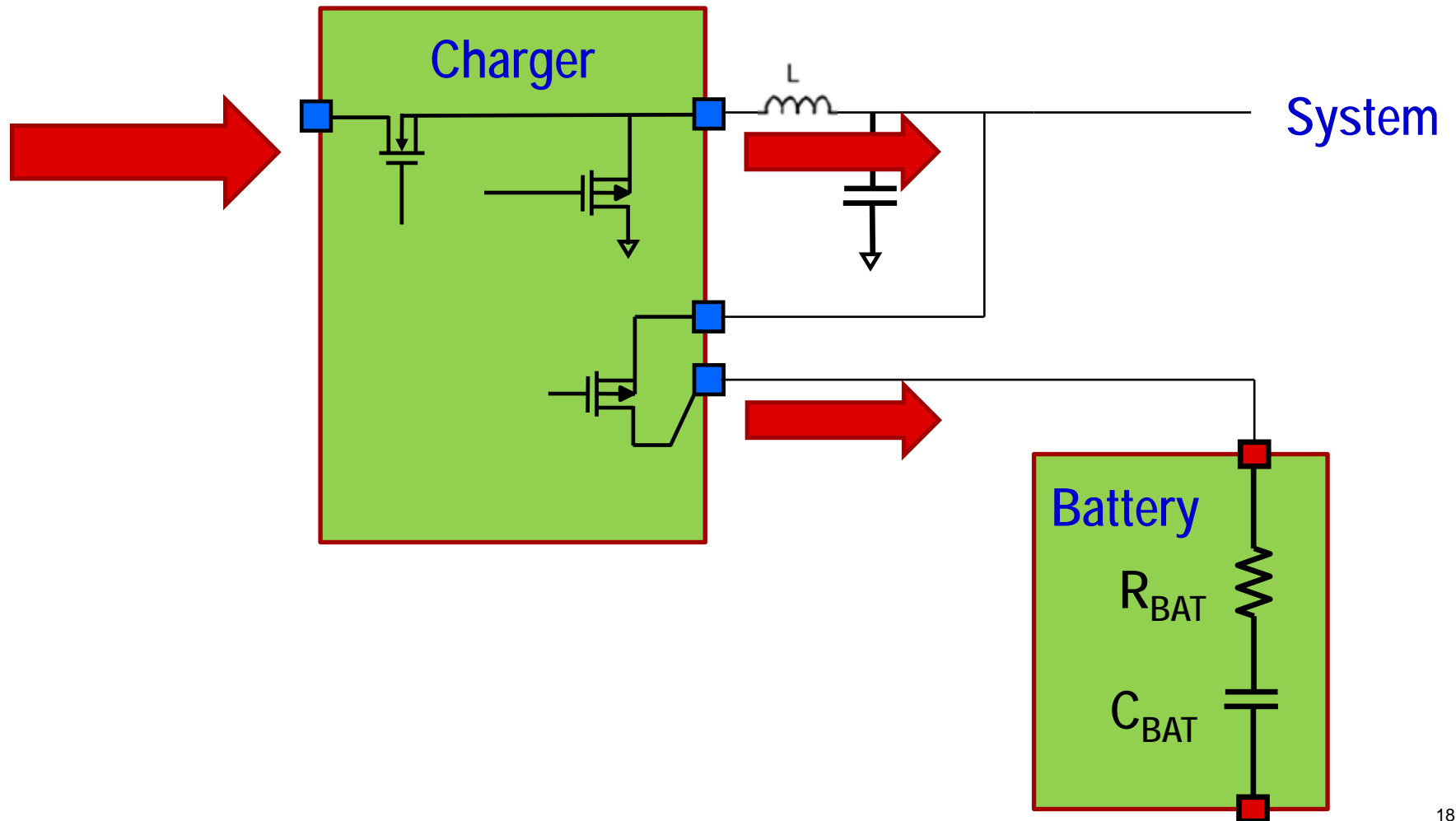

Summary

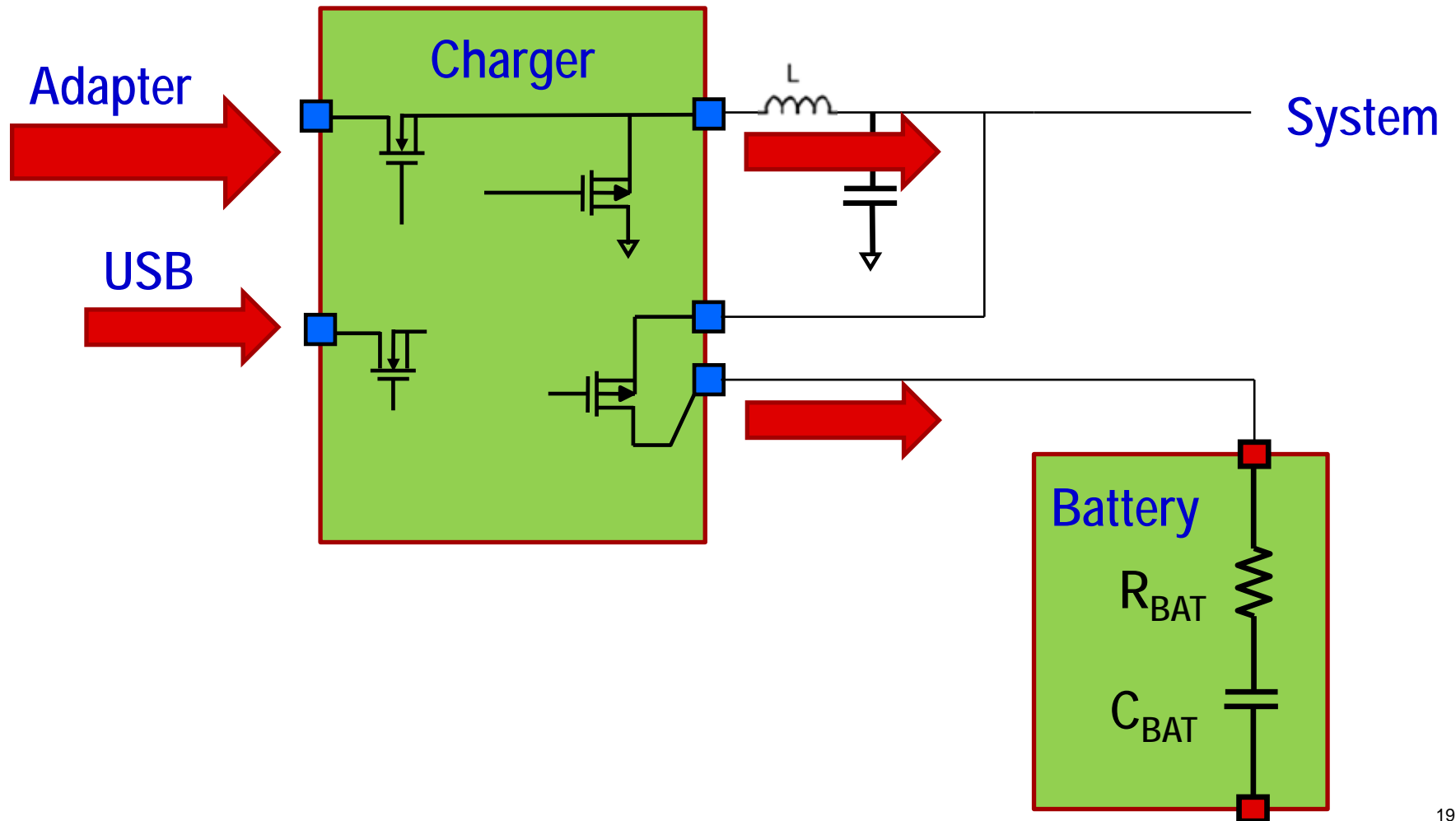

TI Charger solution for portable device

Wearable Charging Solution

Accurate Charger

- Small size & leakage I
- Low charging current
- Low taper current
- Accurate charging V

Normal Charging Solution

Normal Charger

Fast Charging Solution

High Current Charger

Dual Charger

MaxLife Solution

Batteries for Wearables

- The Battery Compromise
 - Capacity - Typical is 30mAh to 300mAh
 - Energy Density – $\sim 150\text{mAh}/\text{cm}^3$
- Most popular Batteries for Wearables
 - Primary Li-Metal – Standard CR2032, highest energy density, but must be replaced by user

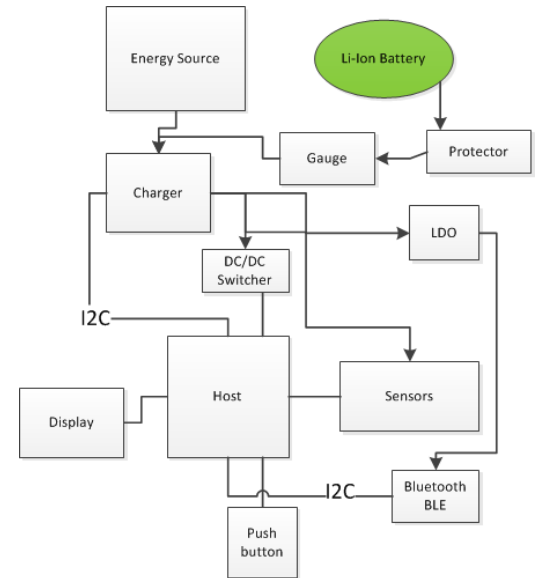

- Rechargeable Li-Ion – Most popular, able to get in various sizes, shapes, and capacities

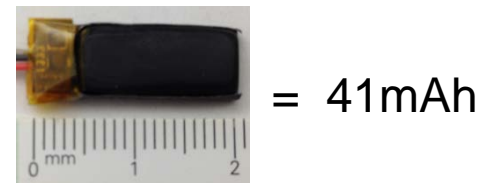
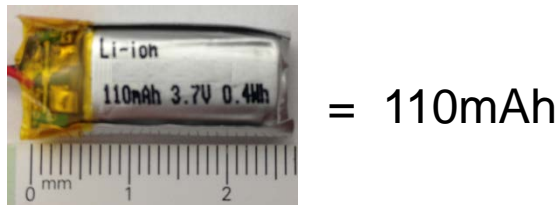

Li-Ion CC/CV Charging Profile – Challenges at Ultra-Low Power

“Fast Charge” level may be 10 – 300 mA, compared to 1A or higher for typical “portable” devices

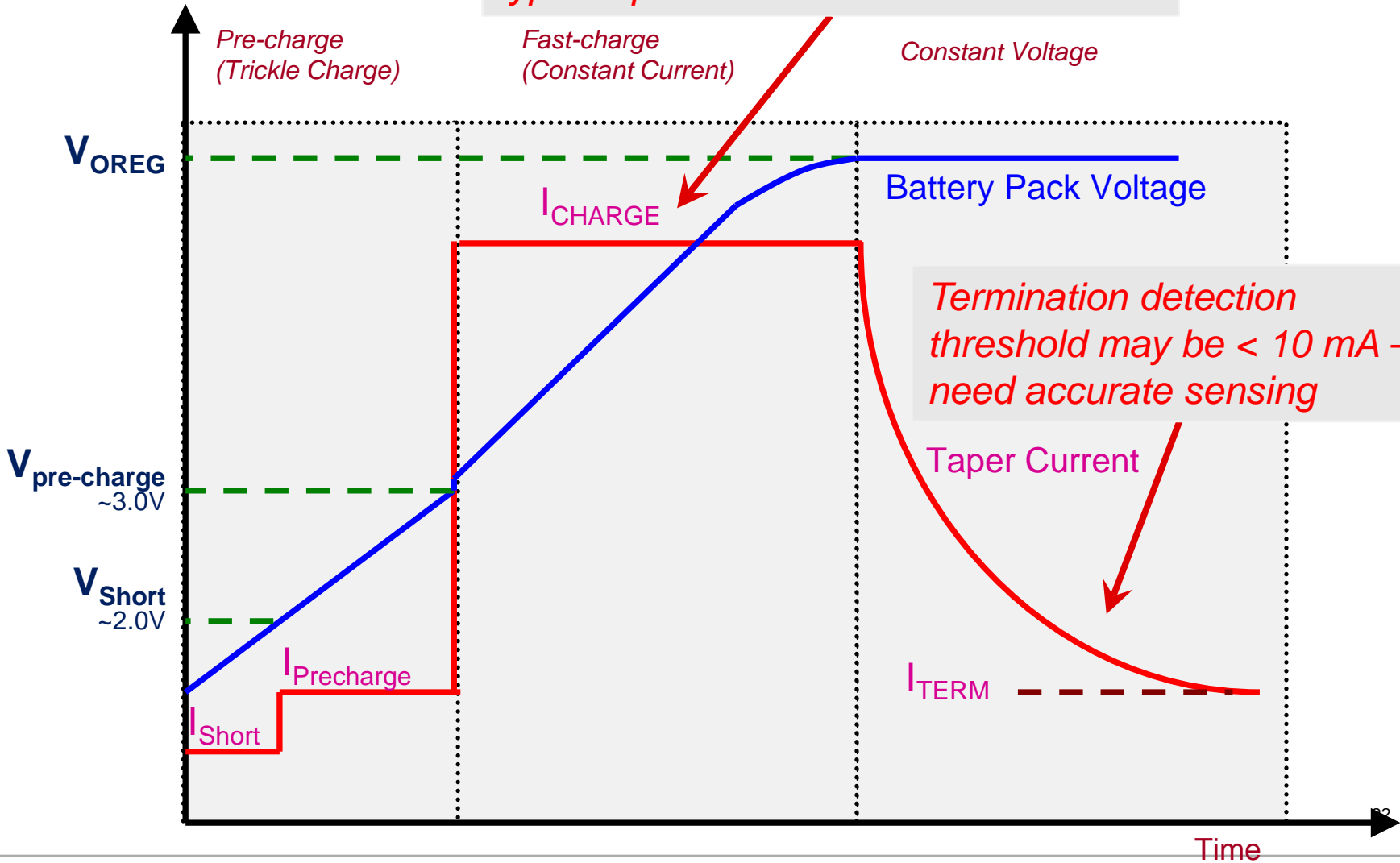

Accurate Small Cell Charge Termination

V_{BATT} (Volts)

I_{BATT} (mA)

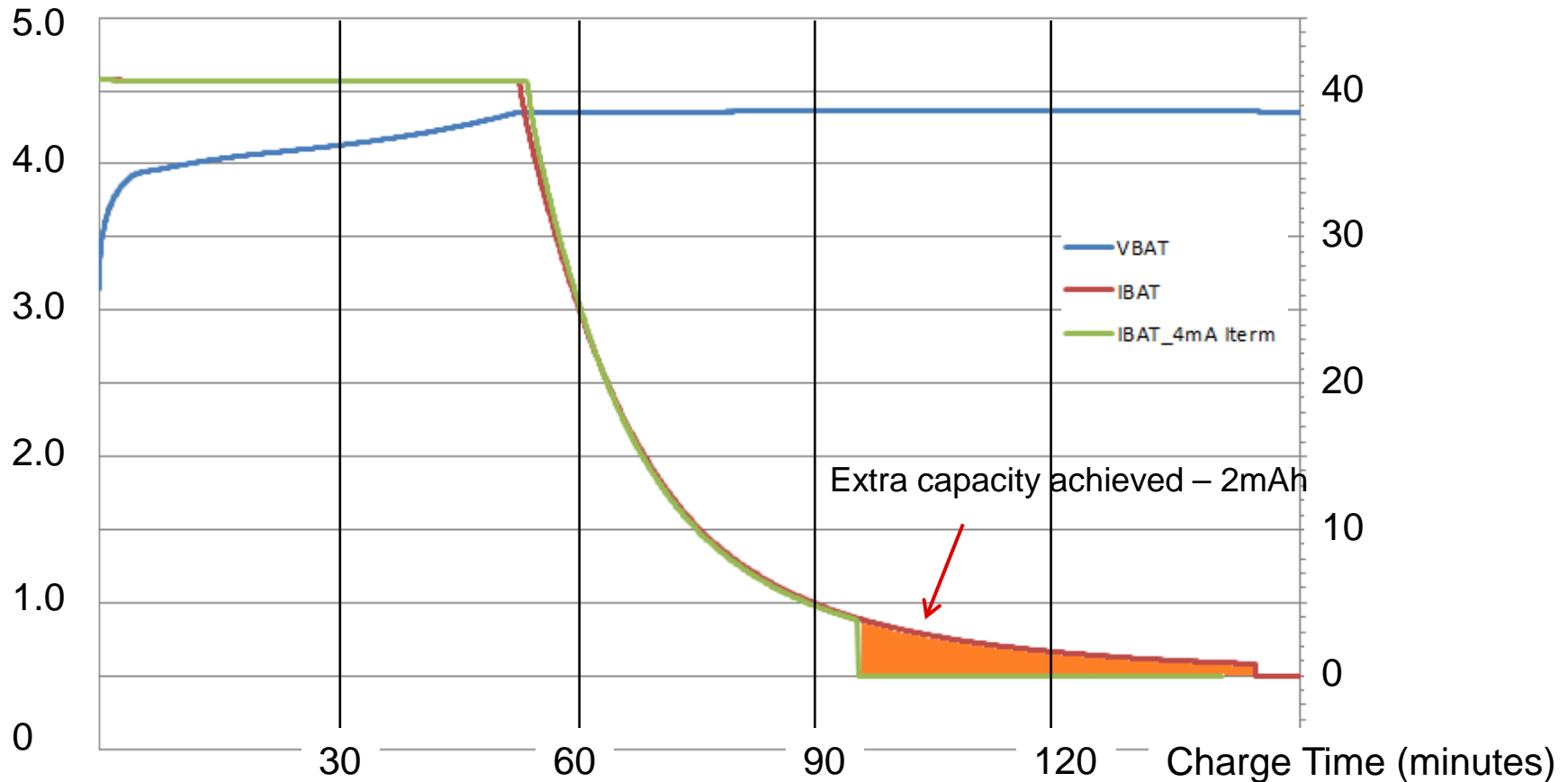

- Charged 41 mAh battery at 40 mA fast charge current (1C)
- Termination at 4 mA (10%) or 1 mA
- Shaded area represents additional 5 – 10% capacity restored on each charge

23

Dual Charger for fast charging

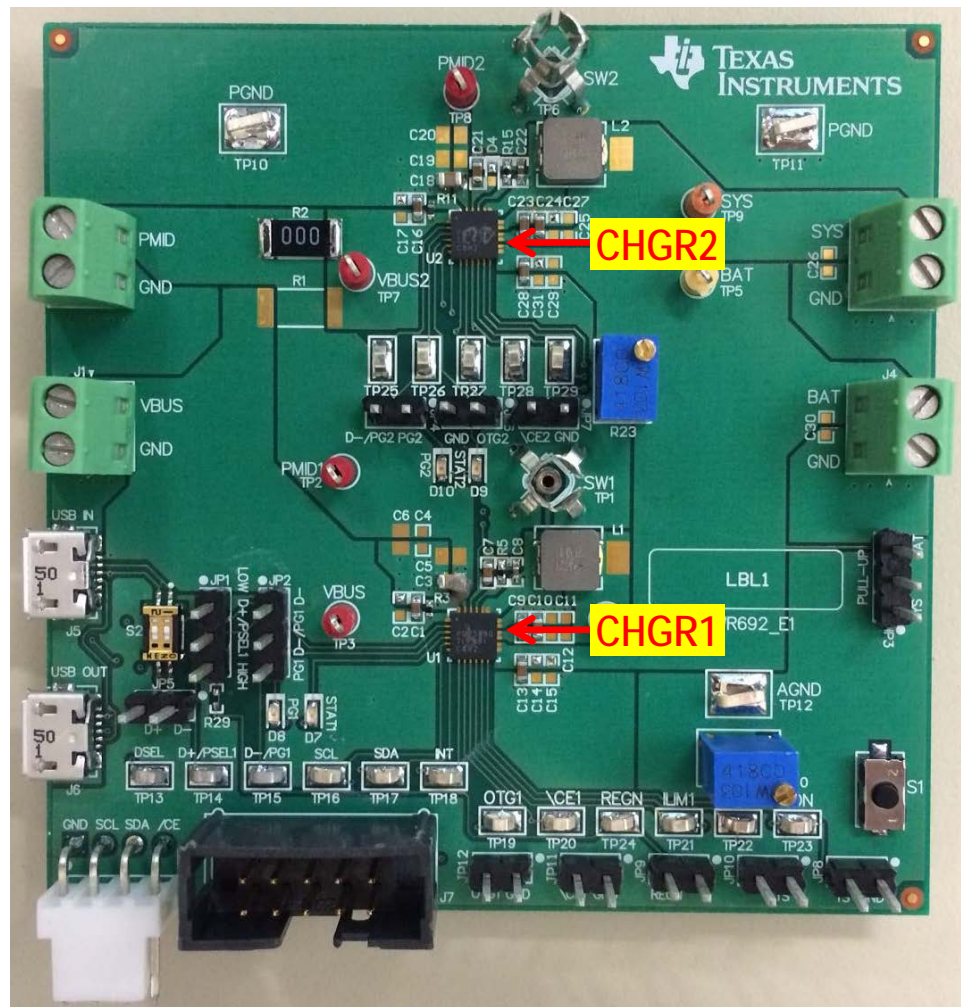
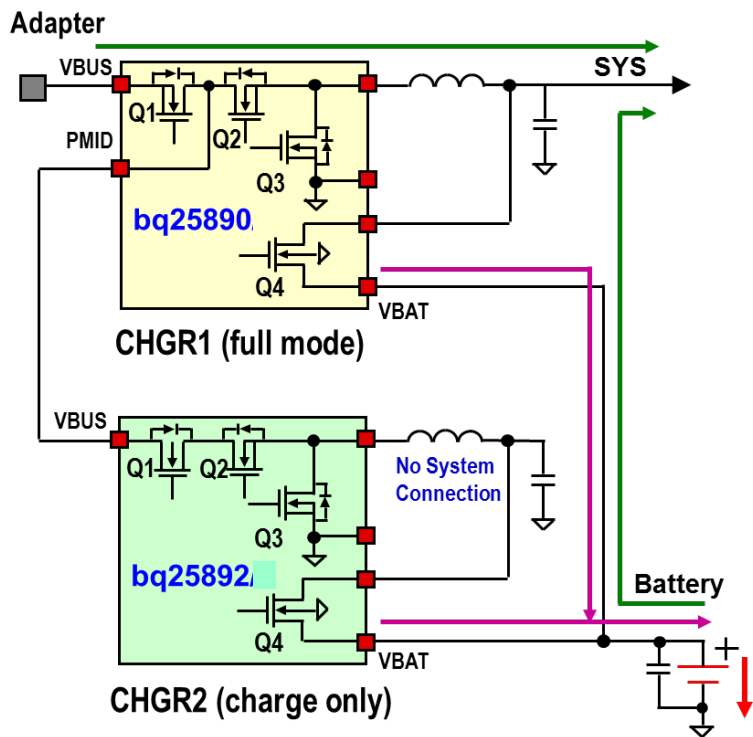

Dual Charger Chargers Selection

Charger 1 (Main)	Charger 2 (Slave)
PMIC	bq25898S (WCSP)
bq25898(D) (WCSP)	bq25898S (WCSP)
bq25890 (QFN)	bq25898S (WCSP)
bq25890 (QFN)	bq25892 (QFN)

Battery Impedance

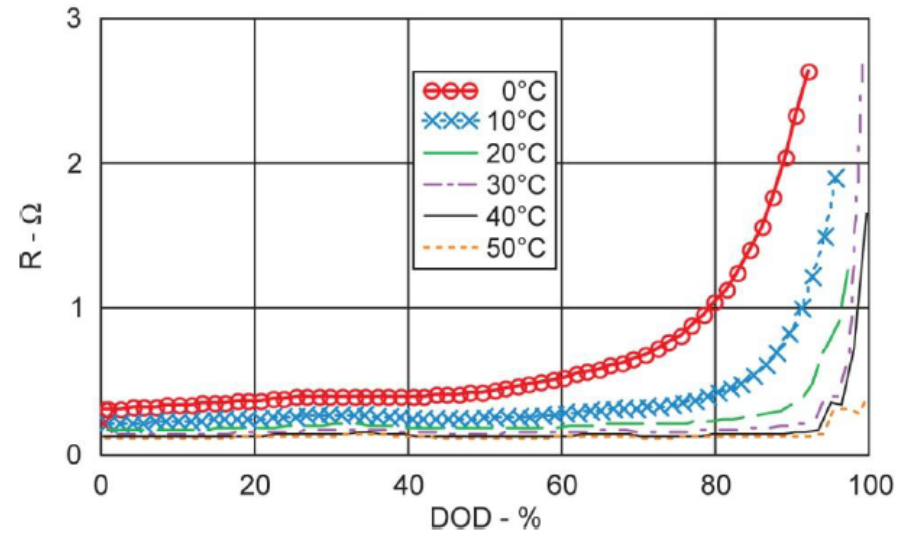
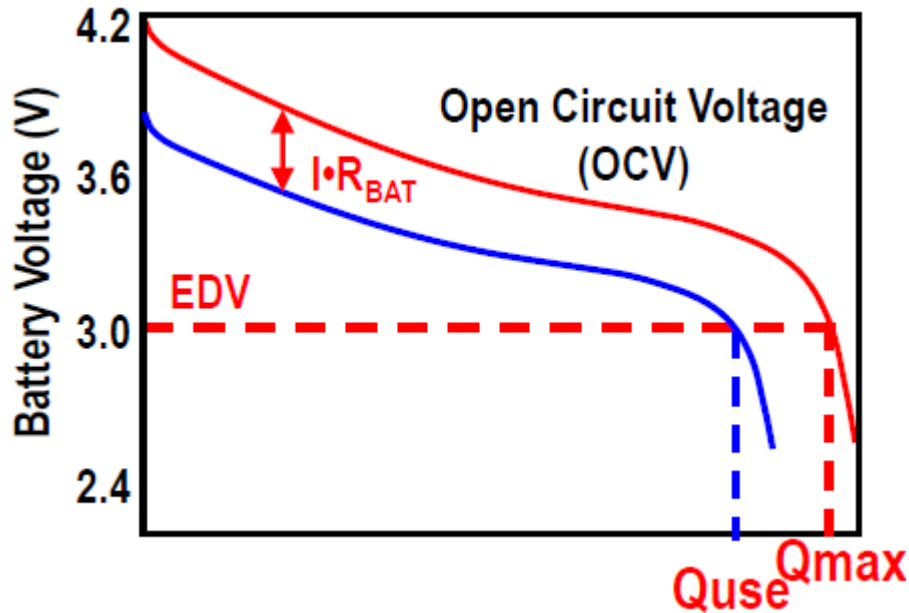

- Impedance affects usable capacity of the battery
- Capacity changes under different load/temperature conditions
- Dependent on Temperature, SOC, and Aging
- Doubles after 100 Cycles
- 10 ~ 15% Cell to Cell variation
- 10 ~ 15% variation among manufacturers

Li-plating caused by resistance increase of an aged cell

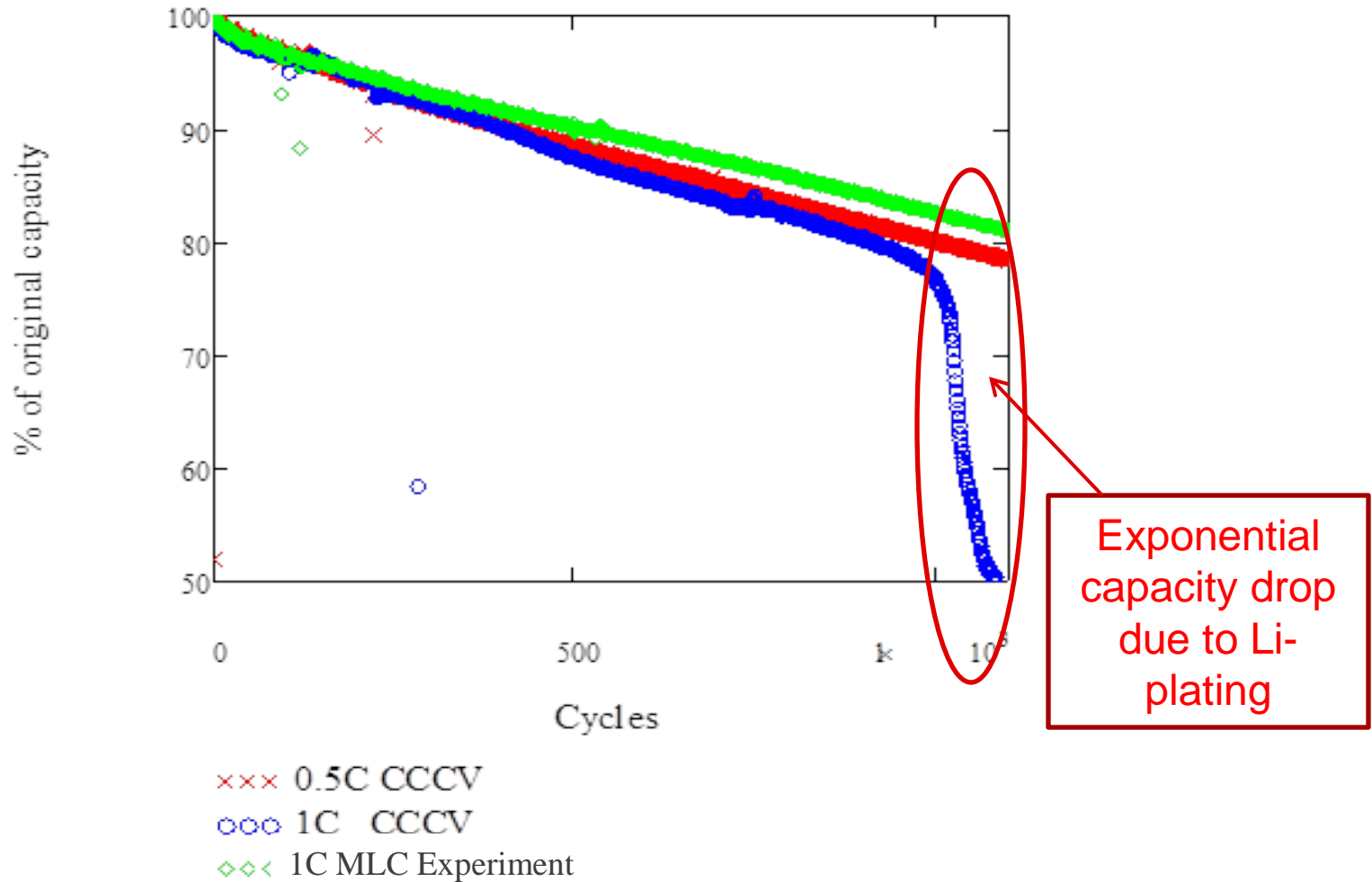

Optimization of Charging Profile for Fastest Possible charge. Degradation reduced compared to CC/CV at same rate

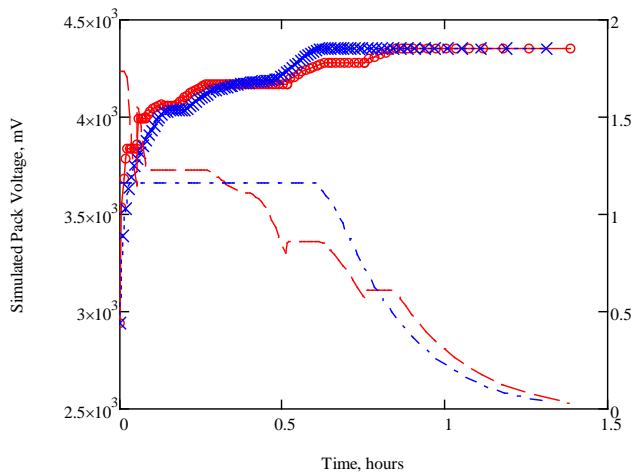

- voltage MLC
- × voltage 1.2C CC/CV
- current MLC
- current 1.2C CC/CV

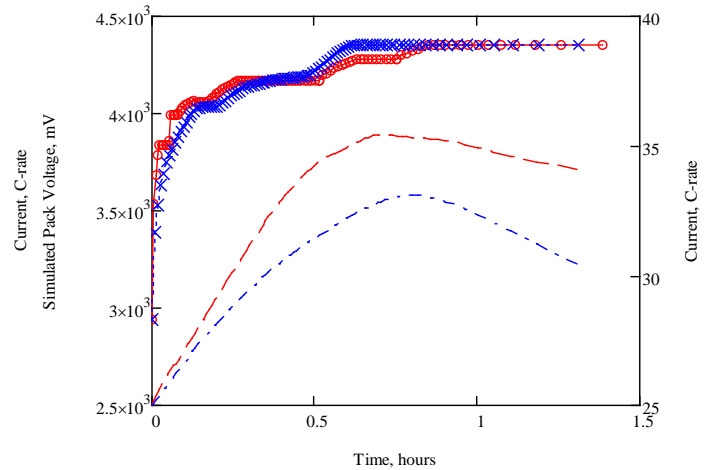

- voltage MLC
- × voltage 1.2C CC/CV
- temperature, MLC
- temperature, 1.2C CC/CV

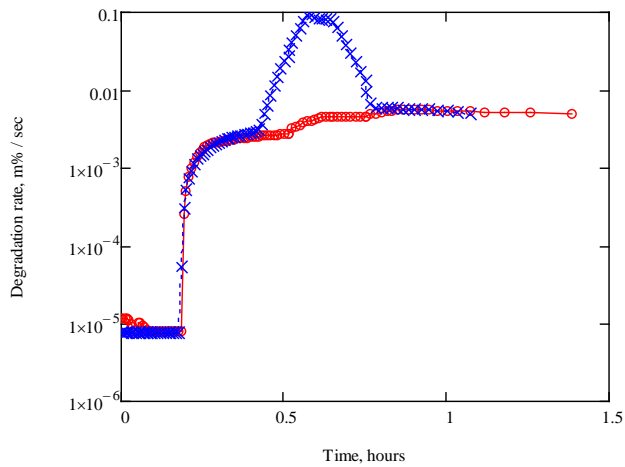

- optimized profile
- × CC/CV 1.2C rate

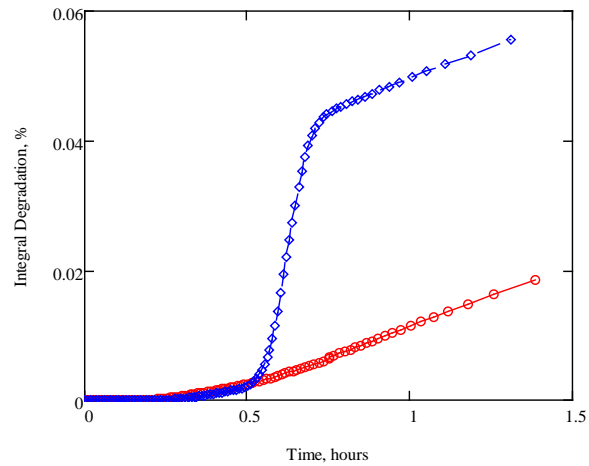

- optimized profile
- ◇ CC/CV 1.2C rate

BMU for Autonomous Charge Control

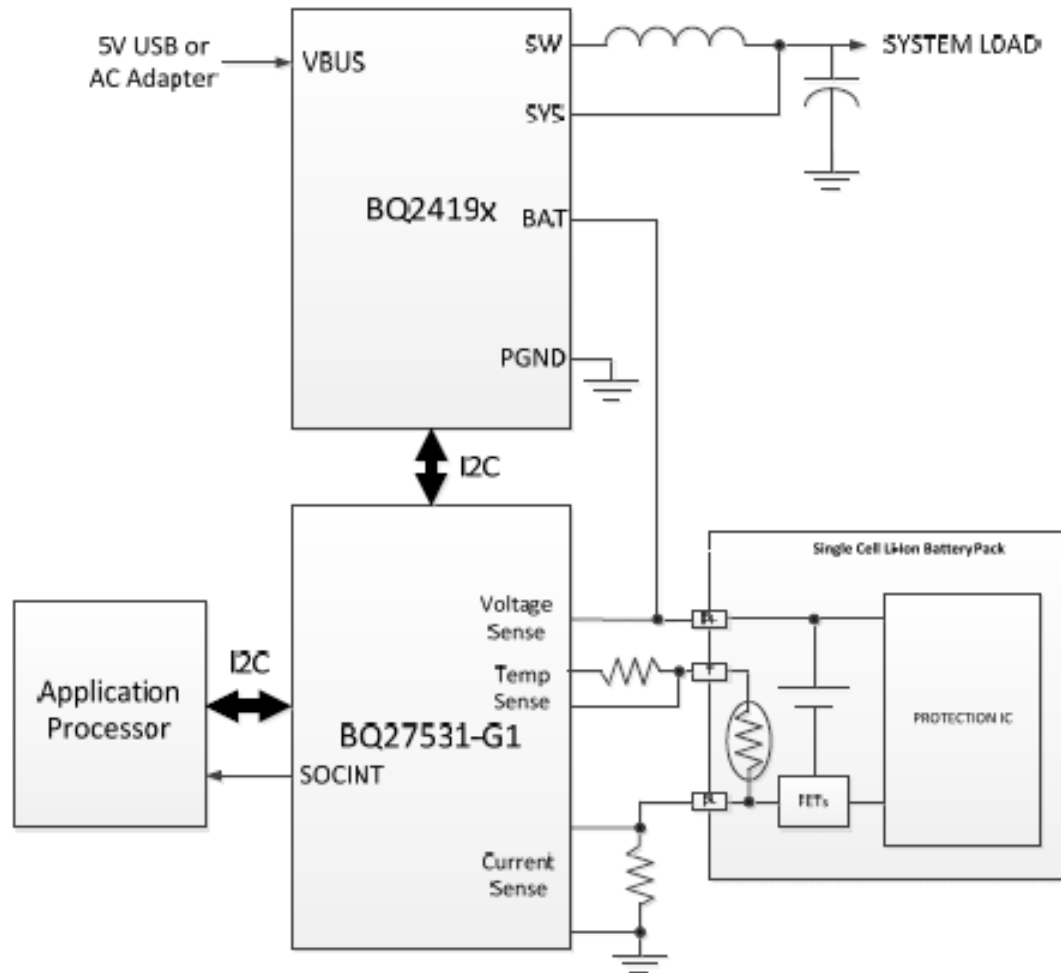

BMU Flexible Solution

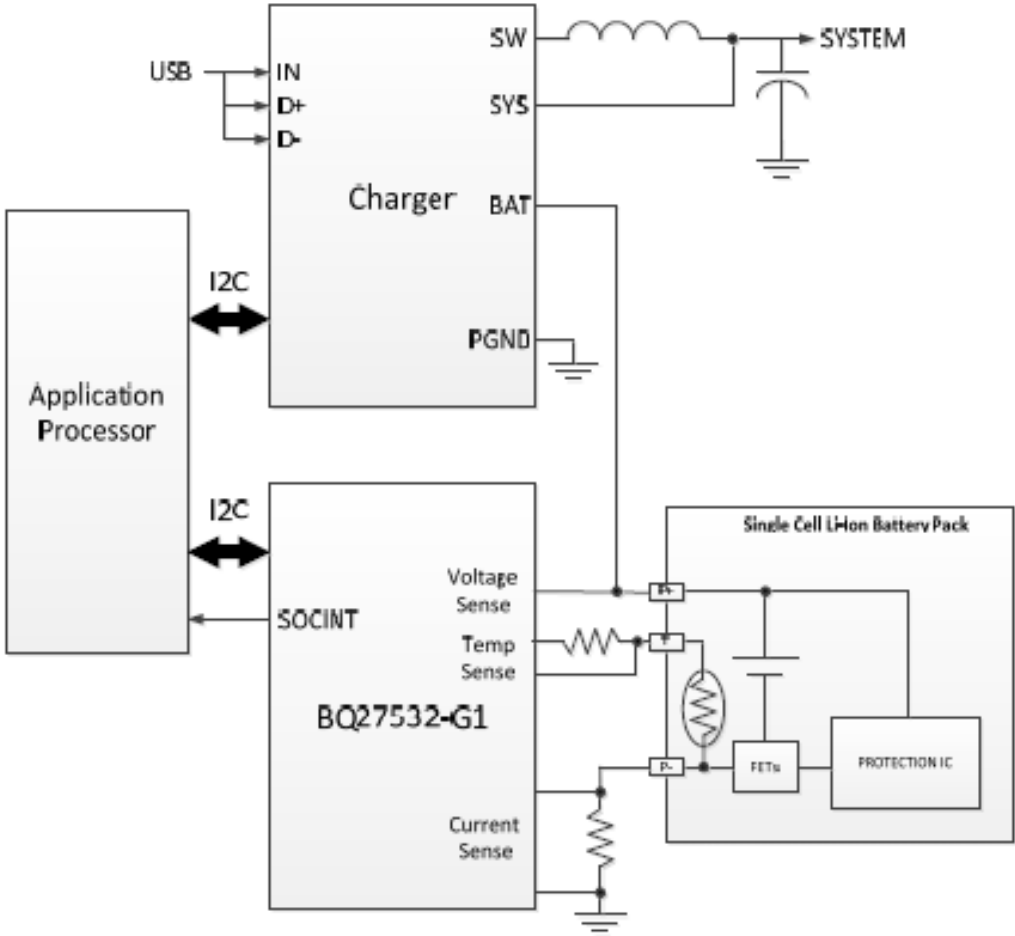

MaxLife applications

- Fast Charging
- Charging in wide temperature range
- Increased longevity beyond 500 cycles
 - Improved user experience with battery remaining functional
 - Avoiding cell swelling
 - Prevent unsafe accumulation of lithium dendrites



Thank You!