



maxim
integrated™

24V+ Power Solutions

March, 2016

JP Ryu (류제필 부장)

The Evolution of Manufacturing

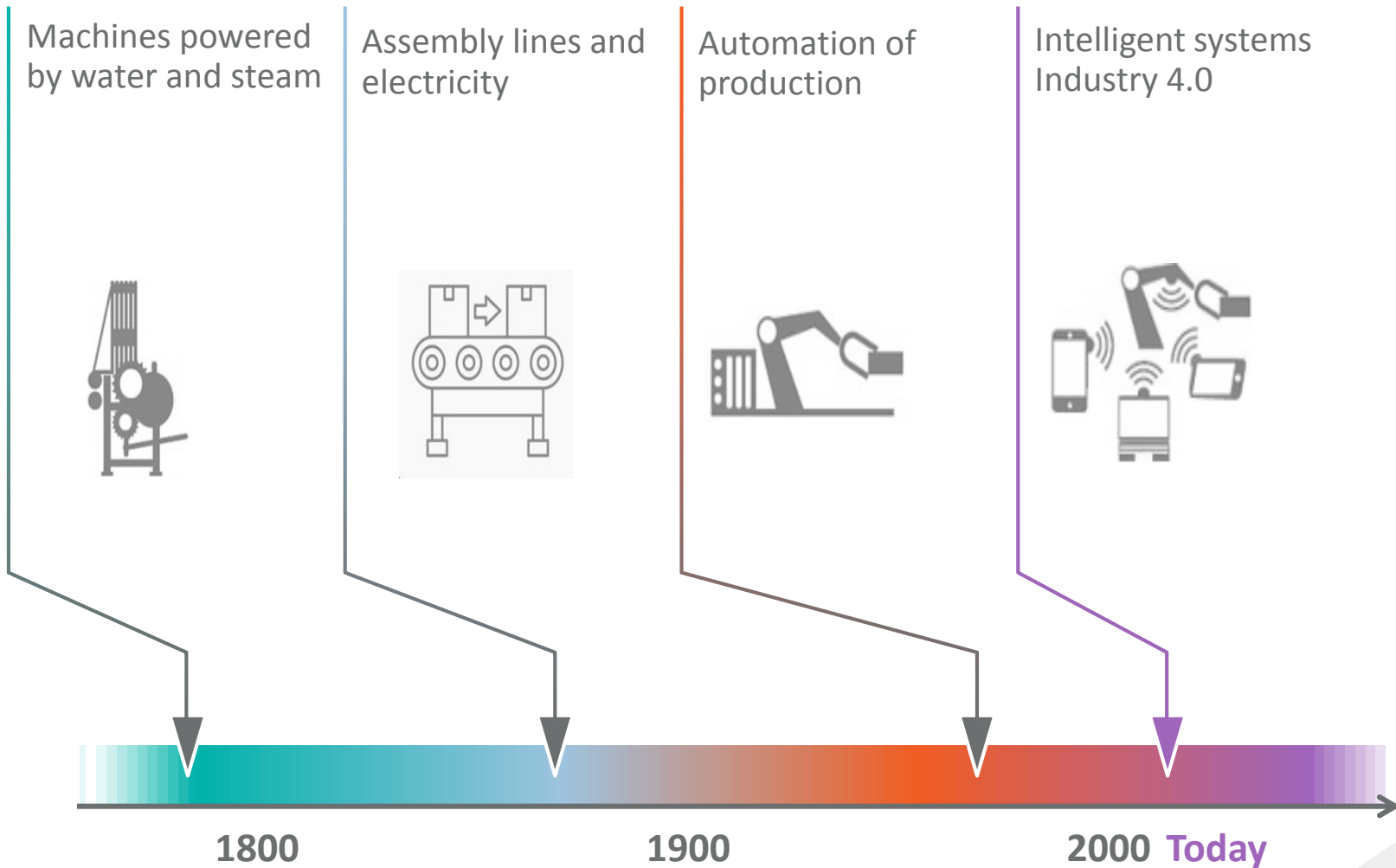

Smarter and Smaller Systems Demand Revolution in Power System Architecture

- Higher Efficiency
- Robust and Reliable
- Small Size
- Ease of Use

Typical High Voltage Applications



Factory Automation



Bldg. Automation & UPS



Distribution Automation

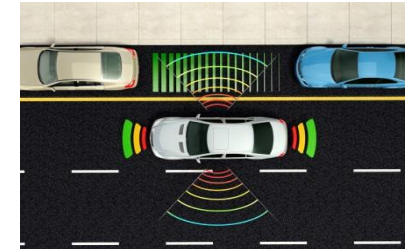

Transport Automation



Security & Surveillance



Power Tools



Networking & Data Center

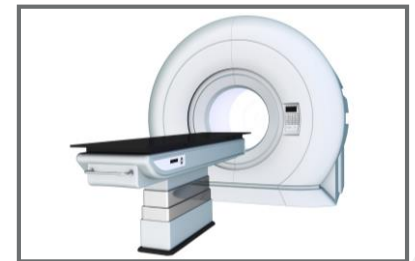

Healthcare

Power System Solution

System Protection

Power Modules

High Voltage Buck/Boost

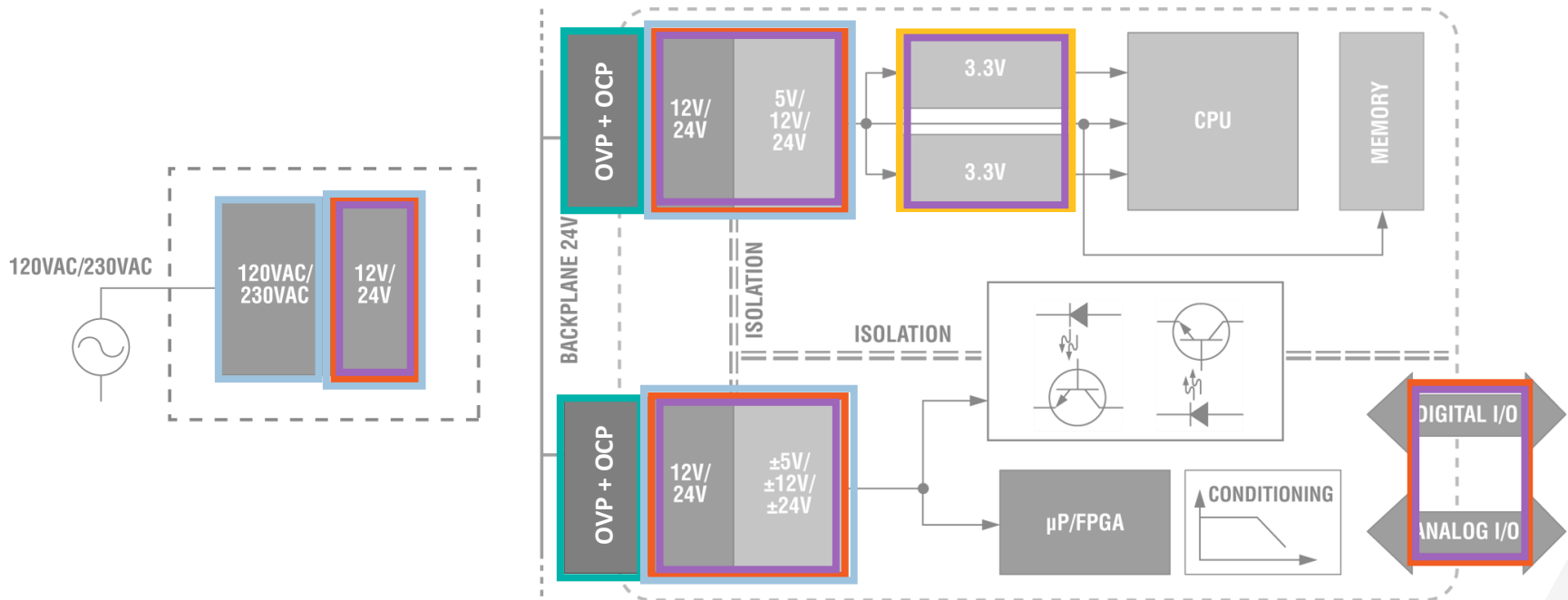

Isolated Controllers

Intermediate rail Bucks/PMICs

Robustness in Harsh Industrial Environments

60V Input and -40 to 125C Operation

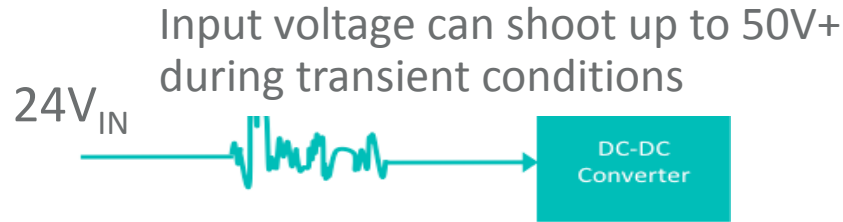

IEC61131-2, IEC60664-1 specifies 60V max DC transients

24V/48V DC

Inductive ringing

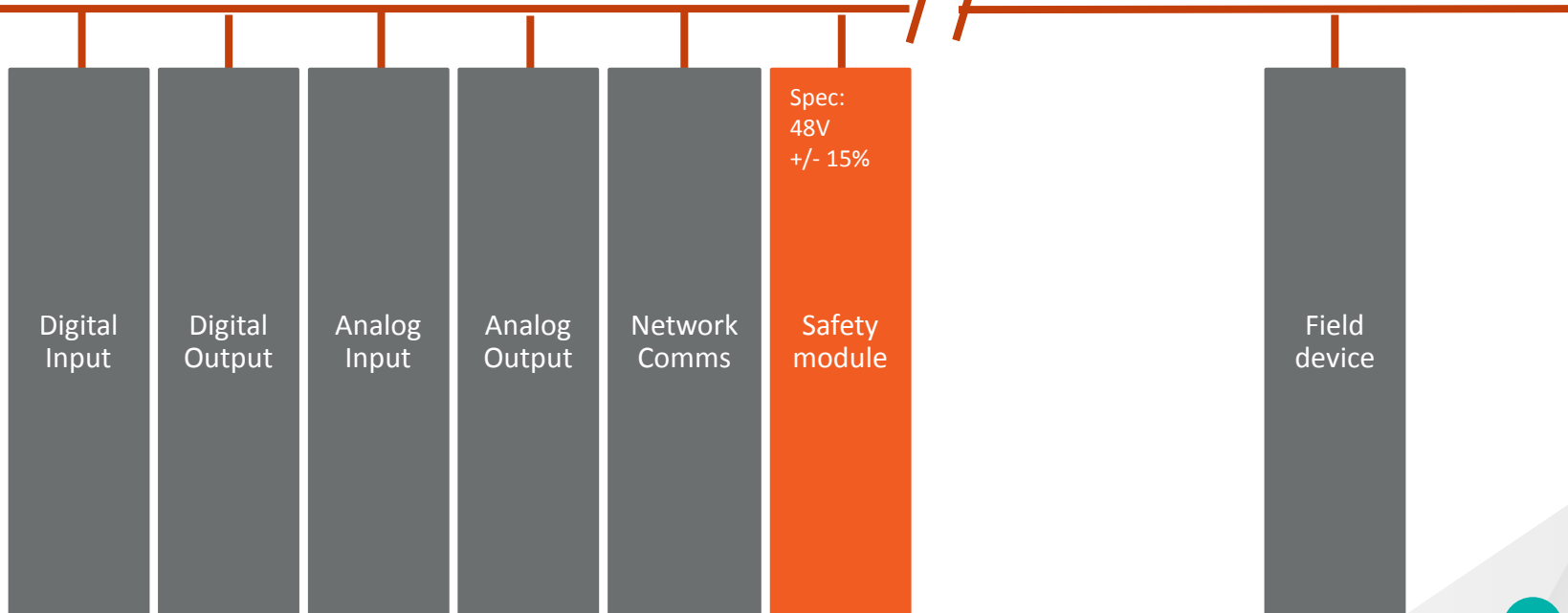

System Protection Requirements

Voltage

- Input De-bounce/Hot plugging
- Input under/over-voltage (UV/OVLO)
- Reverse Input polarity protection
- Surges and Transients(IEC61000-4-4,5)

Current

- Overcurrent/Short circuit protection
- Reverse current protection

Other

- Thermal protection

Maxim Enables Industry Transformation

Power Dissipation, Reliability, Size, Cost, Ease of Use

HV Bucks Synch Rectification

- 50% cooler
- 50% less space
- 75% less BOM count
- Internal FETs, protection & compensation

Modules

- Ease of use
- QFN-like pinout
- P2P in same size
- Shielded inductor

Port Protection

- Integrated FETs
- 50% smaller solution size
- 50% of discrete costs
- More robust

High Efficiency Isolated

- High efficiency active-clamp
- Flyback & Iso Buck
- Eliminate optocouplers

Intermediate Rail

- Typical industrial intermediate rail bucks
- High frequency
- Configurable features
- PMICs

Protection ICs

Positioning Portfolio

Maxim Protection ICs

Industry's most space-efficient & robust integrated protection ICs

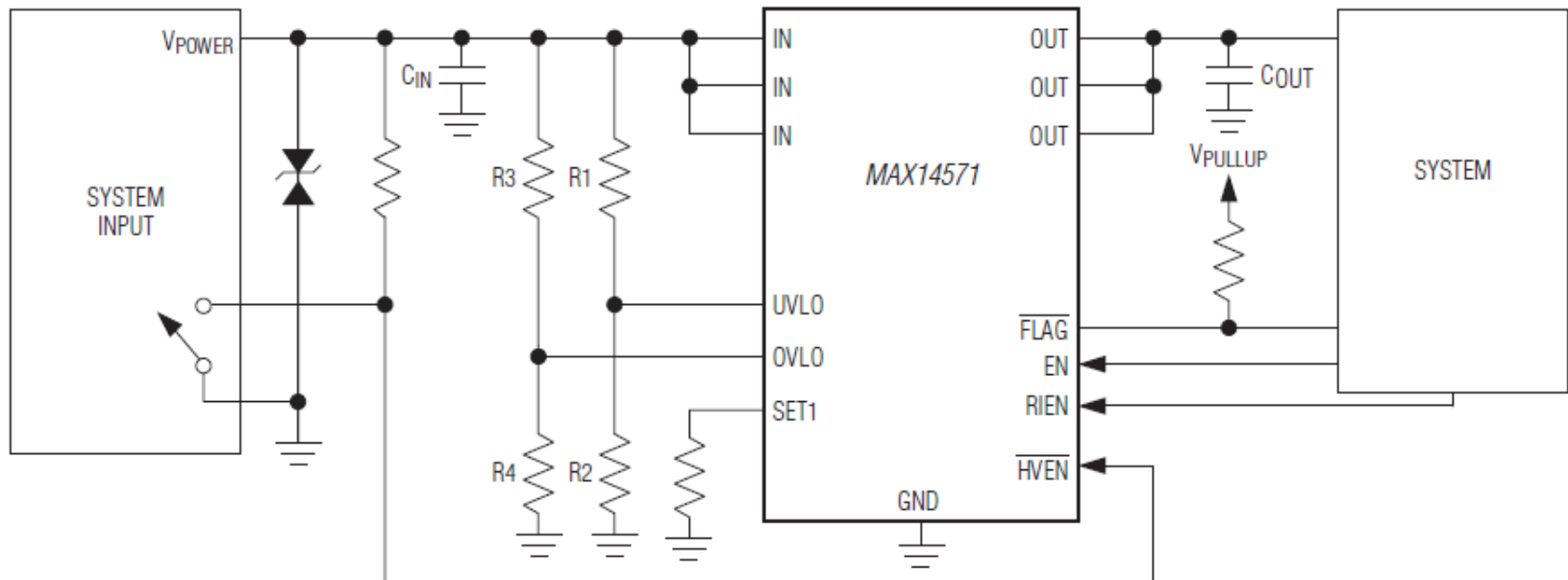

Maxim First to Bring Synchronous Switching to 60V

Buck Regulators Enable Cooler System Operation

EXAMPLE USED: $V_{IN} = 24V$, $V_{OUT} = 5V$, $I_{OUT} = 2.5A @ 500KHz$

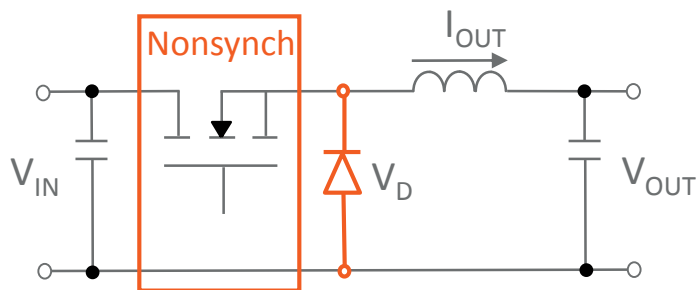

Total solution power loss = 2.3W

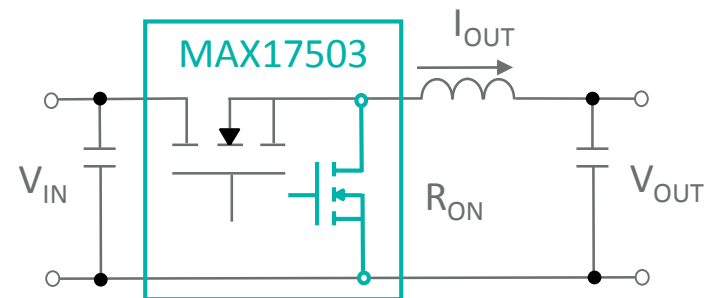
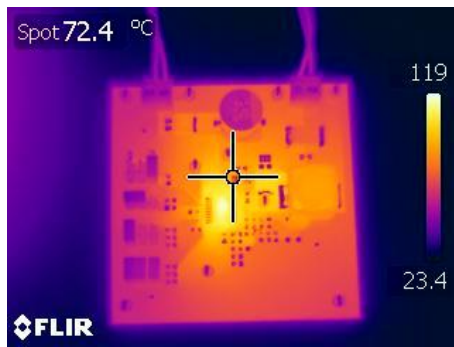

Total solution power loss = 1.1W



MAX15062

92% Peak Efficiency

PWM Mode

Efficiency vs Load Current

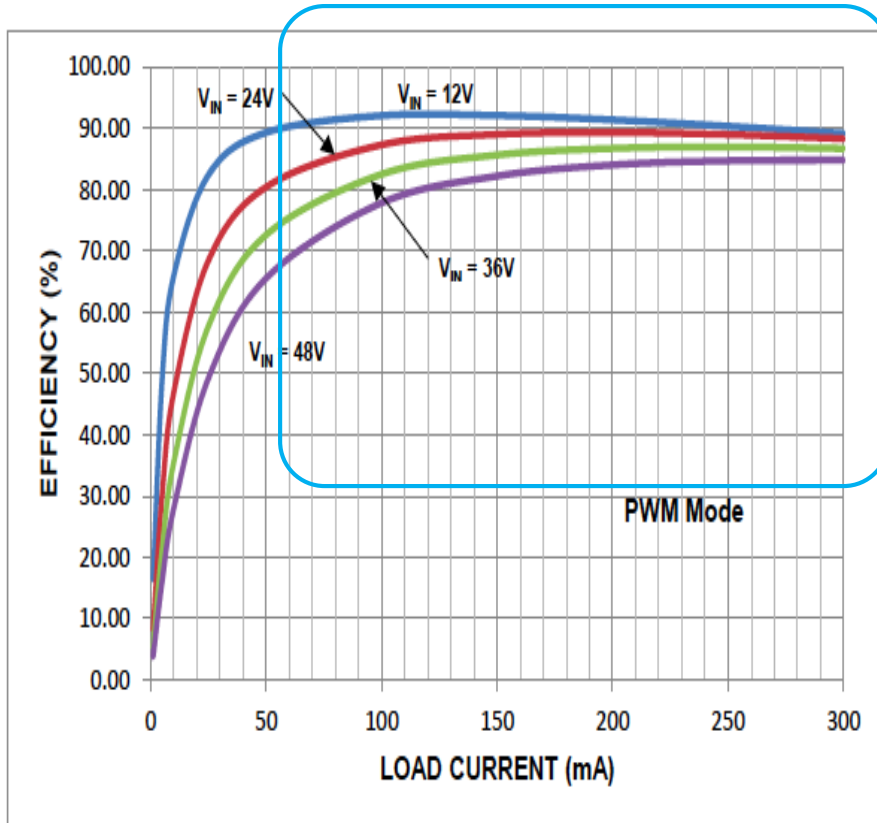

PFM Mode

Efficiency vs Load Current

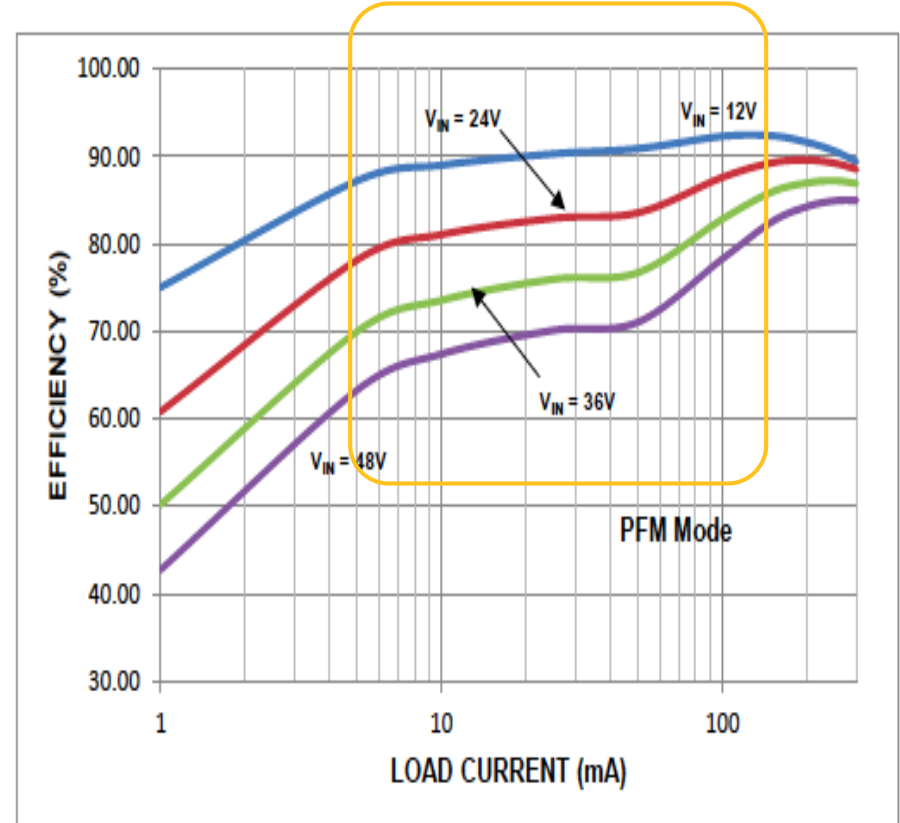

Switching Mode

FULL-LOAD SWITCHING WAVEFORMS
(PWM OR PFM MODE)

MAX15062 toc27

$V_{OUT} = 5V$,
LOAD = 300mA

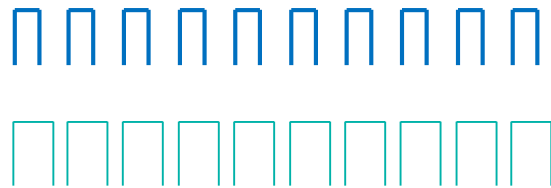
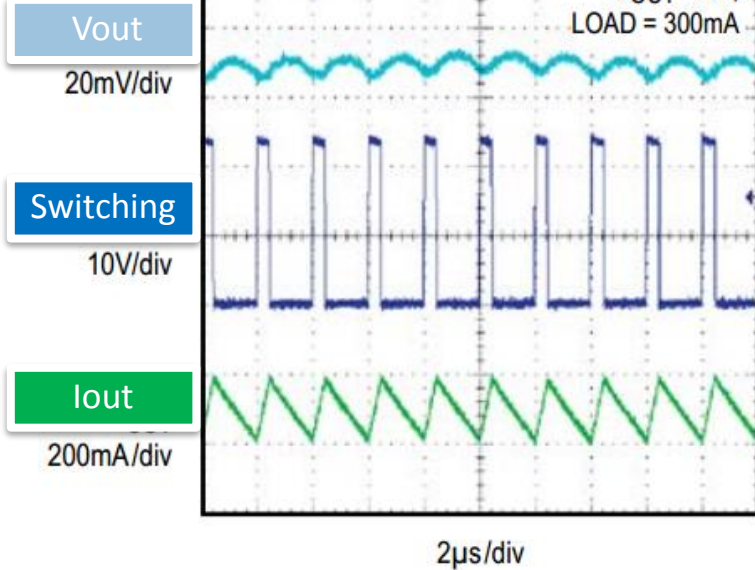

SWITCHING WAVEFORMS
(PFM MODE)

MAX15062 toc26

FIGURE 6 APPLICATION CIRCUIT
 $V_{OUT} = 5V$, LOAD = 20mA

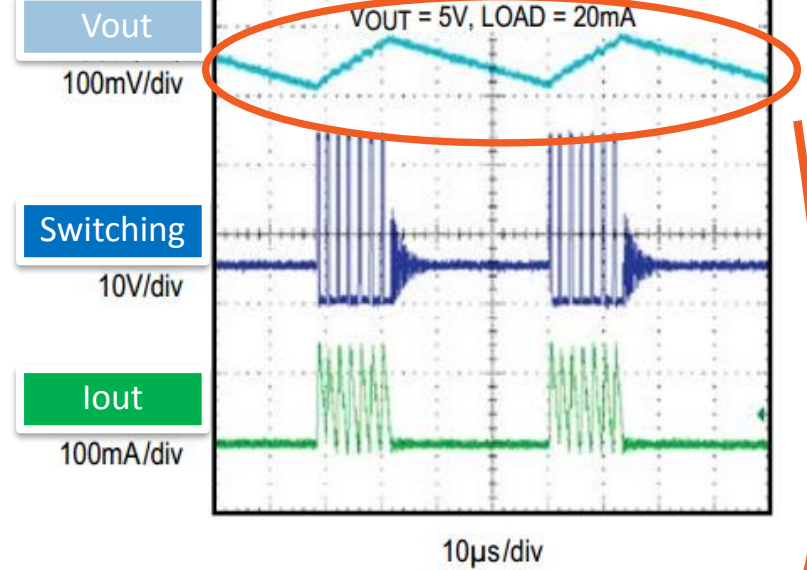

MAX15062 Switching Mode

PWM Mode

PFM Mode

FULL-LOAD SWITCHING WAVEFORMS
(PWM OR PFM MODE)

SWITCHING WAVEFORMS
(PFM MODE)

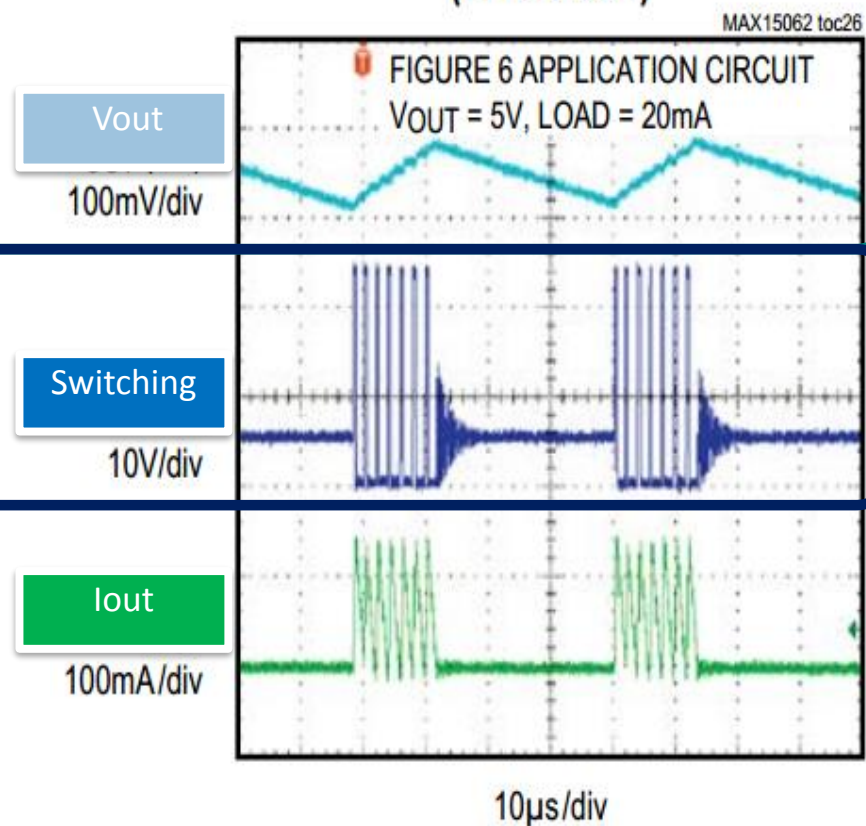
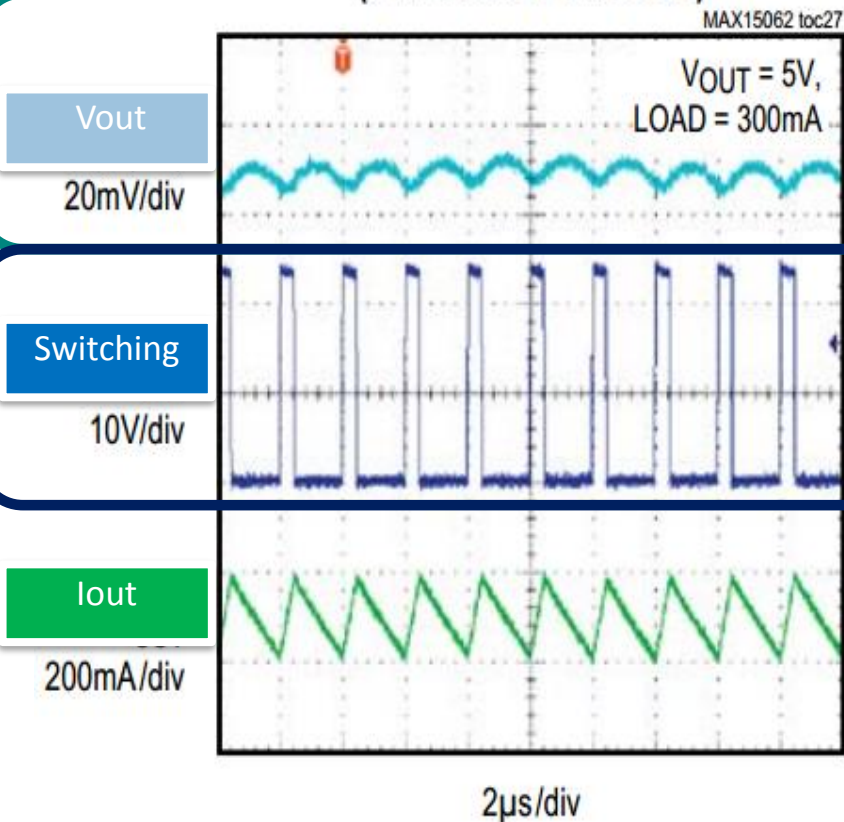

Power Modules: Progressive Integration

Less Integration

More Integration

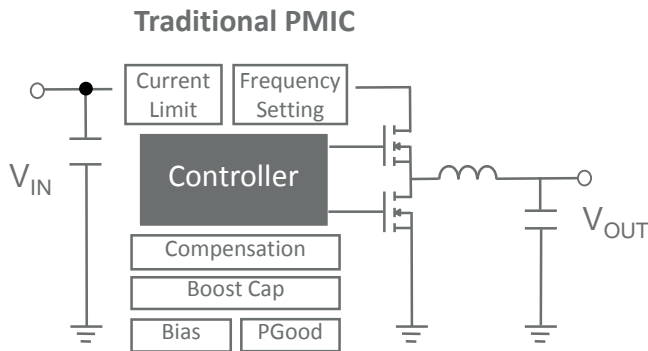

30+ Components

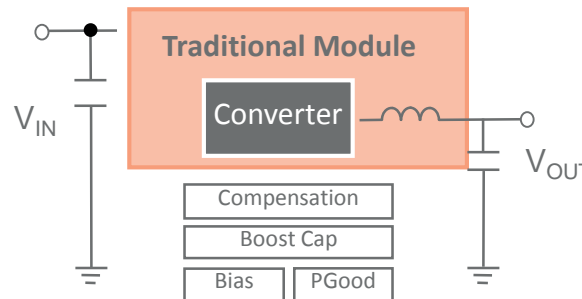

8-10 Components

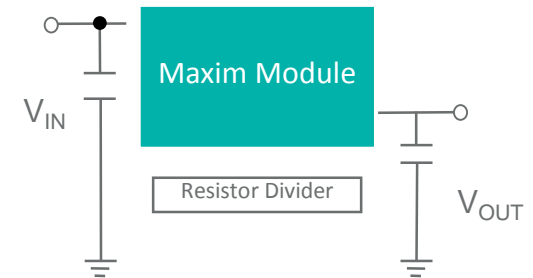

4-5 Components

Integration Without Compromising Flexibility

High Integration = Reliable Protection

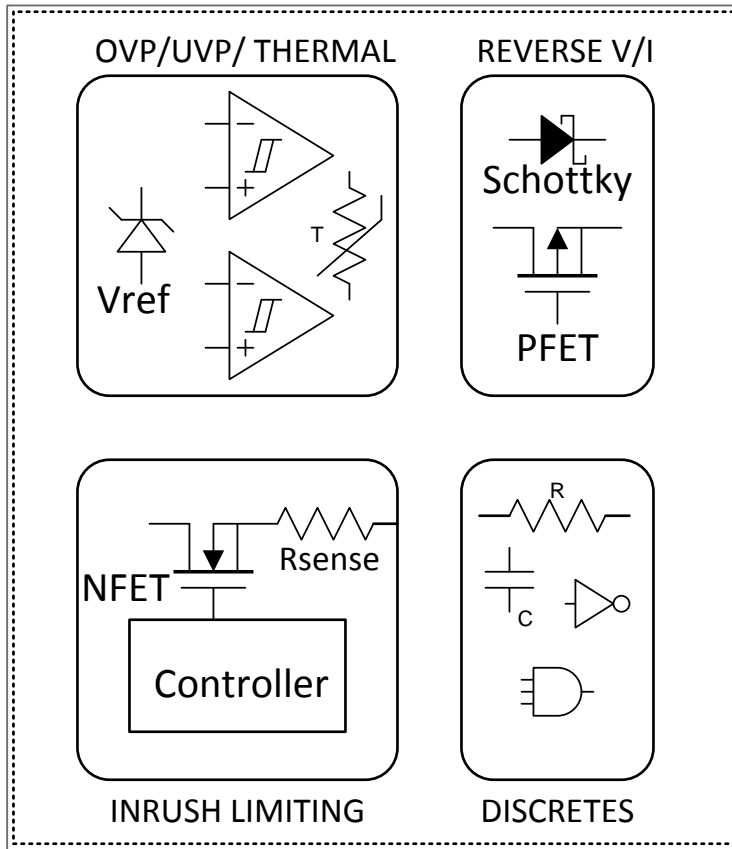

Maxim
Solution

- Smallest Solution Size
- Reduced qualification challenges
- Lower system costs

Power Modules

Technology
Portfolio
Positioning

What is a power module?

Example Power Module:

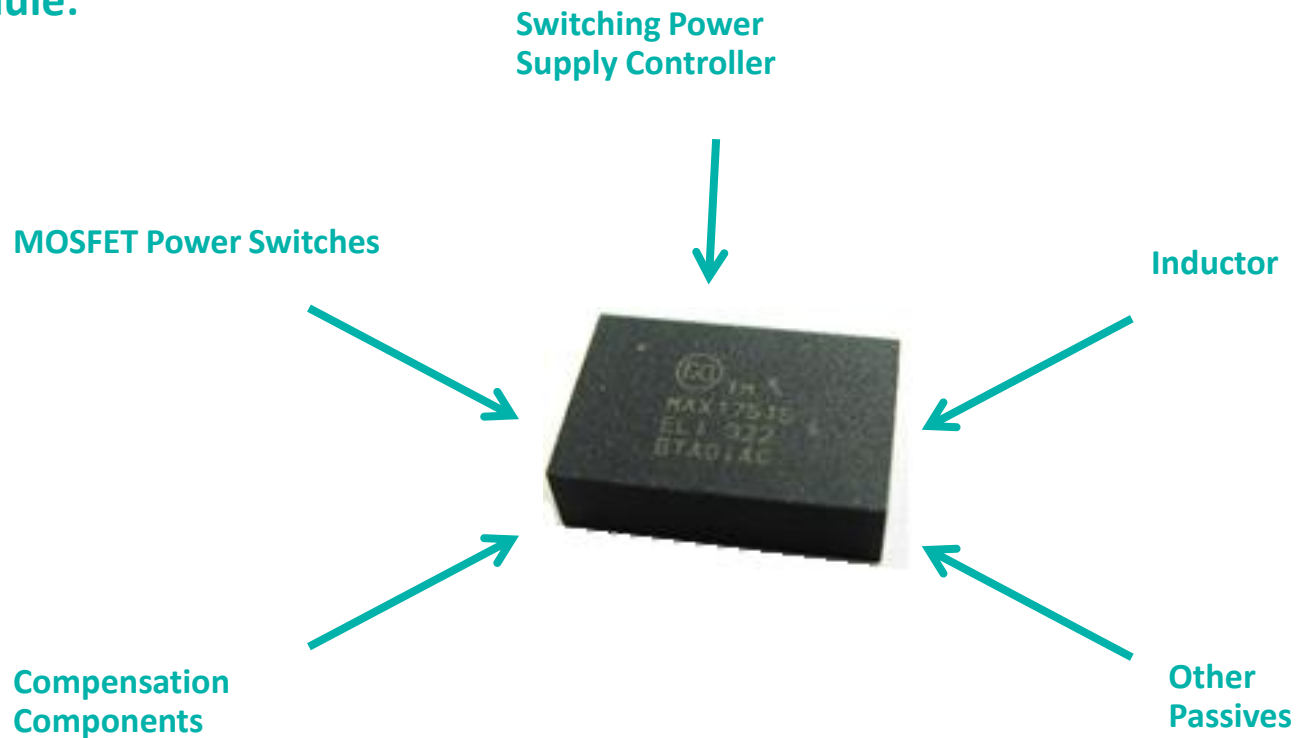

Progressive Integration of Power Solutions

Controller

Regulator

Module

Less Integration

More Integration

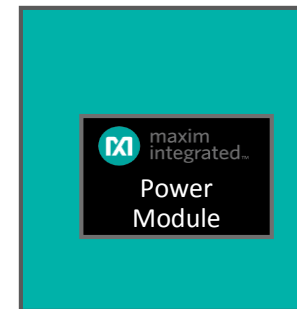
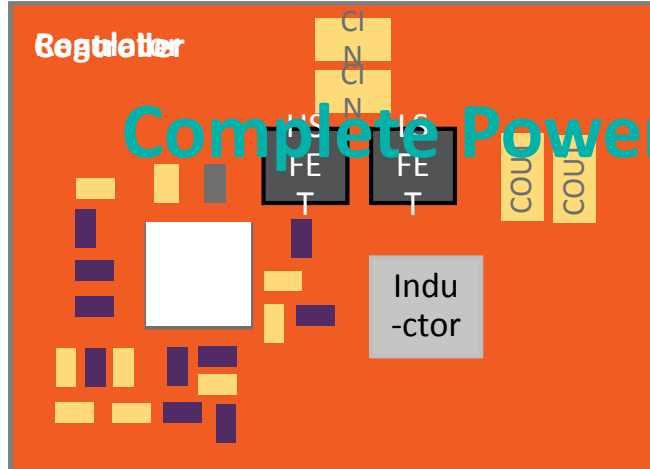

Maxim Himalaya Power Modules

Disrupting the Module Choice For Customers

- ✓ Integrates all power components into module
- ✓ Himalaya technology delivers industry's highest efficiency
- ✓ Enables migration across voltages/currents with pin-to-pin parts
- ✓ Provides cost reduction path from modules to ICs for high volumes

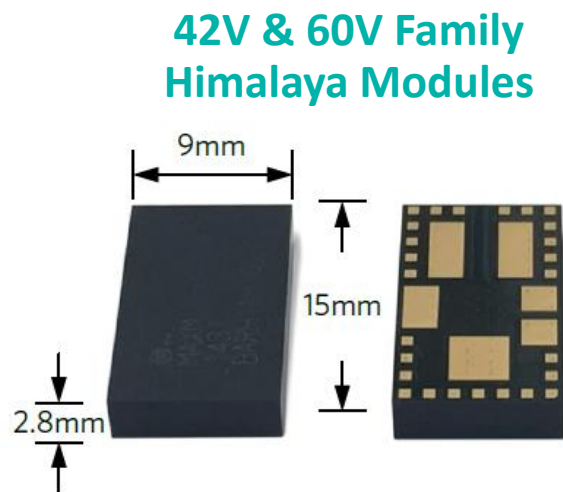
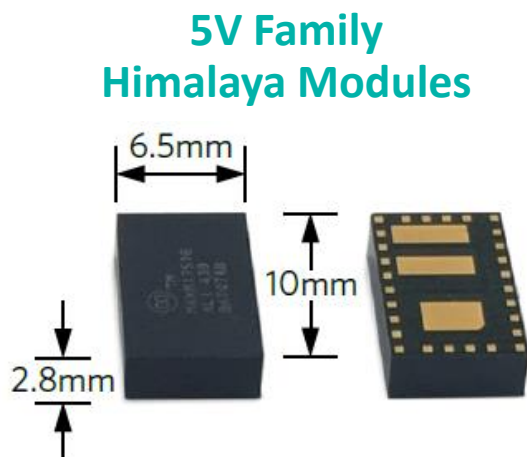

MAXM17504 EVKIT

Input Voltage: 4.5V to 60V
Output Voltage: 0.9V to 12V
Output Current: 3.5A

Minimal external components required

Extremely small solution footprint

User-friendly & customizable

Convenient SiP package with QFN-like pinout

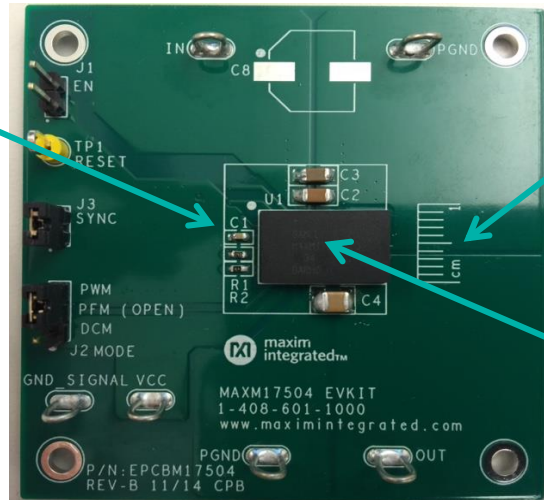

Maxim's New Power Modules

Power with built-in inductors and passives enable a new class of easy-to-use power modules and multi-function ICs

Benefits

- ✓ Ease-of-use
- ✓ Small solution size
- ✓ Minimal external components
- ✓ Reduced design complexity
- ✓ More reliable
- ✓ Faster time to market

Applications

- Test & Measurement
- FPGA & μ P Load
- Control & Automation
- HVAC, Building Control

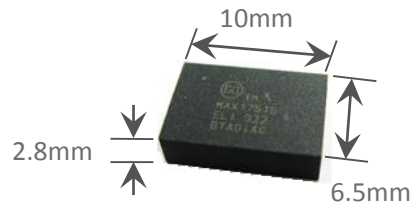

Small Size

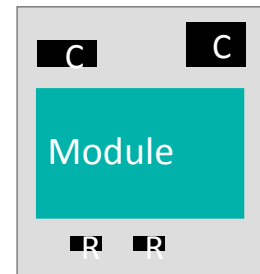

Minimal BOM

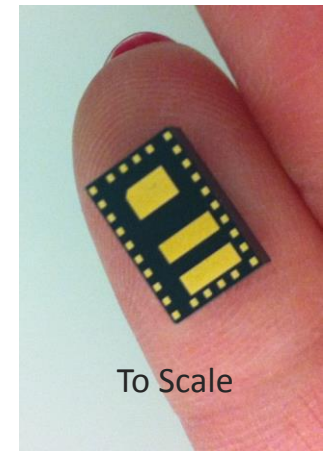

QFN-Like Pinout

Power Module Roadmap

Non-isolated DC-DC Buck Converters

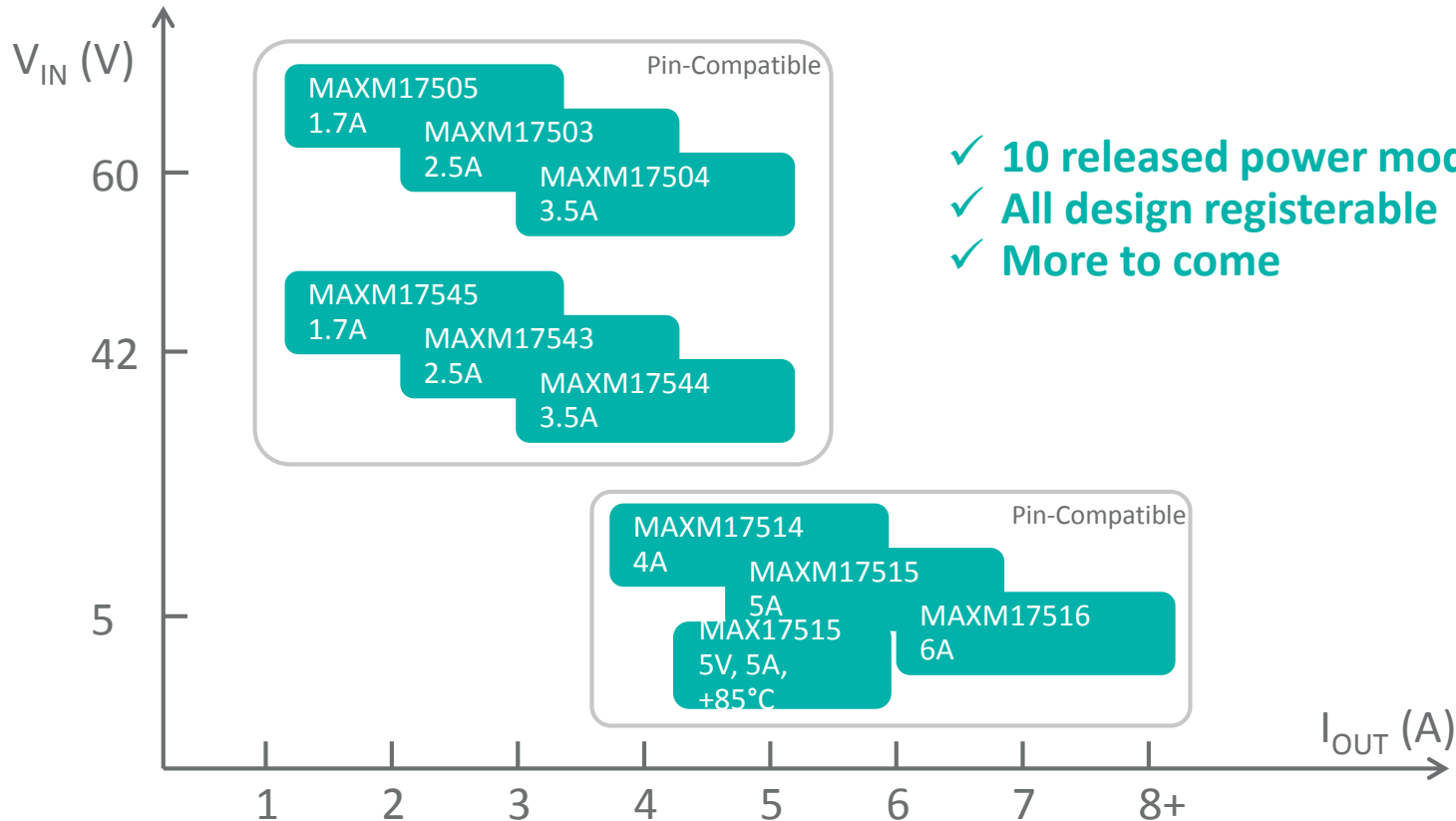

- ✓ 10 released power modules
- ✓ All design registerable
- ✓ More to come

Summary

- New applications are adding smarter functionality in smaller size
- New demands on power
 - > Higher efficiency
 - > Robustness
 - > Small Size
 - > Ease of Use
- Maxim provides innovative solutions for the entire power system
 - > Robust system protection
 - > Highest efficiency isolated DC-DC and buck regulators
 - > Easy to use modules



maxim
integrated™