



Keysight Measurement Forum 2016

Chong Min-Jie

Characterize and Debug Crosstalk Issues with Keysight Crosstalk Analysis App

Characterize and Debug Crosstalk Issues with Keysight Crosstalk Analysis App

Min-Jie Chong

HPS Product Manager & Planner
Oscilloscope & Protocol Division

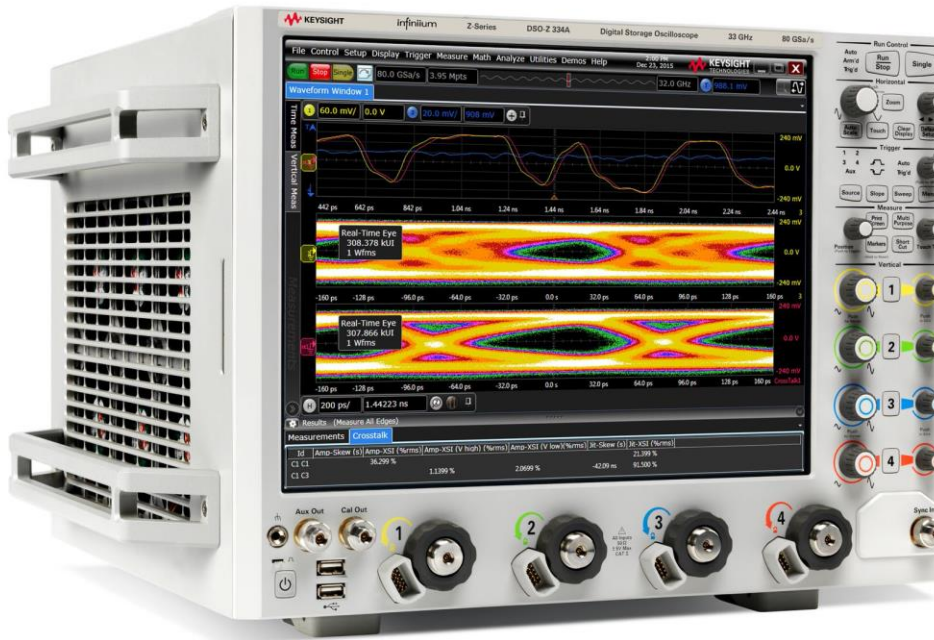

Make important design decisions and recover your crosstalk margins

Agenda

- Crosstalk Overview and Types
- Challenges with Crosstalk Analysis Today
- Overcome Challenges with Keysight Crosstalk Analysis App
- Analyze and Remove Crosstalk
- Theory of Operation
- Summary

Agenda

- **Crosstalk Overview and Types**
- Challenges with Crosstalk Analysis Today
- Overcome Challenges with Keysight Crosstalk Analysis App
- Analyze and Remove Crosstalk
- Theory of Operation
- Summary

Crosstalk Overview

Amplitude interference uncorrelated with data pattern.

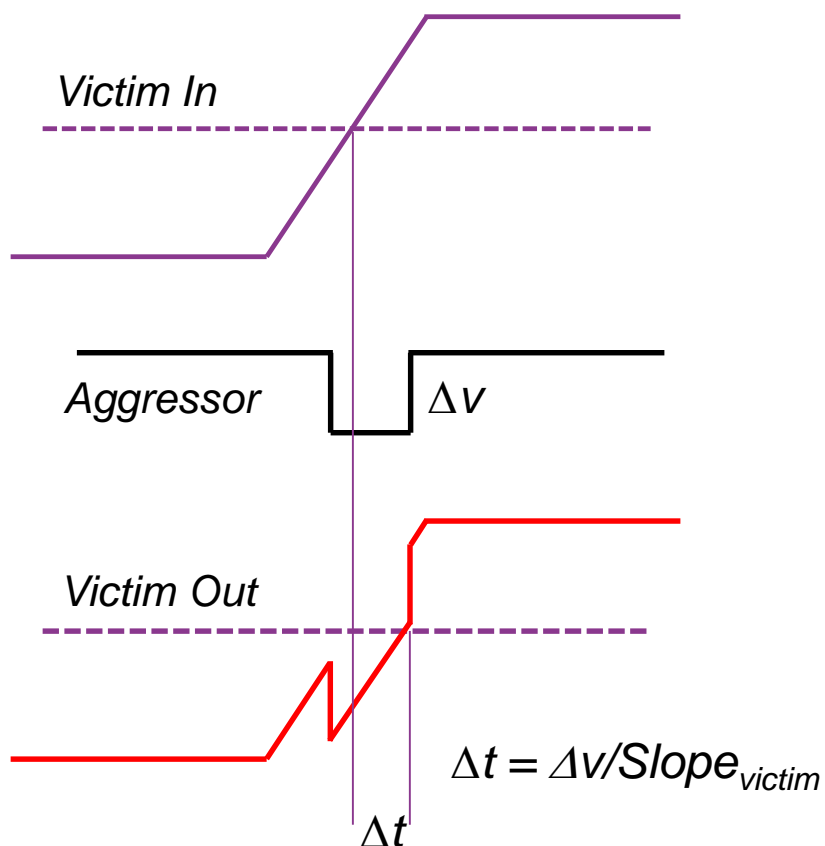

Impact on Eye

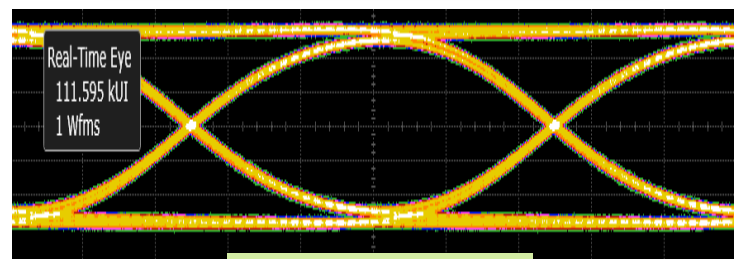

No crosstalk

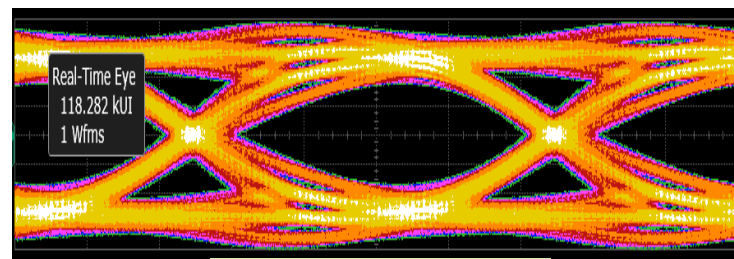

With crosstalk

Transmission Line Crosstalk

- Crosstalk is becoming a more important issue, as data speeds increase, and more lanes are packed into small spaces. For example:
 - 100G standards with 4 parallel 25 Gb/s lines
 - ASICs with 100's of SerDes
- Transmission line crosstalk is the result of electromagnetic interference between electrical components.
- Mainly caused by capacitive or inductive coupling between multiple signal lines.
- Two prominent types:
 - Far End Xtalk (FEXT)
 - Near End XTalk (NEXT)

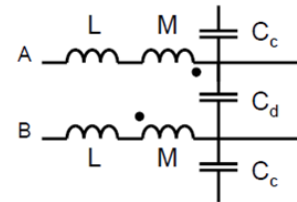

Mutual Inductance and Capacitance between 2 transmission lines.

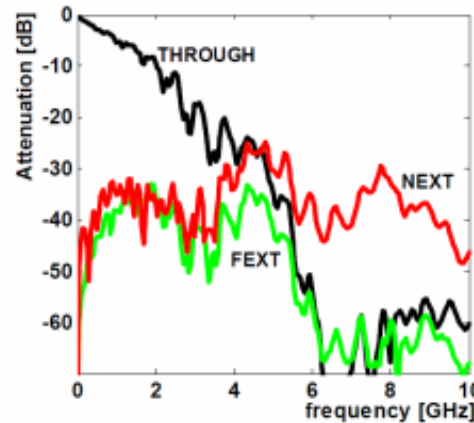
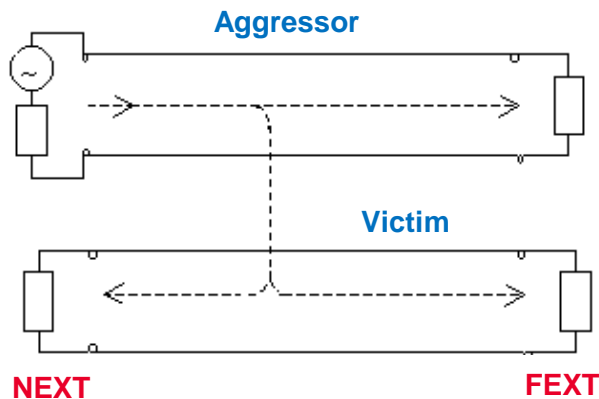

Transfer function examples for insertion loss, NEXT and FEXT

Far-End Crosstalk (FEXT)



No Serial Aggressor



FEXT Serial Aggressor

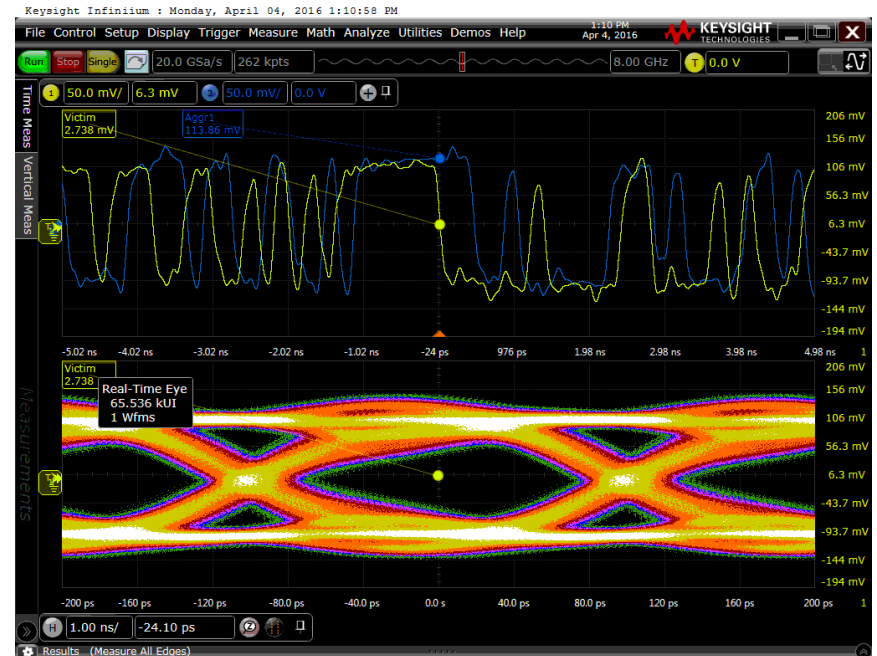

Data rate and pattern of the aggressor and victim are the same, the eye diagram of the victim will show a bulging indicative of FEXT.

Near End Crosstalk (NEXT)



No Serial Aggressor



NEXT Serial Aggressor

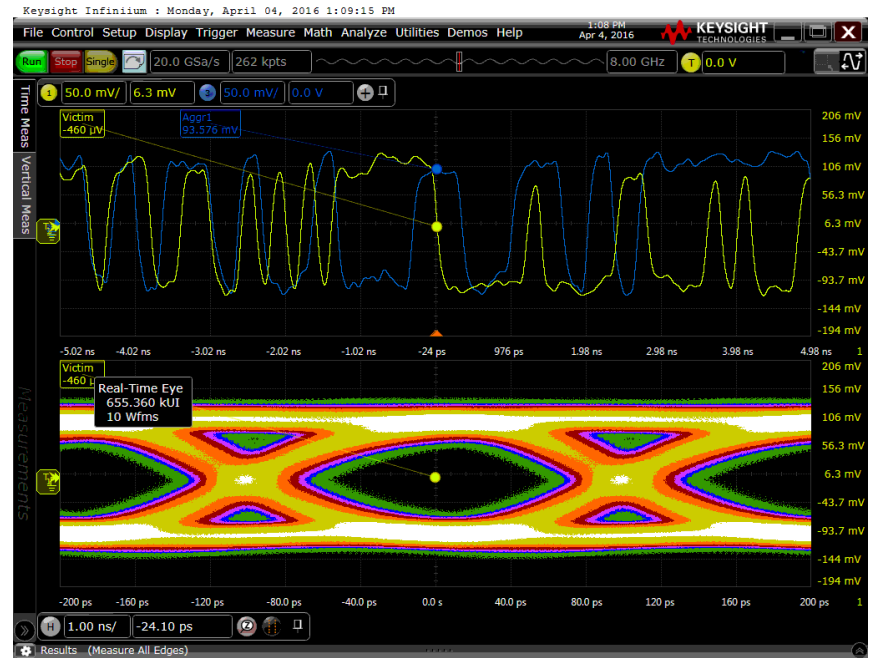

Power Supply Aggressor – PSIJ

Power Supply Induced Jitter

No Power Aggressor



With PSIJ Aggressor

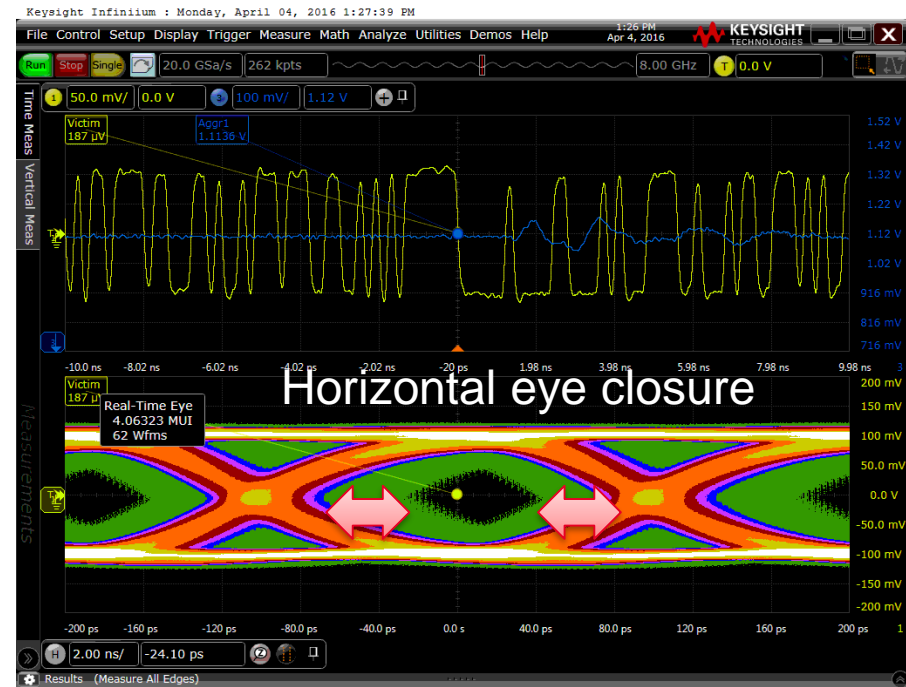

High frequency noise in the power supply, induces horizontal jitter.

Power Supply Aggressor – VDAN

Voltage Dependent Amplitude Noise

No Power Aggressor

With Power VDAN Aggressor

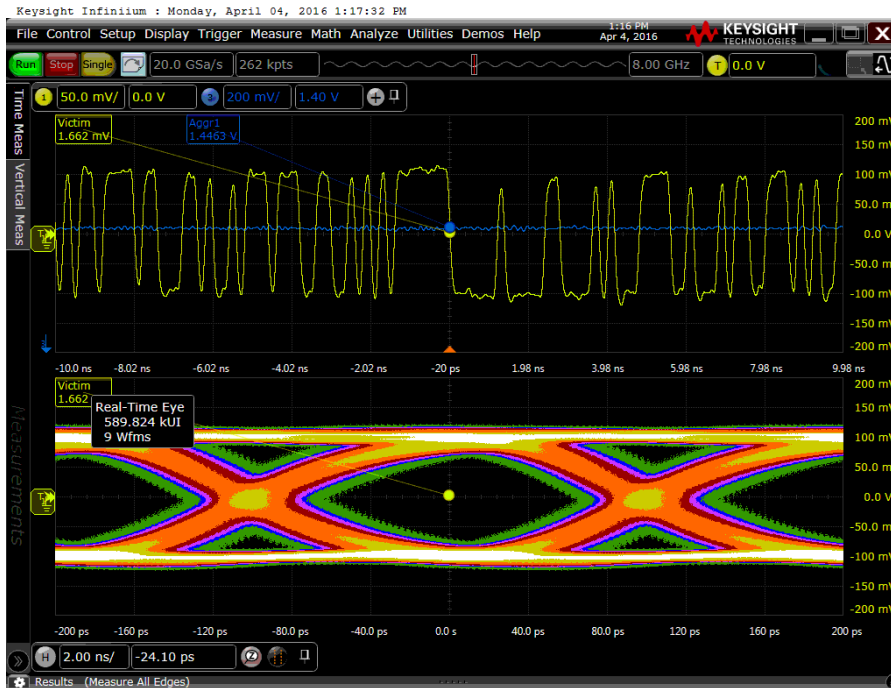

Noise on V_{CC} is transferred to logic high bits, but not affecting the logic low bits, which are tied to ground.

Power Supply Victim

- A power supply can also be a victim, where the serial data lines are the aggressors. The best example is Simultaneous Switching Noise (SSN) which can create Ground Bounce (the high voltage rail can also “bounce” and may be referred to as V_{CC} sag).
- SSN is the result of parasitic inductances that lie between the device (chip) ground and the system (board) ground. When a serial data line switches states, current flows through these inductances which produces a voltage drop. The more lines that switch at the same time (simultaneously) the bigger the drop.

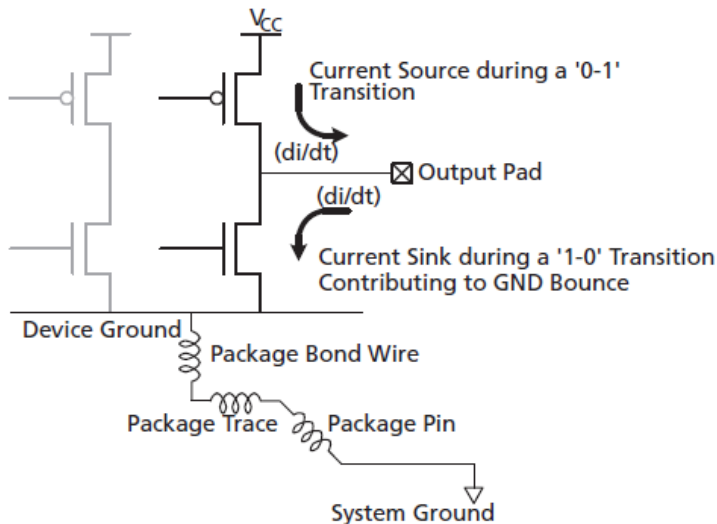

A simplified circuit showing the parasitic inductances that contribute to ground bounce

Power Supply Victim

Example of power supply victim due to clock edges

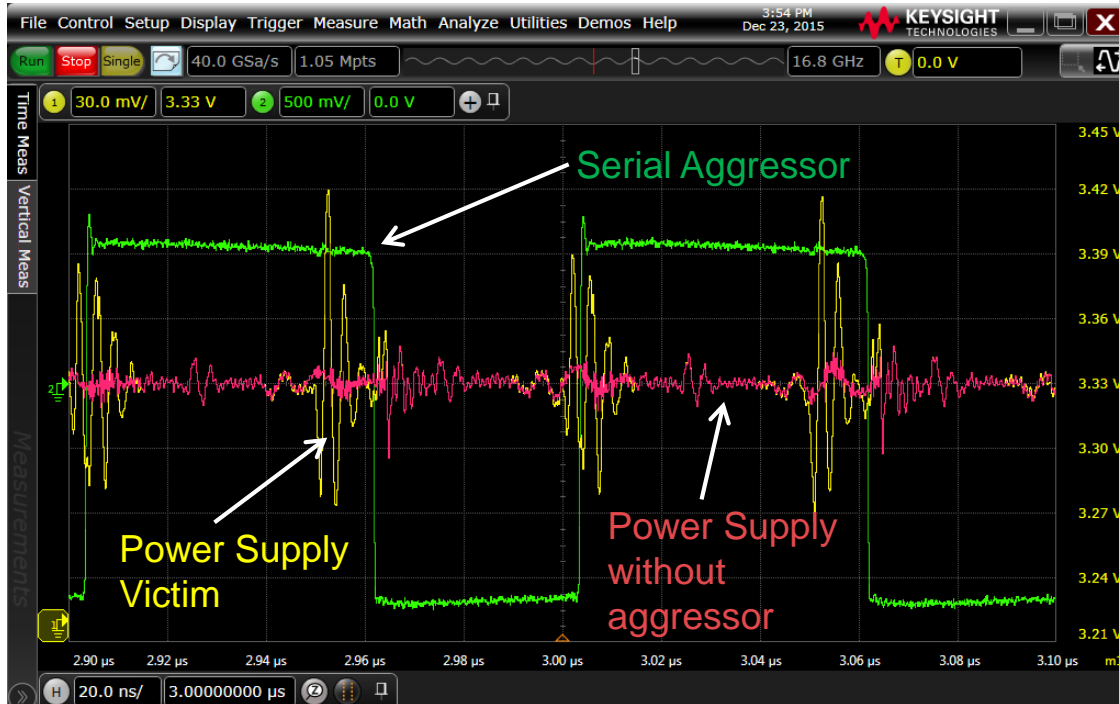

Note the large ringing in the yellow power supply that is correlated with the edges of the clock.

Agenda

- Crosstalk Overview and Types
- **Challenges with Crosstalk Analysis Today**
- Overcome Challenges with Keysight Crosstalk Analysis App
- Analyze and Remove Crosstalk
- Theory of Operation
- Summary

Legacy Method of Measuring Crosstalk

- The need to troubleshoot and characterize crosstalk is not new, but the legacy methods of measuring crosstalk in digital communications systems has relied on the process of selectively disabling some channels while enabling others.
- This necessarily requires measuring the crosstalk effects in the system while operating in special test modes, which means measuring them under abnormal conditions. Worse yet, some systems cannot even operate the necessary special modes.

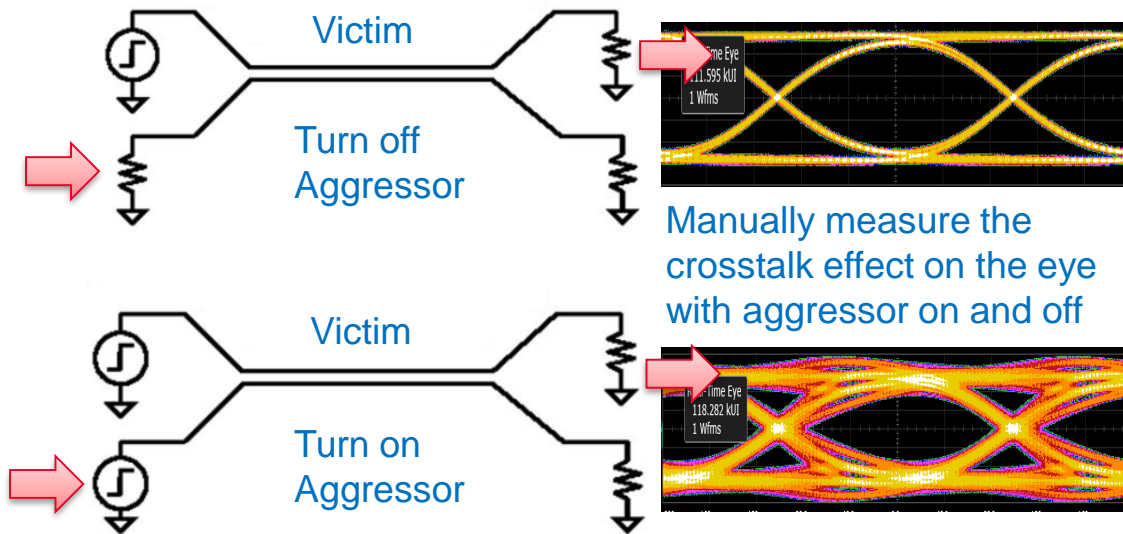

Challenges:

- No special test modes to turn on and off aggressors
- Huge effort and time to characterize crosstalk from multiple serial aggressors.
- Power supply cannot be turned off.

Crosstalk Simulation, but not Identification or Removal

- VNA can be used to characterize crosstalk between serial data lines. S-parameter models are generated by the VNA.
- Scope and software tools are available today, using the S-parameter models to simulate the waveform distortion, eye closure and jitter performance.

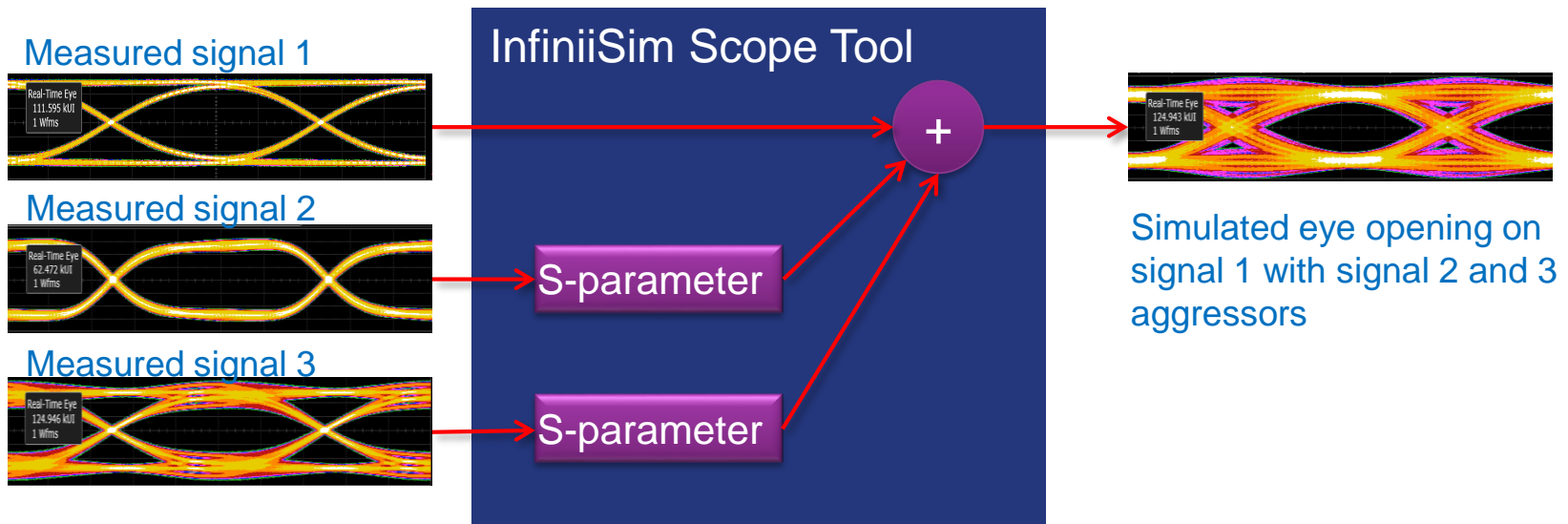

- However, the tools are limited only to simulation, but unable to identify source of crosstalk on the real system or remove crosstalk from the measured waveforms for analysis to see how much margin can be recovered.

Power Supply, Non-Linear Crosstalk

- For serial data lines, VNA can be used to characterize the crosstalk because they are linear network model.
- However, the **influence of power supply noise** to serial data jitter and amplitude distortion is **non-linear** and no easy way to characterize the crosstalk transfer.

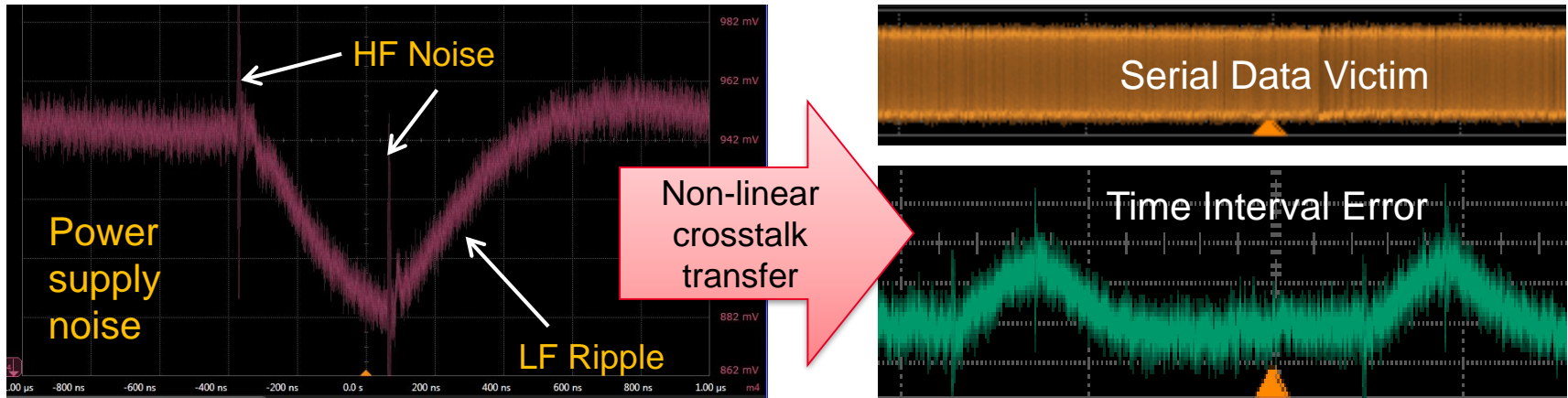

Power supply noise creates a non-linear transfer on the serial data timing error. The crosstalk transfer is difficult to solve and correlate.

Inaccessible Aggressor Signals

- Crosstalk could happen inside a package with accessibility only to the serial data output.
- Is there a way to characterize or debug such scenario?

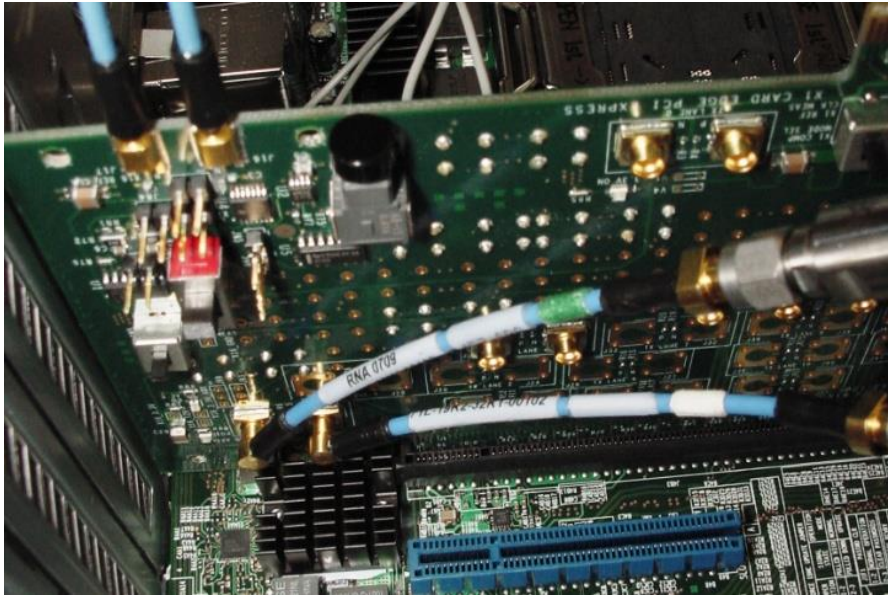

Many crosstalk issues happen inside the package. How to troubleshoot crosstalk when the aggressors are inaccessible?

Agenda

- Crosstalk Overview and Types
- Challenges with Crosstalk Analysis Today
- **Overcome Challenges with Keysight Crosstalk Analysis App**
- Analyze and Remove Crosstalk
- Theory of Operation
- Summary

Crosstalk Analysis Challenges Solved by Application

- Crosstalk Identification
 - Which signals are coupling onto your victim?
- Crosstalk Quantification
 - How much error does each aggressor add to your victim?
- Crosstalk Removal for Analysis
 - What would your signal look without crosstalk?
 - How much margin can be recovered on your signal without crosstalk?
 - If the signal was failing spec, can it pass without crosstalk?

Assist in making important design decisions:

- ***Is it worth reducing crosstalk impact in design?***
- ***Where to improve?***

Features of the Crosstalk Analysis Application

1. Analyze up to four signals (aggressors or victims) at once
2. No crosstalk model or simulation files required
3. Identify aggressors by probing around
4. Report the amount of crosstalk present on victims
5. Work for both NEXT and FEXT, automatically determined by the app
6. Work for power supply analysis
7. Plot waveform without crosstalk on the scope which can be:
 - Used by SDA, EZJIT Complete, InfiniiSim, Equalization and Mask test
 - Saved as a waveform file

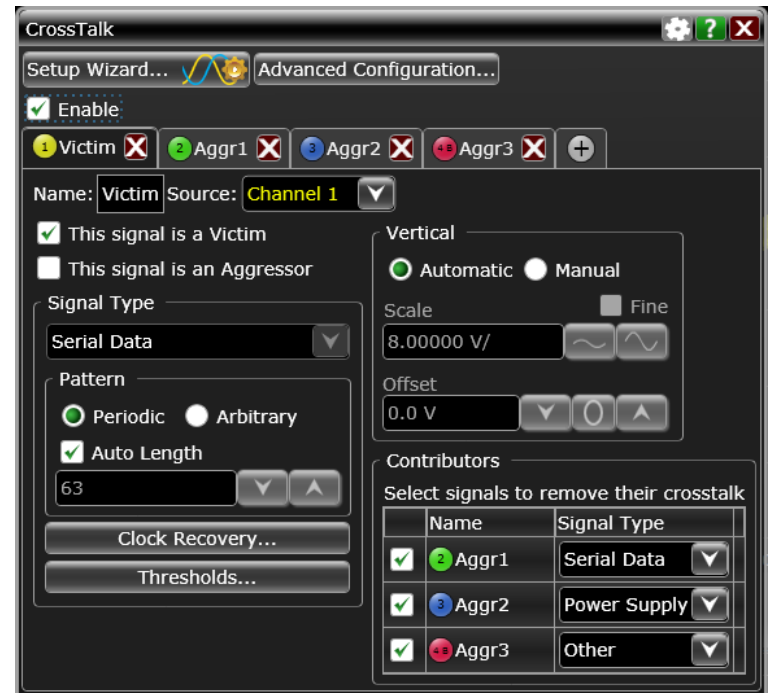

Overcome Inaccessible Aggressor Signals

- The crosstalk application can remove the ideal, ISI and return a waveform with “Unknown XT + Noise” (residual).
- Perform further analysis on this residual waveform with measurements such as FFT, markers, etc. to root cause the source of aggressor.

Remove: Ideal + ISI of Victim

Show: Only Unknown XT + Noise

Contributors		
Select signals to remove their contributions		
	Name	Signal Type
<input checked="" type="checkbox"/>	ⓘ Ideal Victim Wfm	Serial Data
<input checked="" type="checkbox"/>	ⓘ ISI of Victim	Serial Data
<input type="checkbox"/>	ⓘ Unknown XT + Noise	Serial Data

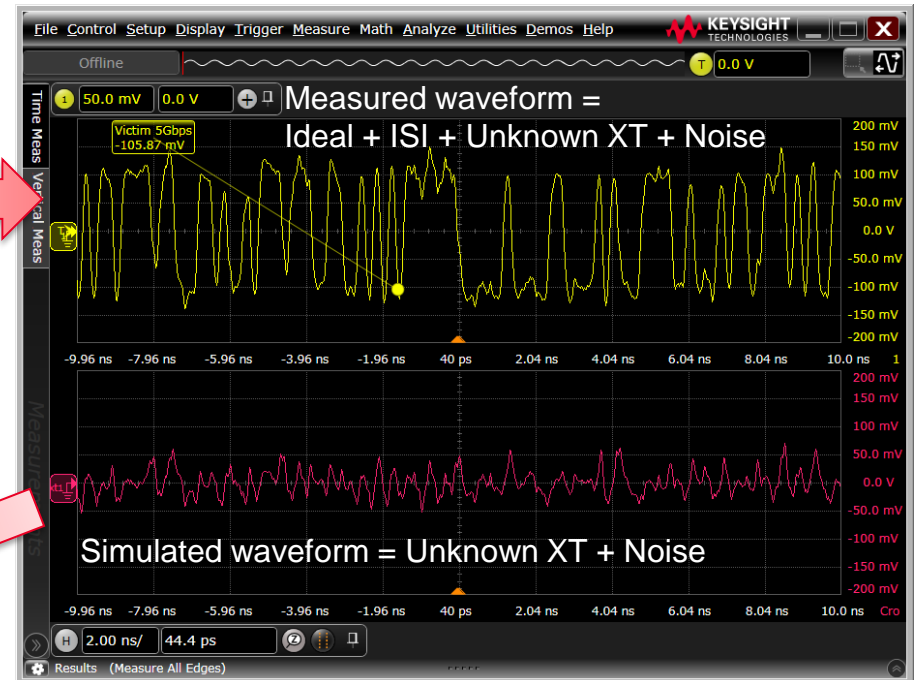

FFT on Unknown XT + Noise

Crosstalk Analysis Setup

1. Probe up to 4 signals (Aggressors or victims).
No simulation models or inputs are required.

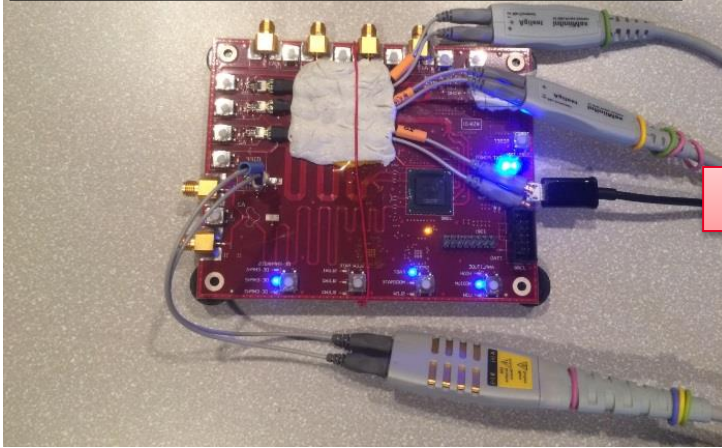

2. Setup the victim signal.

4. The app reports the amount of crosstalk from each aggressors and return a waveform without crosstalk for analysis.

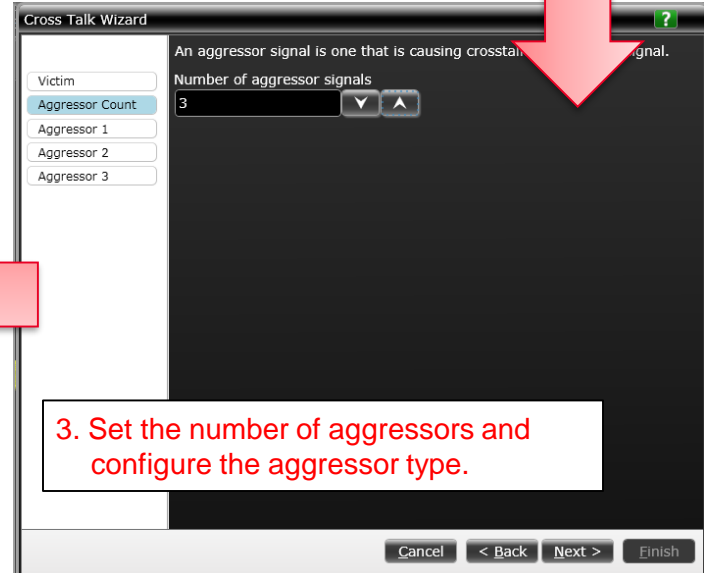
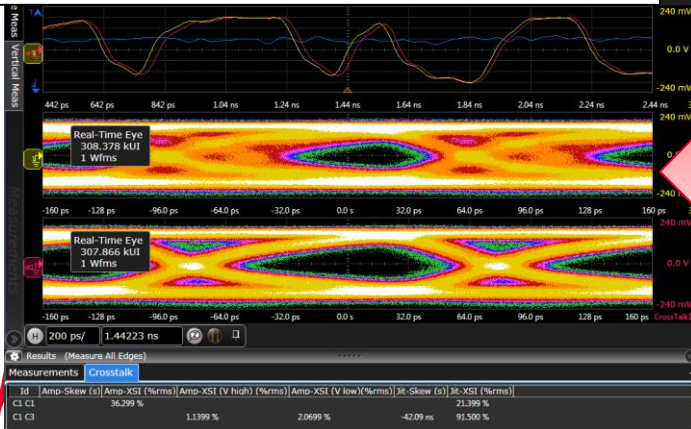

3. Set the number of aggressors and configure the aggressor type.

Agenda

- Crosstalk Overview and Types
- Challenges with Crosstalk Analysis Today
- Overcome Challenges with Keysight Crosstalk Analysis App
- **Analyze and Remove Crosstalk**
- Theory of Operation
- Summary

NEXT and FEXT on Serial Victim



No Serial Aggressor



NEXT & FEXT Aggressors

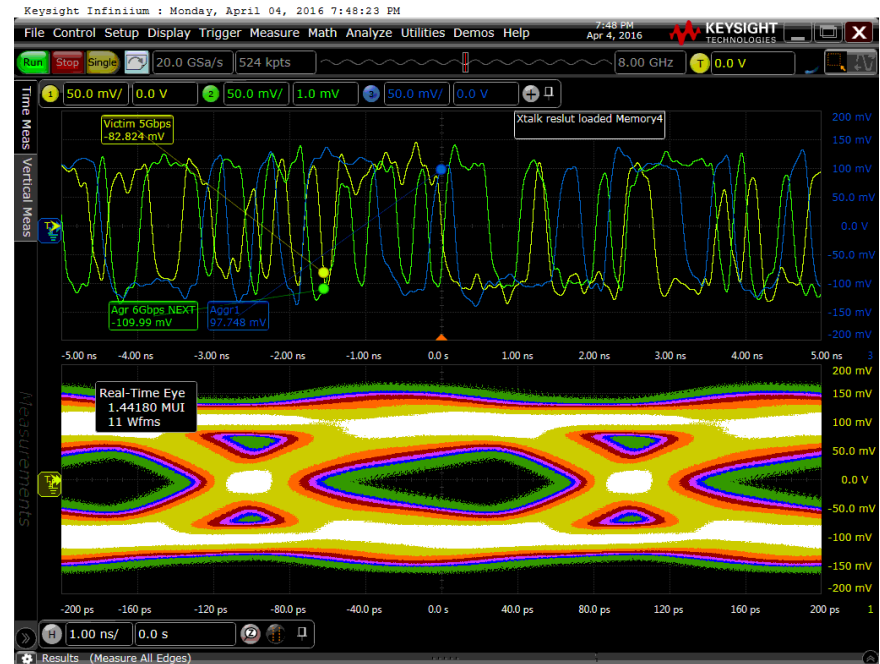

Removing NEXT and FEXT with Crosstalk App

With NEXT and FEXT Aggressors Off

NEXT and FEXT Aggressors Off

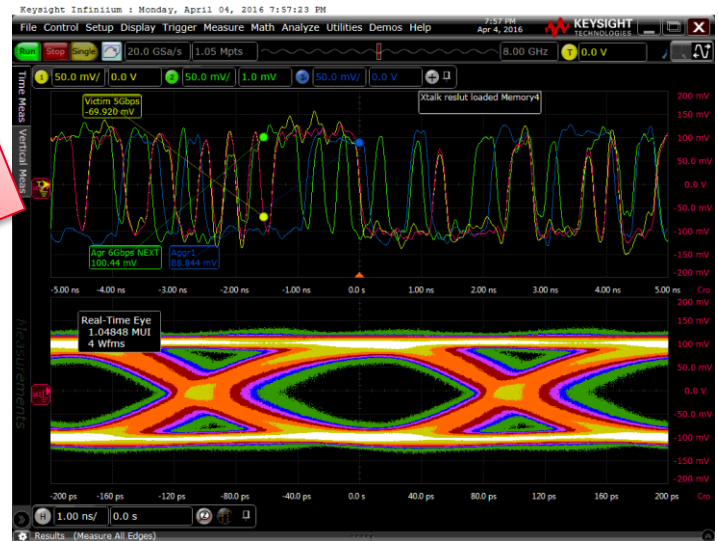

NEXT and FEXT Removed

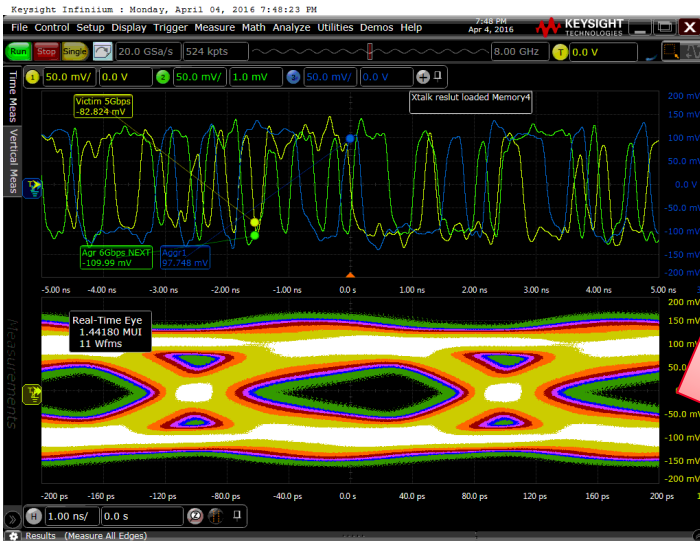

Select signals to remove their contributions

	Name	Signal Type
<input checked="" type="checkbox"/>	XT from Signal2	Serial Data
<input checked="" type="checkbox"/>	XT from Signal3	Serial Data
<input type="checkbox"/>	Ideal Victim Wfm	Serial Data
<input type="checkbox"/>	ISI of Victim	Serial Data
<input type="checkbox"/>	Unknown XT + Noise	Serial Data

Use the crosstalk app to remove effect of NEXT and FEXT

Power Supply Aggressor (VDAN) on Victim

Voltage Dependent Amplitude Noise

No Power Supply Aggressor

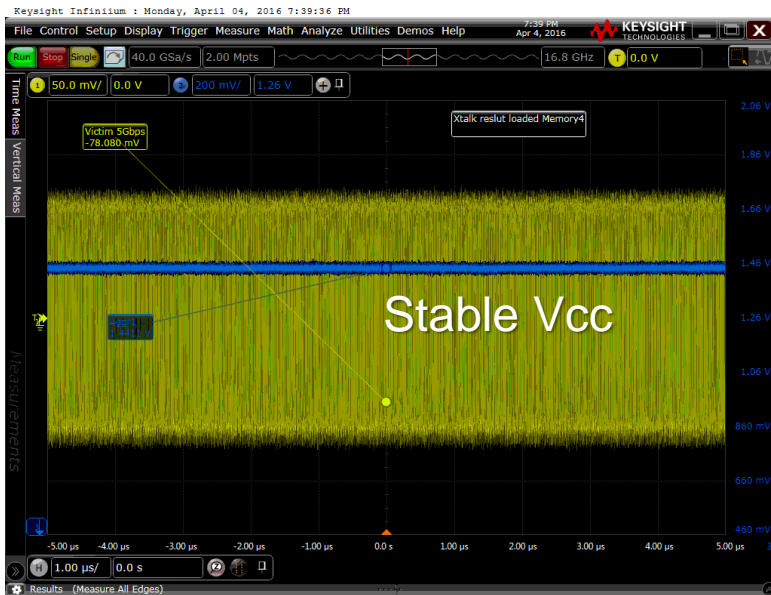

With Power Supply Aggressor

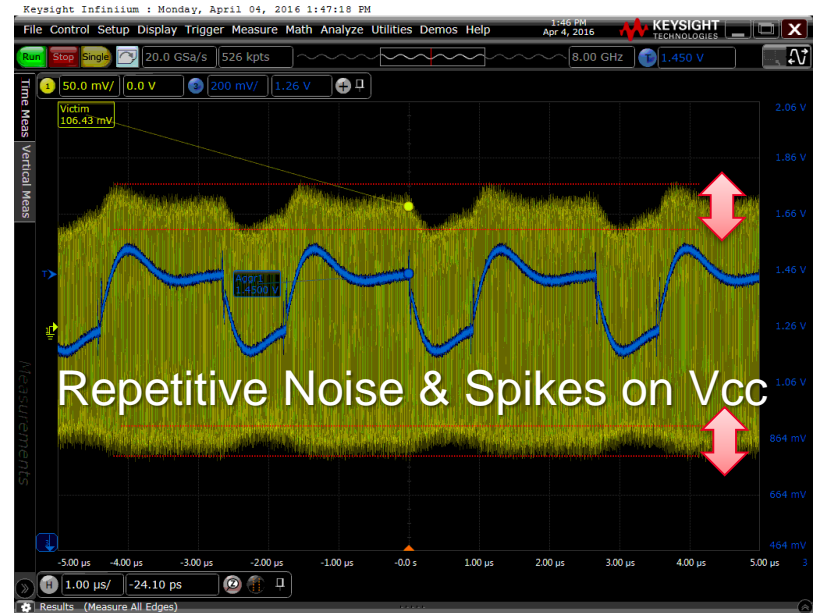

Removing Power Supply Aggressor (VDAN)

With Power Supply Aggressor

Power Supply Aggressor Removed

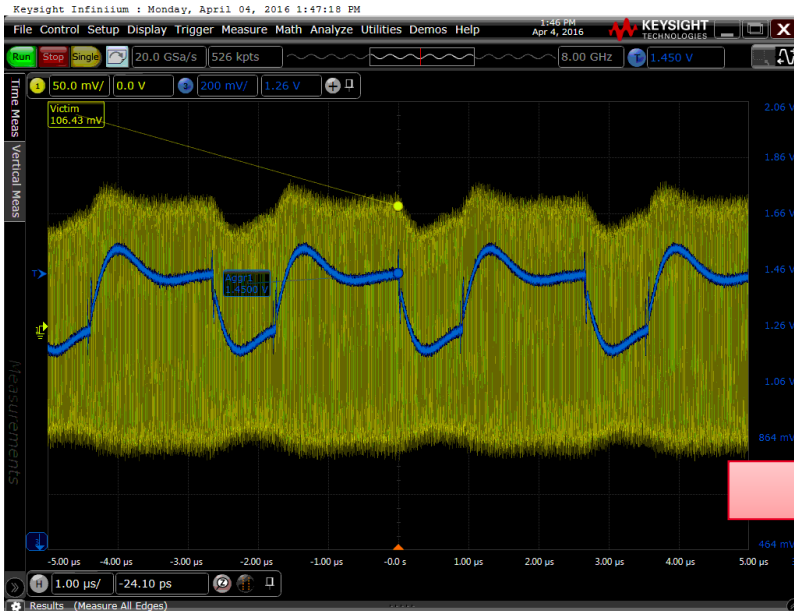

CrossTalk

Setup Wizard... Advanced Configuration...

Enable

Xt2 Signal1 X Signal3 X +

Name: Signal3 Source: Channel 3

This signal is a Victim

This signal is an Aggressor

Signal Type

Power Supply

Use the crosstalk app to remove effect of power supply crosstalk

Removing Power Supply Aggressor (VDAN)

Victim With Power Supply Aggressor

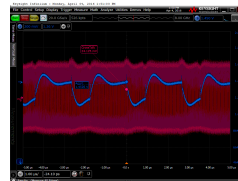
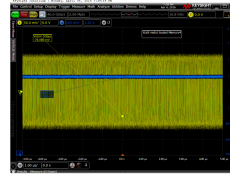
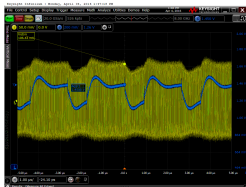
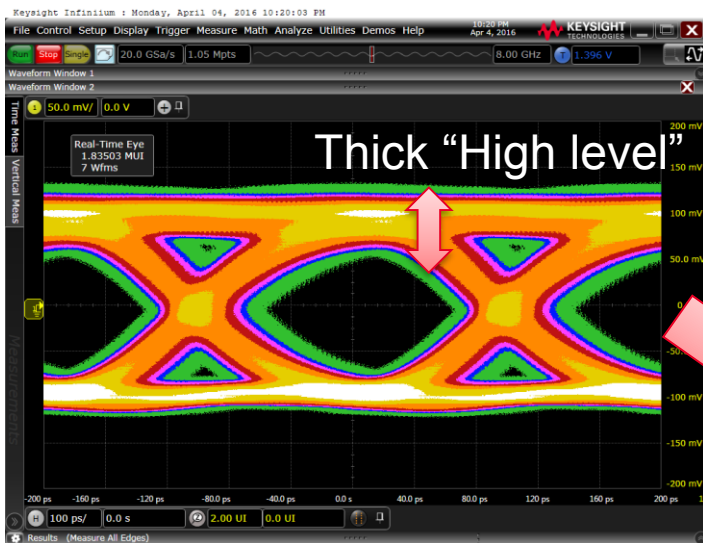

Measured Victim Without Aggressor

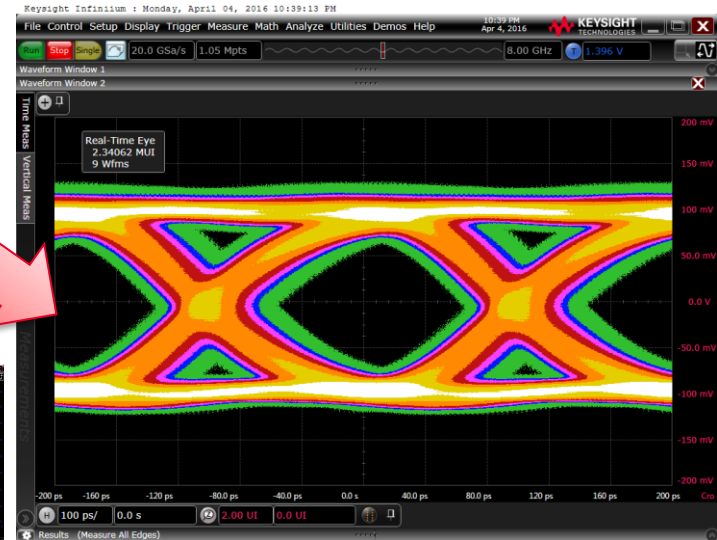
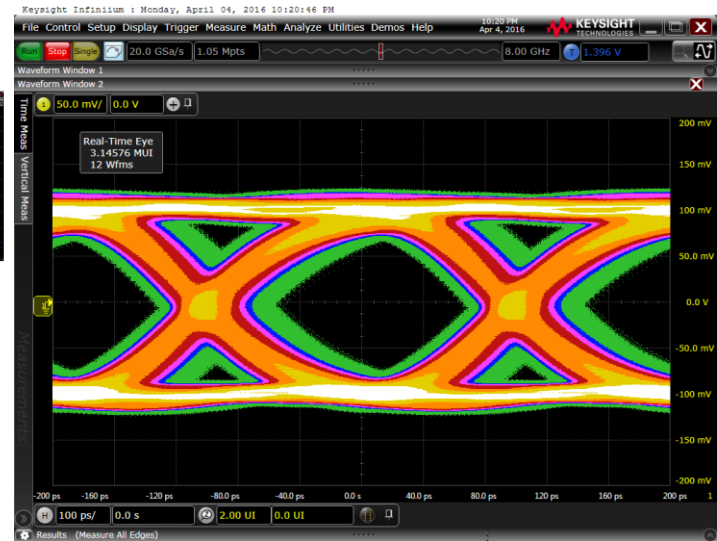

Victim after Power Supply Aggressor removed

Power Supply Induced Jitter (PSIJ) Crosstalk on Victim

No Power Supply Aggressor

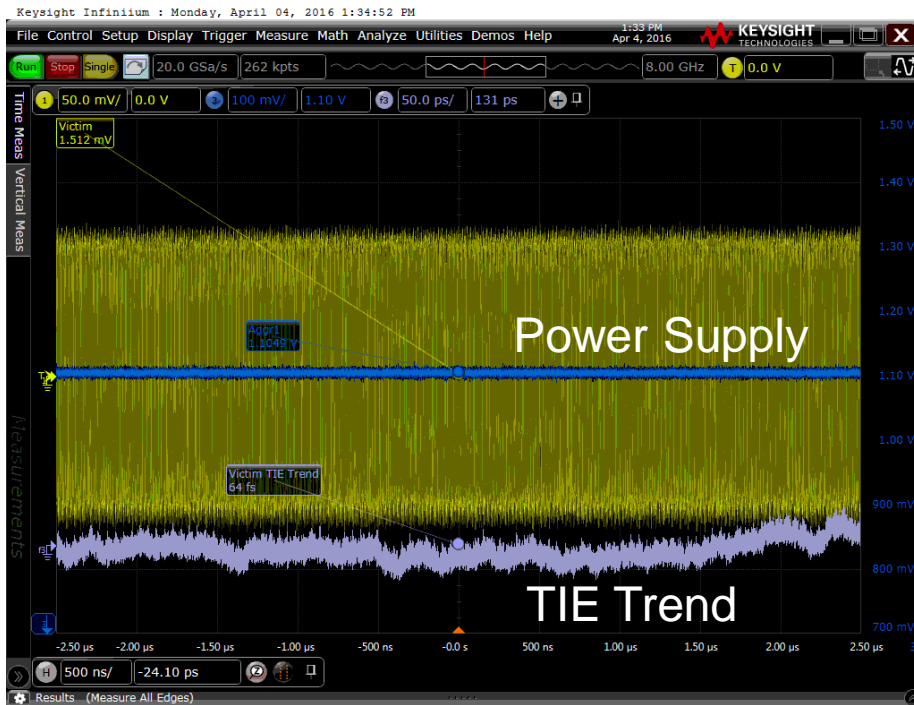

With Power Supply Aggressor

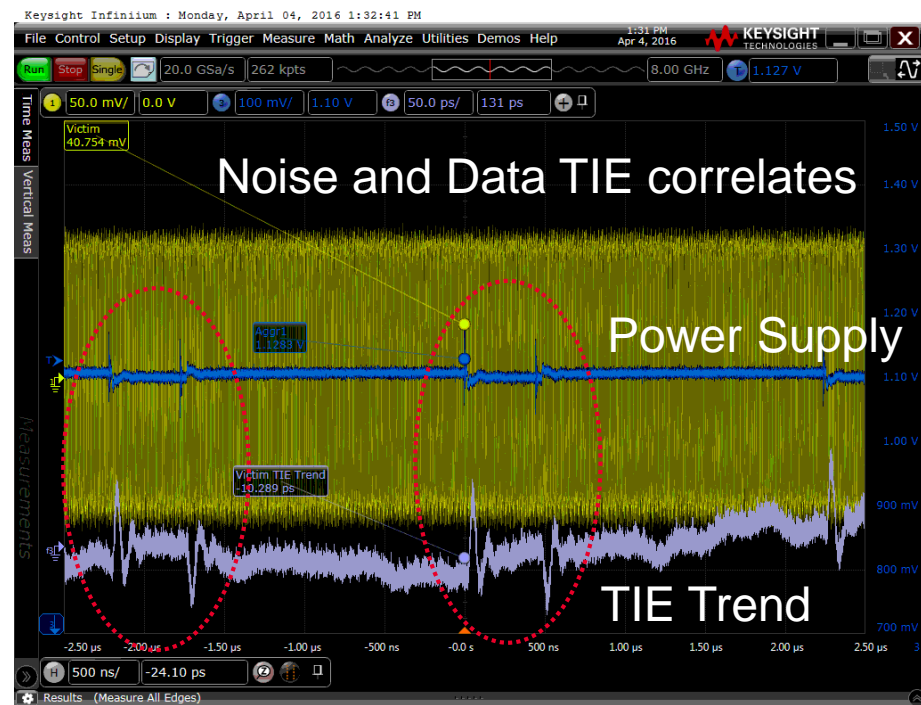

Removing PSIJ from Victim

With Power Supply Aggressor

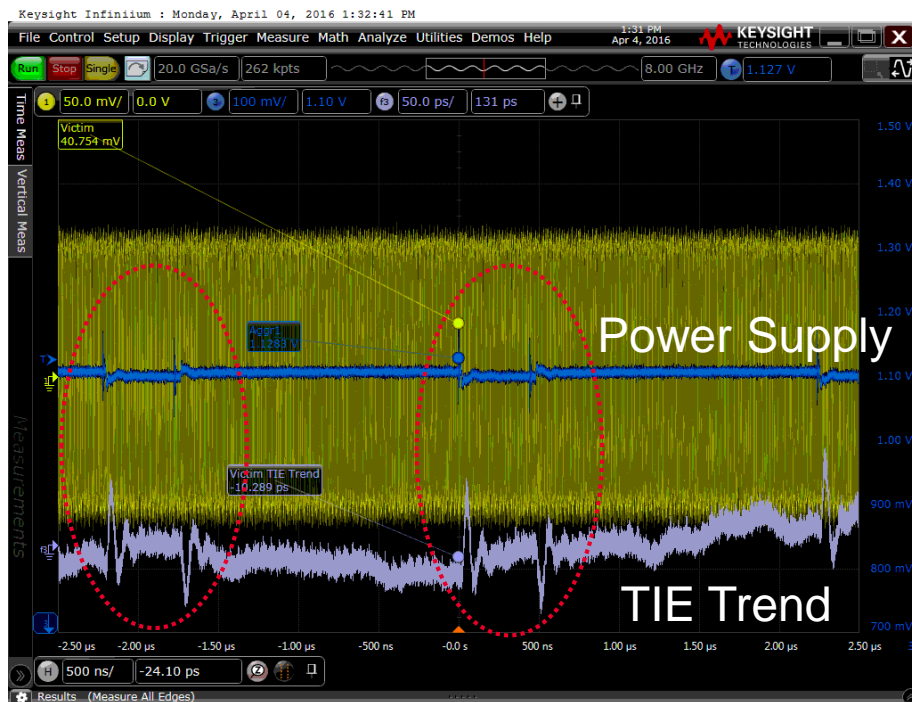

Power Supply Aggressor Removed with Improvement on Data TIE Trend

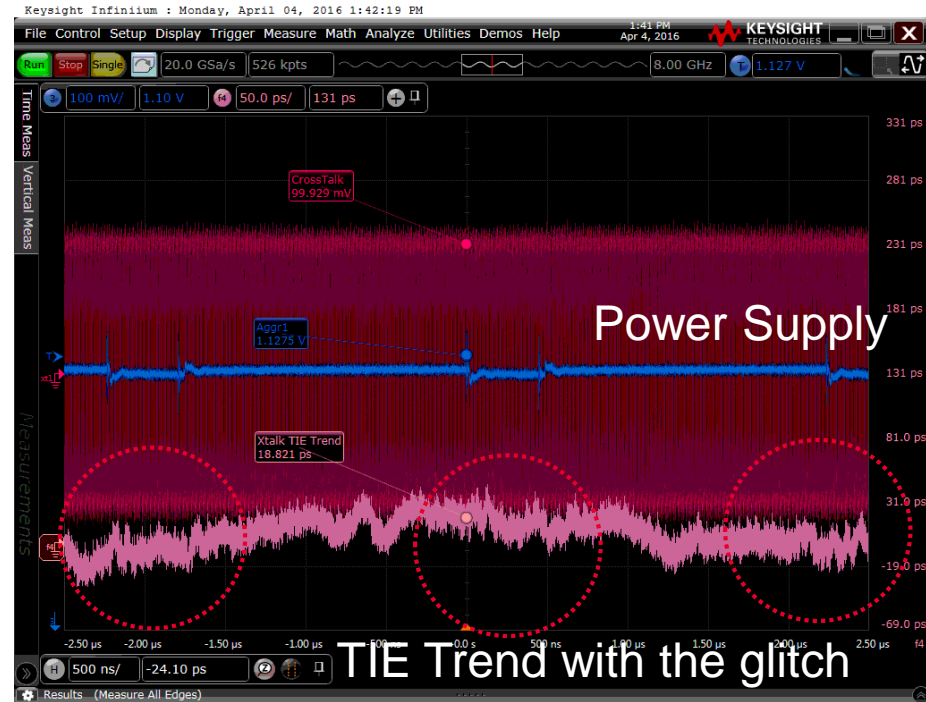

Removing PSIJ from Victim

Measured Victim with Power Supply Aggressor

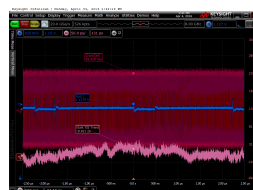
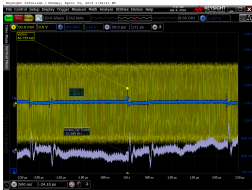
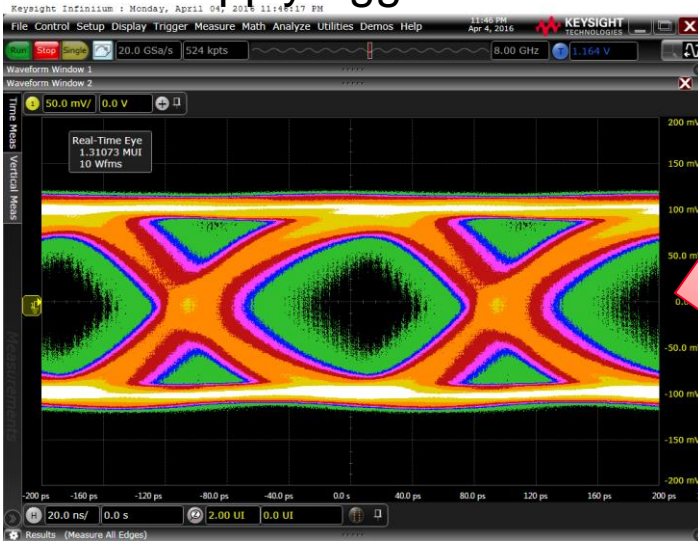

Measured Victim Without Aggressor

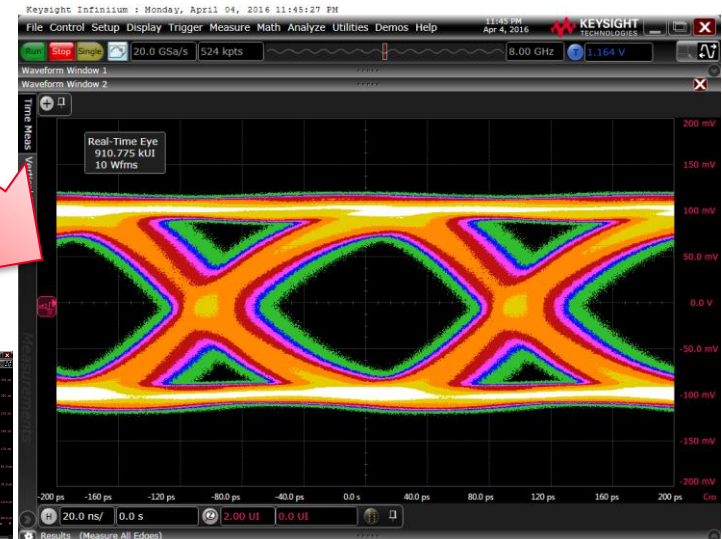

Victim after Power Supply Aggressor removed

Crosstalk Results

Understanding the results



Victim: Aggres- sor pair	ISI and Serial Data Crosstalk		Power Supply Crosstalk			
	Crosstalk signature deskew	Distortion (rms) affecting victim	Vertical distortion (rms) affecting victim logic high	Vertical distortion (rms) affecting victim logic low	Crosstalk signature deskew	Time Distortion (rms) affecting victim

Vic:Aggr	Volt, Skew (s)	Volt, Error (rms)	V high, Error (rms)	V low, Error (rms)	Time, Skew (s)	Time, Error (rms)
c1:c1		14%				14%
c1:c2	-25.00 ps	8%				
c1:c3			6%	2%	-227.0 ns	18%

ISI
Serial data XT
Power supply XT

Signature of the serial data is found after de-skewing by 25 ps	14% distortion from ISI. 8% distortion from serial data crosstalk.	6% of the power supply signature is found in the logic level high.	2% of the power supply signature is found in the logic level low.	Signature of the power supply is found in the TIE after de-skewing by 227 ns	14% distortion of the TIE comes from ISI and 18% comes from the power supply
---	--	--	---	--	--

Crosstalk Error RMS and PP Calculation

Crosstalk on victim,
correlated to
aggressor signature

RMS provides more
stable results
PP shows the peaks
of the crosstalk

RMS and PP of the
victim waveform

RMS does not change
much between both
crosstalk waveforms

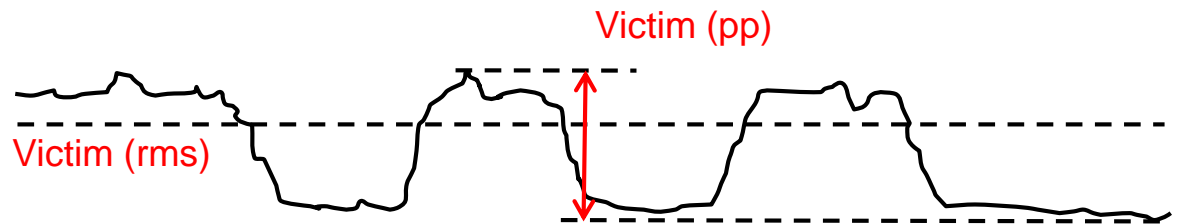
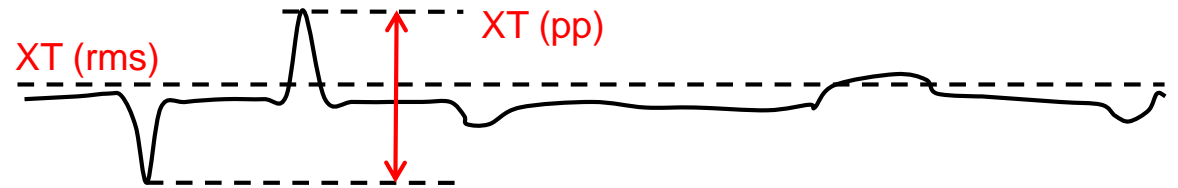
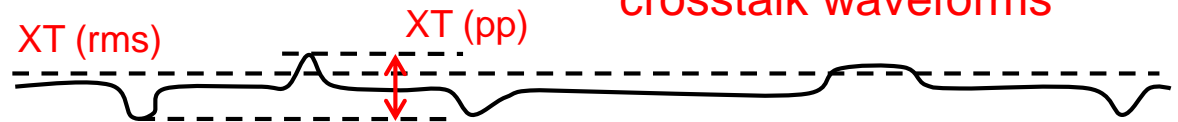

$$\text{Volt, Error (rms)} = \frac{\text{XT (rms)}}{\text{Victim (rms)}} \%$$

$$\text{Volt, Error (pp)} = \frac{\text{XT (pp)}}{\text{Victim (pp)}} \%$$

ISI Error RMS and PP Calculation

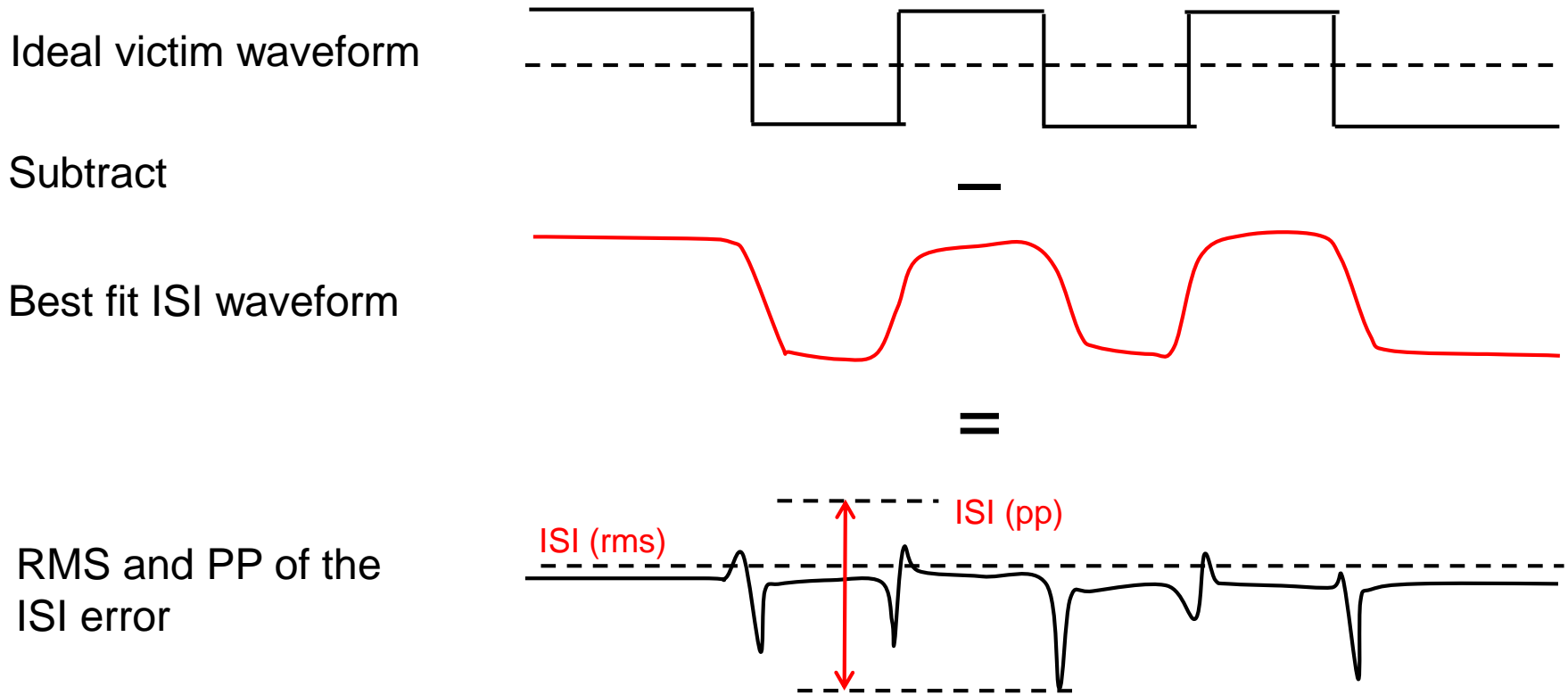

$$\text{Volt, Error (rms)} = \frac{\text{ISI (rms)}}{\text{Victim (rms)}}$$

$$\text{Volt, Error (pp)} = \frac{\text{ISI (pp)}}{\text{Victim (pp)}}$$

Jitter Improvement Without Power Supply Crosstalk

Waveforms with and without crosstalk are feed into EZJIT Plus for jitter analysis.

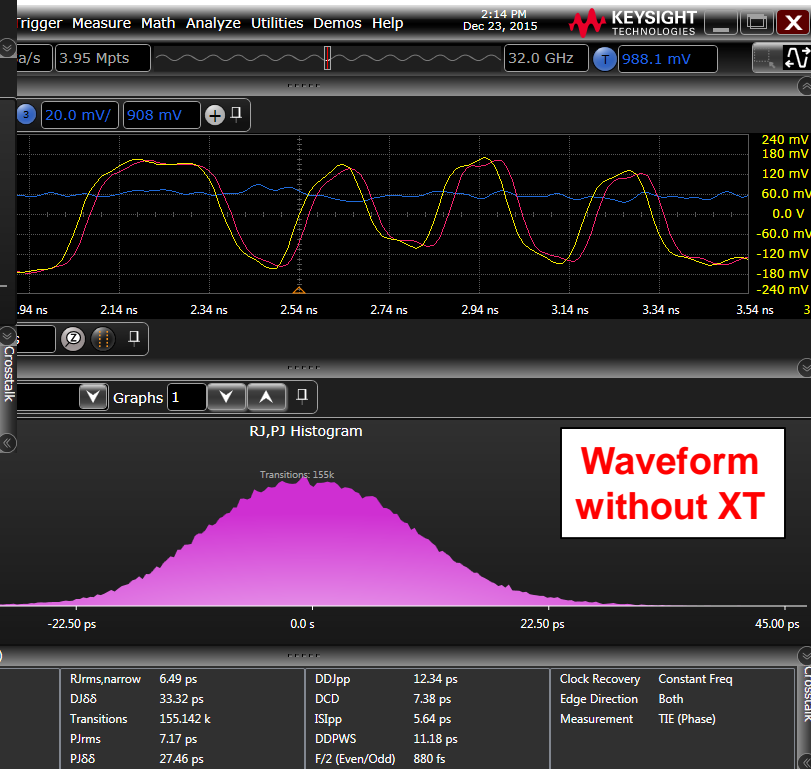
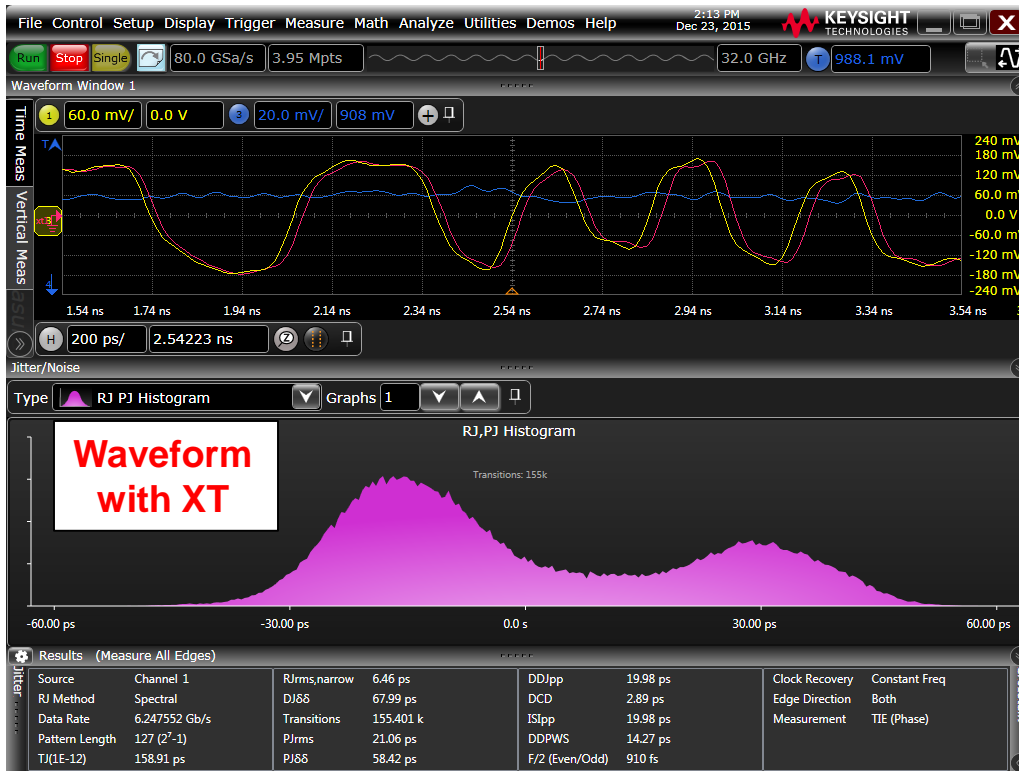

TJ = 158ps
PJdd = 58ps
DJdd = 68ps

An improvement of 20% to total jitter without crosstalk.



TJ = 124ps
PJdd = 27ps
DJdd = 33ps

Keysight
Measurement
Forum

Agenda

- Crosstalk Overview and Types
- Challenges with Crosstalk Characterization and Debug
- Overcome Challenges with Keysight Crosstalk Analysis App
- Application Features & Test Setup
- Crosstalk Analysis Results
- **Theory of Operation**
- Summary

Crosstalk Network Models

- The crosstalk application constructs different types of crosstalk models from the measured waveforms depending on the victim and aggressor signal types.
- In the simplest case, when both victim and aggressor are serial data signals, the model is a linear n-port transfer function model.
- Probing the two serial data channels provides the input waveforms to the crosstalk application.

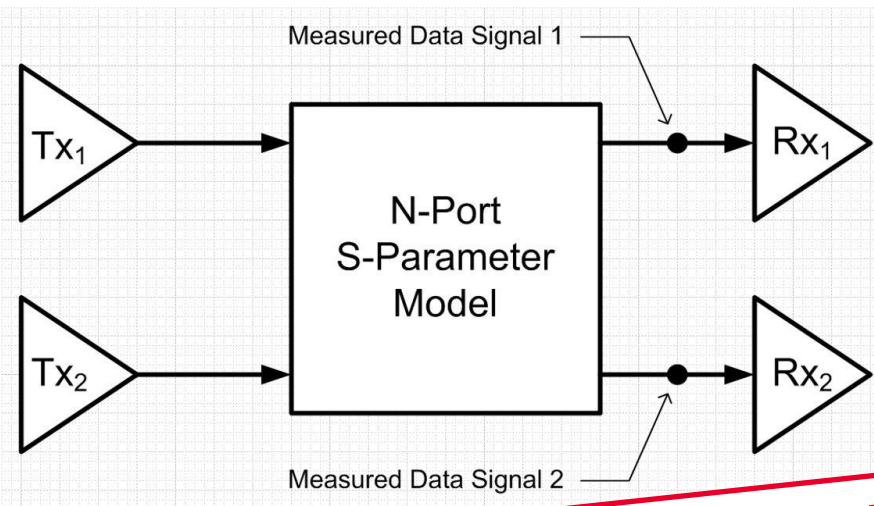

A 4-port network model for two parallel transmission lines. The black dots show possible probe locations at the far end.

PATENT PENDING

Crosstalk Network Models (continued...)

- The application begins analyzing the waveforms by extracting the serial clock and data pattern of each.
- It then uses the ideal data pattern as input to the 4-port linear crosstalk model and computes the best-fit transfer function model, which transforms the ideal waveforms into the actual measured waveforms.
- Within the model, h_{11} and h_{22} represent the signal's ISI while h_{21} and h_{12} represent the coupling or crosstalk between the two signals. This approach allows the crosstalk analysis application to remove the effect of either the crosstalk, ISI or both crosstalk and ISI from the measured waveforms.

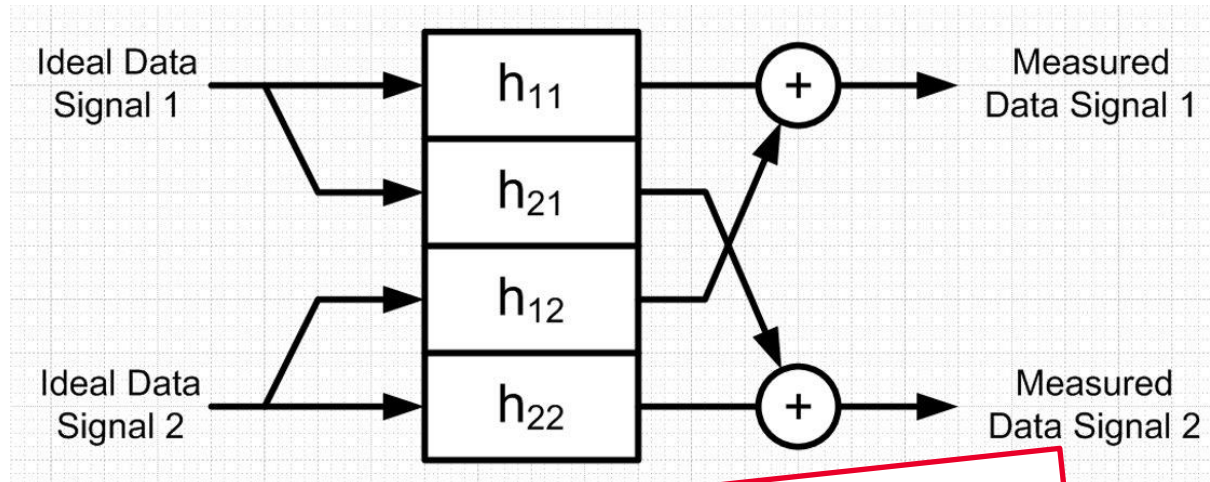

The crosstalk analysis application computes a 4-port linear crosstalk model, which transforms the ideal waveforms into the actual measured waveforms.

Agenda

- Crosstalk Overview and Types
- Challenges with Crosstalk Characterization and Debug
- Overcome Challenges with Keysight Crosstalk Analysis App
- Application Features & Test Setup
- Crosstalk Analysis Results
- Theory of Operation
- **Summary**

Most Comprehensive Crosstalk Analysis Application

N8833A/B Key Value Propositions

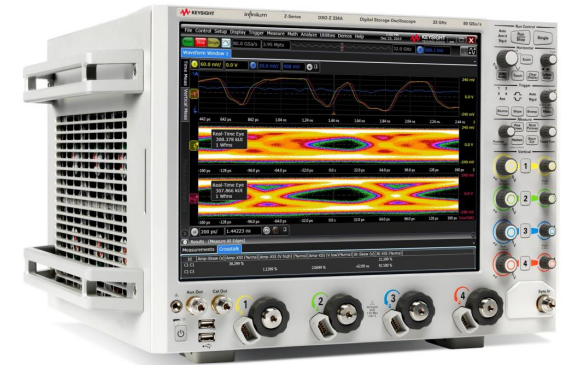

Crosstalk Identification

Crosstalk Quantification

Crosstalk Removal for Analysis

Save Weeks of Crosstalk Debugging in Time and Effort

Assist in Making Important Design Decisions

Q and A Session

Keysight
Measurement
Forum

Page 41

