



SERIAL
新曄集團

USB Type-C Introduction

JH Kim
jh.kim@serialsystem.com

2017-03-27

Your Integral Component to Success

Agenda

What is USB Type-C?

What is USB Power Delivery??

TI USB Type-C Solution

- USB-C Controllers & Signal Conditioners
- USB-C/PD Controllers (Fully Integrated)
- USB-C & USB-C/PD Controllers
- USB-C Protection Devices
- USB-C Thermal Protection
- End Application Block Diagrams by Product



SERIAL
新擘集團

What is USB Type-C?

Your Integral Component to Success

Type-C/PD Technology Overview

USB - C



Micro - B



What is Type-C/PD

USB-C/PD is a wide spread interface that is scalable for power & signaling. It is a specification for a reversible-plug connector for USB devices and cabling.

When to use Type-C/PD



Why Now?

- A single USB Type-C connector can deliver functions that several connectors provide today in our electronic gadgets.
- Standard type-c now offer more than twice of existing BC1.2 power and type-c PD now offer up to 100W of power.
- The more demand for electronics end applications, the more demand for high power and faster data/video.

The Evolution of USB

1998



USB1.x
Low Speed
LS: 1.5Mbps
Full Speed
FS: 12Mbps

2000



USB2.0
High Speed
HS: 480Mbps
FS, LS

2001



USB OTG
Device can be
Both Master and
Slave

2008



USB3.0
USB3.1 Gen 1
Super Speed
SS: 5Gbps

2013



USB3.1 Gen 2
Super Speed+
SS+: 10Gbps

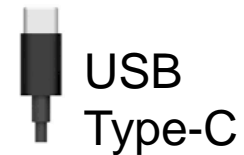

USB Today

The “original” USB has just four electrical contacts
5V PWR (VBUS) and GND
D+ and D- Data busses
First connector to combine both Data and Power!
USB 3.0 added five more
Super Speed TX pair
Super Speed RX pair
Another GND

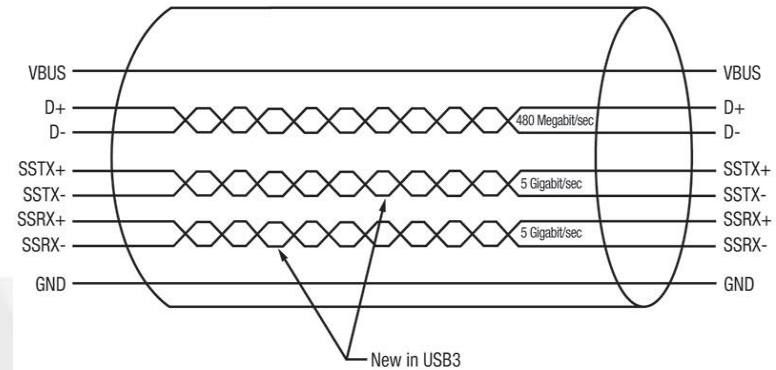
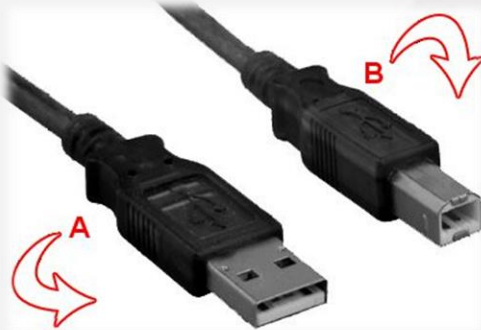

USB has been a great workhorse, but:

- Connectors are clumsy
- Different connectors at either end for Host/Device
- Can never find the right cable with the right two connectors
- Limited data speeds and connectivity

The USB Signal Fundamentals

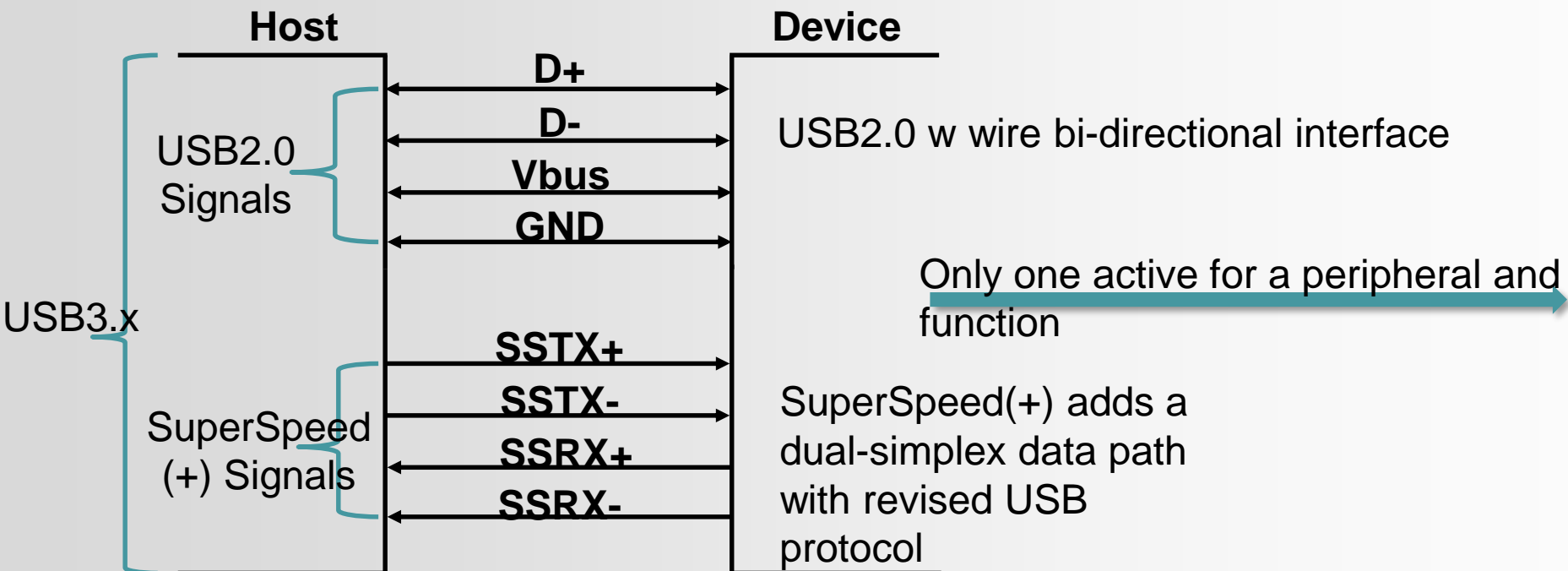

What is USB Type-C?

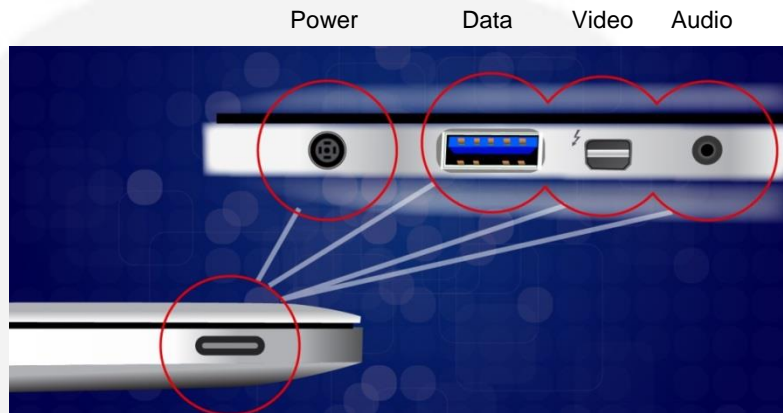

USB-C

USB Type C is a new receptacle, plug, and cable standard that is compatible with existing USB interfaces:

- First connector supporting power, data and video
- First TI solutions began sampling end of 2014
- Major rollout throughout 2015

Features:

- Small form factor connectors
- Flippable connectors and reversible cable that gives a more user friendly experience
- Supports USB 3.1 (10Gbps)
- New USB Type-C Current (5V / 1.5A / 3A)
- Supports USB PD (up to 20V / 5A)
- Supports “Alternate Modes” through the same port

TI expects the Type-C connector will eventually replace ALL other USB connectors

The USB Connectors

USB2.0

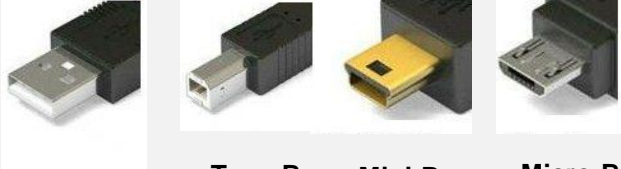

Type-A Type-B Mini-B Micro-B

USB3.0



Type-A Type-B Micro-B

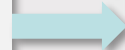

One size for USB2.0, 3.0, 3.1



Type-C

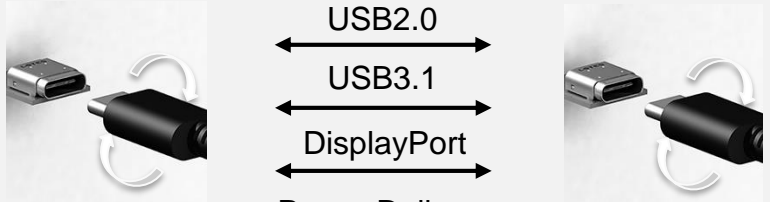

USB2.0
USB3.1
DisplayPort
Power Delivery

In the Beginning USB 2.0 Cable

The “original” USB has just four electrical contacts
 5V PWR (VBUS) and GND
 D+ and D- Data busses
 USB 2.0 was First connector to combine both Data and Power!

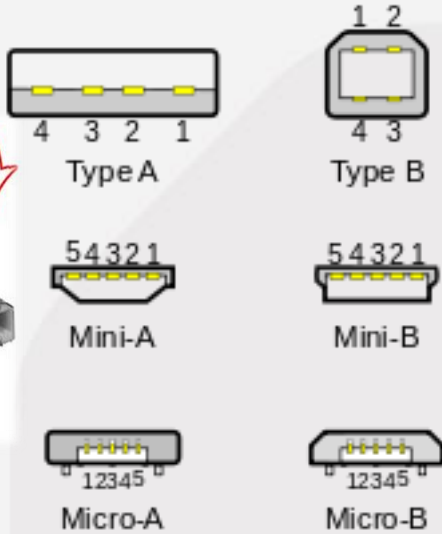
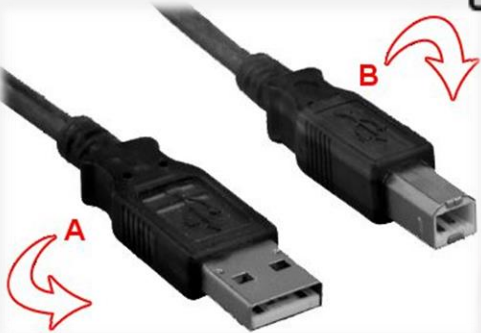
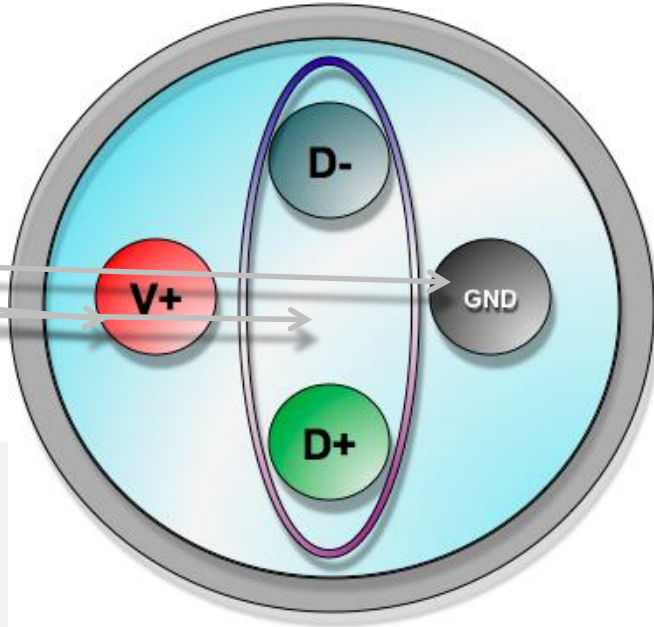

USB 2.0 has been a great workhorse, but:

- Connectors are clumsy
- Different connectors at either end for Host/Device
- Not easy to find the right cable with the right two connectors
- Limited data speeds and connectivity

USB 3.0/3.1 Cable

USB 3.0 added five more

- Super Speed TX pair
- Super Speed RX pair
- Shielded GND around RX/TX pairs
- These new wires required new connectors

- Now we have high speed data!
- But connector incompatibility
 - USB 3.0 was not widely adopted

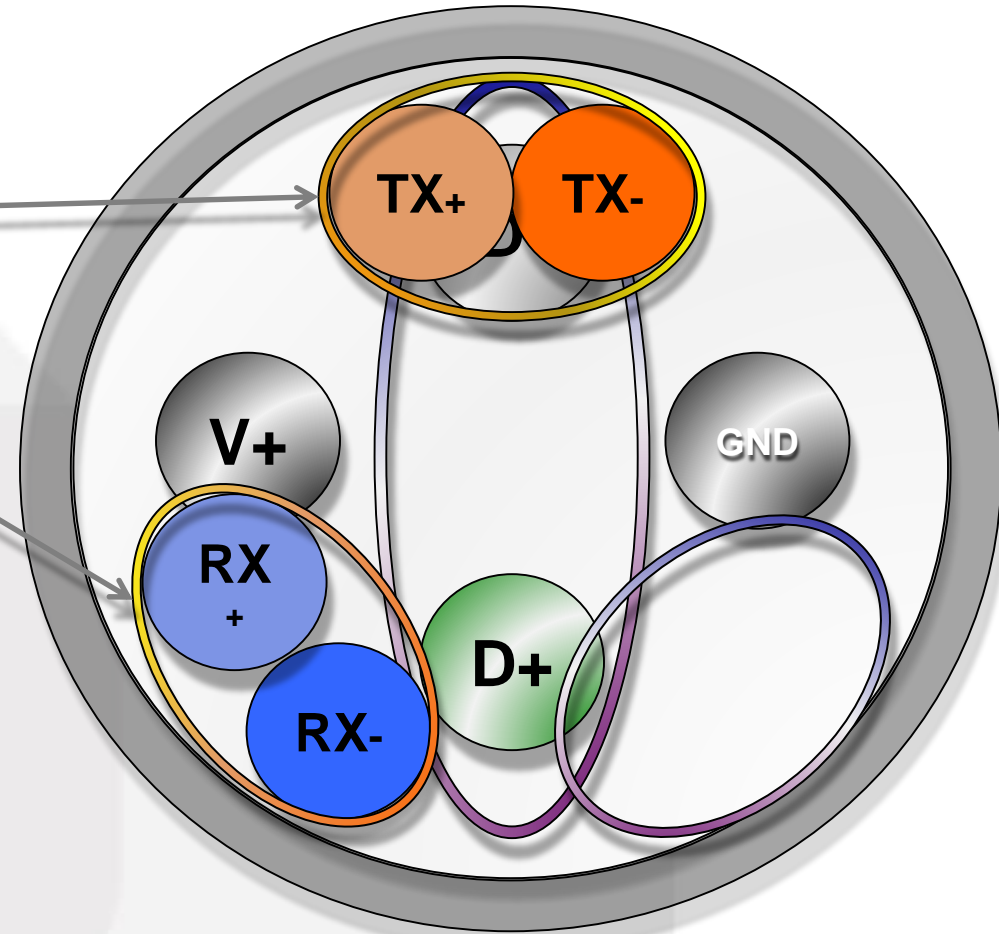

USB Type C Cable

USB Type C Added

- CC (Configuration Channel)
- V_{CONN} Support (optional)
- SBU (Side Band Unit)

- **CC** Is used to Support USB PD and help determine role
- **V_{CONN}** Connects to the opposite CC pin this is used for Active cable Power
 - 5V and can support 1W of power
 - Can be used to recondition signals
 - Can support USB PD ID to support up to 5A of current
- **SBU** is used for Audio (i.e. Microphone)

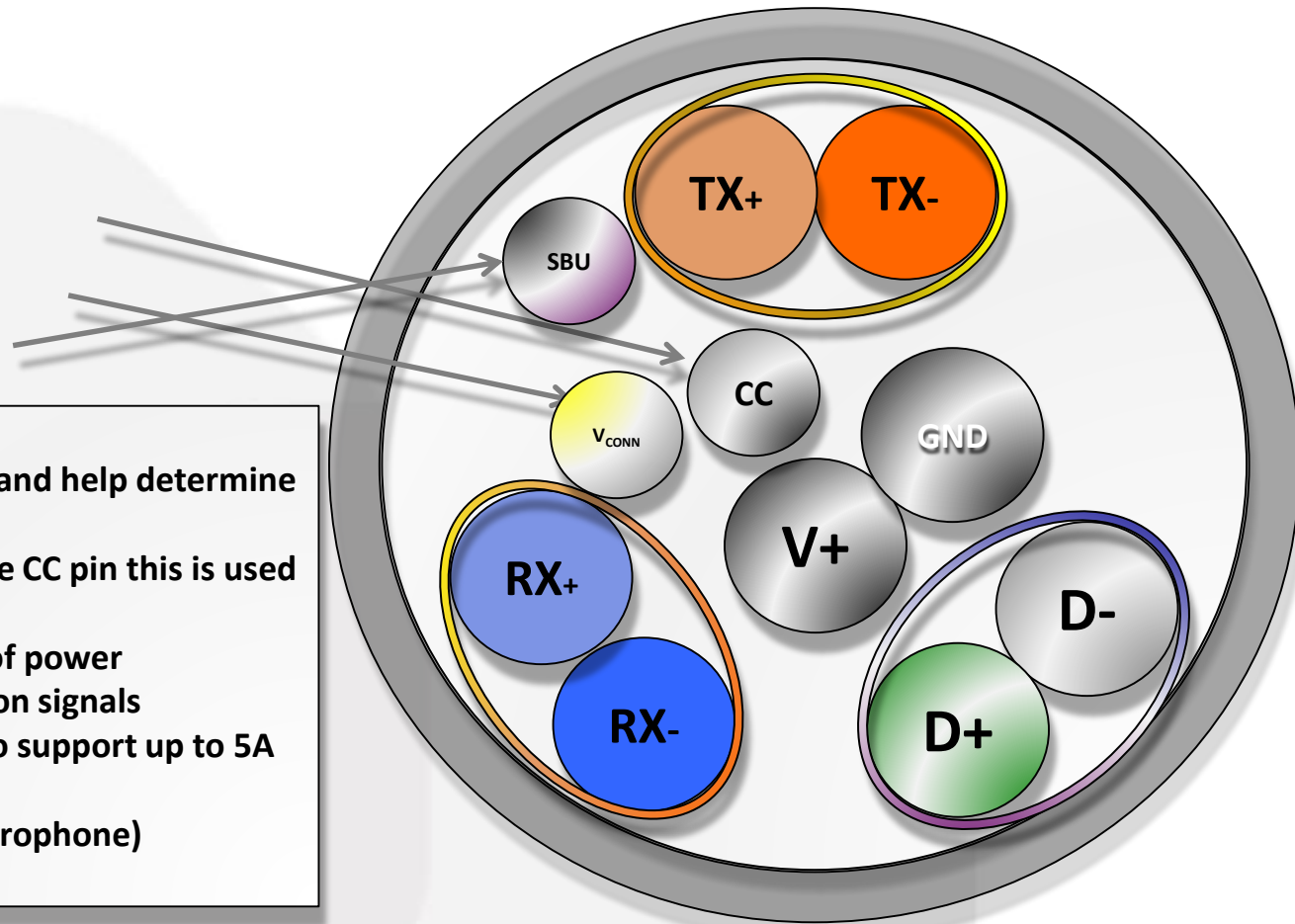

USB Type-C Receptacle

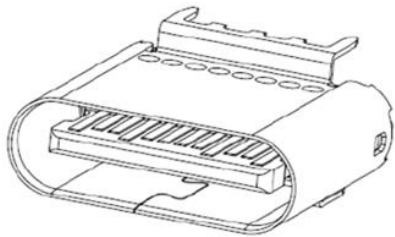

USB Type-C Cable

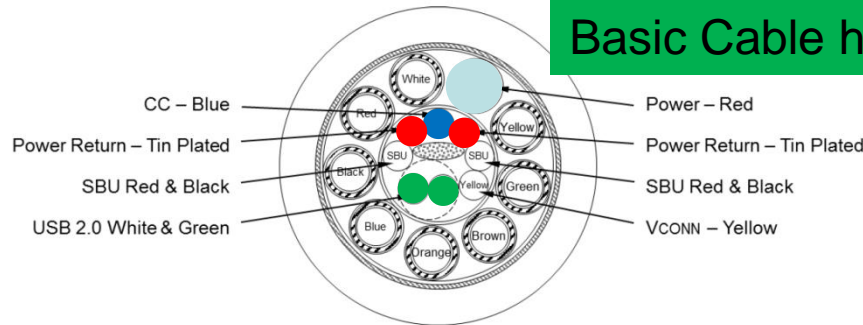

Basic Cable has only 6 wires

OD = 4.8mm

Coax are SS pairs – specific pairs not defined in cable

USB Type-C Plug

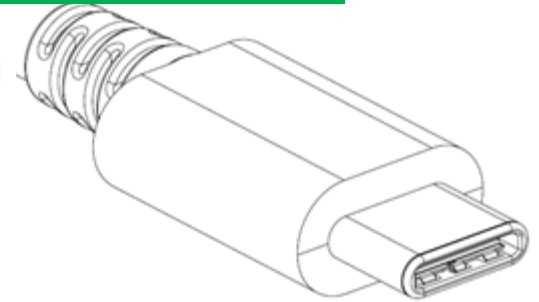

Figure 2-1 USB Type-C Receptacle Interface (Front View)

A1	A2	A3	A4	A5	A6	A7	A8	A9	A10	A11	A12
GND	TX1+	TX1-	VBUS	CC1	D+	D-	SBU1	VBUS	RX2-	RX2+	GND
GND	RX1+	RX1-	VBUS	SBU2	D-	D+	CC2	VBUS	TX2-	TX2+	GND
B12	B11	B10	B9	B8	B7	B6	B5	B4	B3	B2	B1

Figure 2-2 USB Full-Featured Type-C Plug Interface (Front View)

A12	A11	A10	A9	A8	A7	A6	A5	A4	A3	A2	A1
GND	RX2+	RX2-	VBUS	SBU1	D-	D+	CC	VBUS	TX1-	TX1+	GND
GND	TX2+	TX2-	VBUS	VCONN			SBU2	VBUS	RX1-	RX1+	GND
B1	B2	B3	B4	B5	B6	B7	B8	B9	B10	B11	B12

USB Type-C Flippable Receptacle Interface

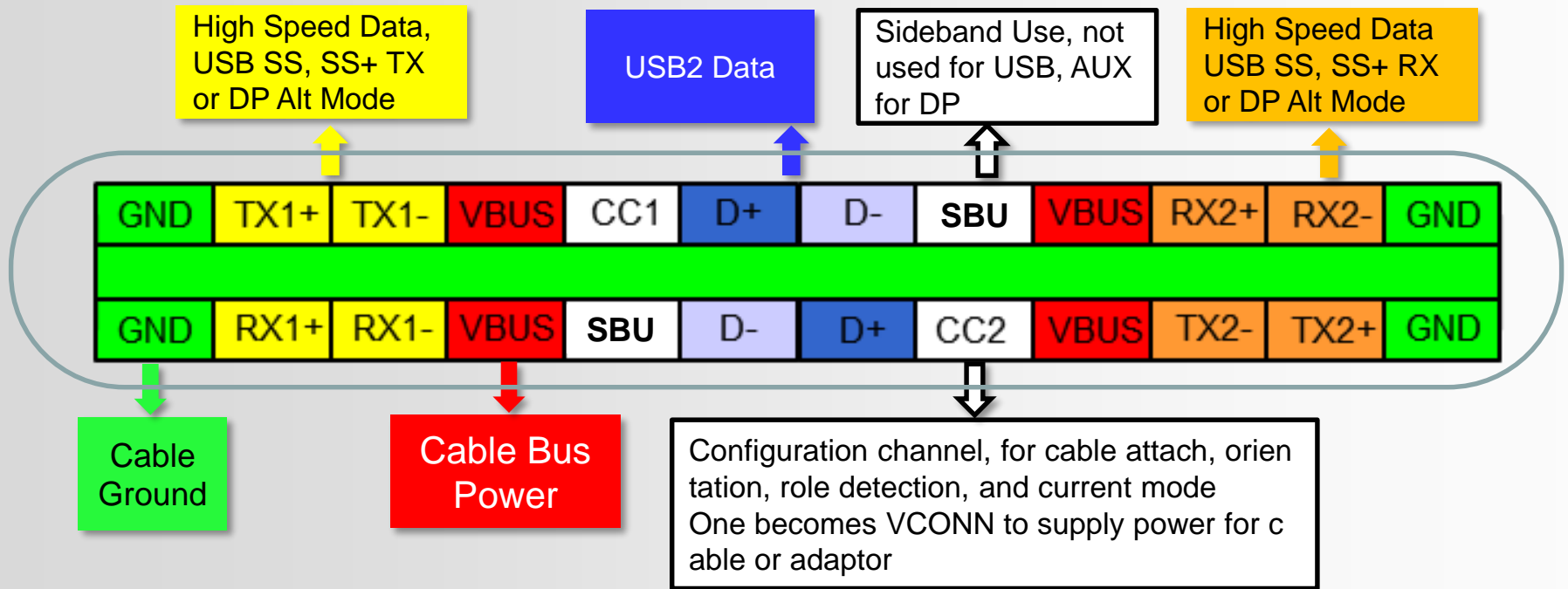

USB Type-C Connectors

USB Type-C receptacle type

- The Type-C connector is a reversible connector that can be used in either orientation.
- USB Type-C is a standard for connecting devices between a host and a peripheral device.
- A host-to-host connection can be made via the connector.
- With USB Type-C, a single connector provides:
 - USB
 - 20V

**NOTE: A Specification for A current*

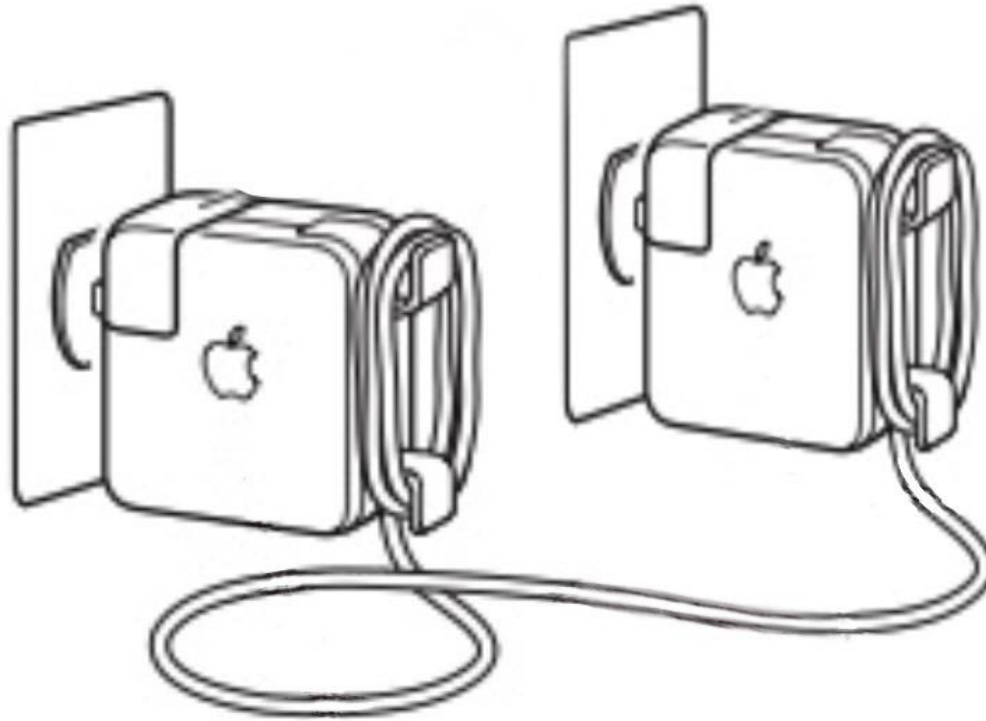

This also does not work

modes:

or device

IP connecti

unctions

al-role port

orks

orks

orks*

USB Type-C Operation Modes

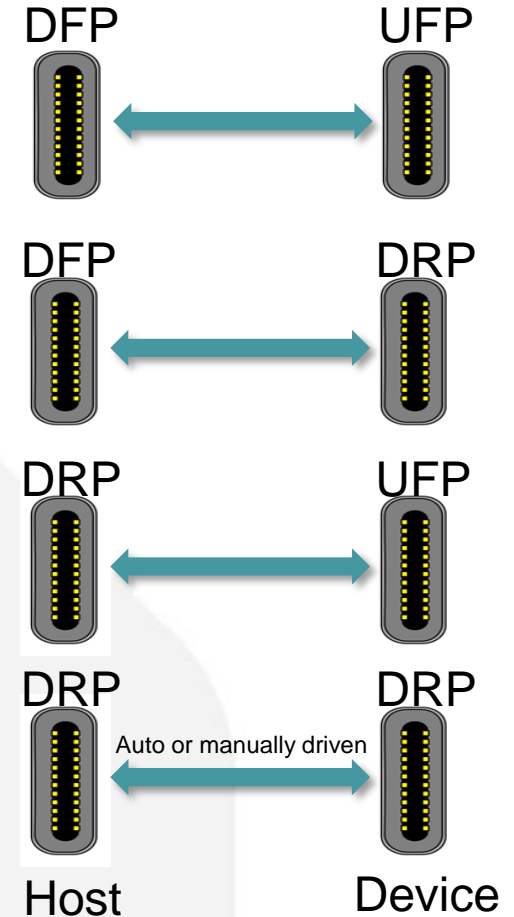
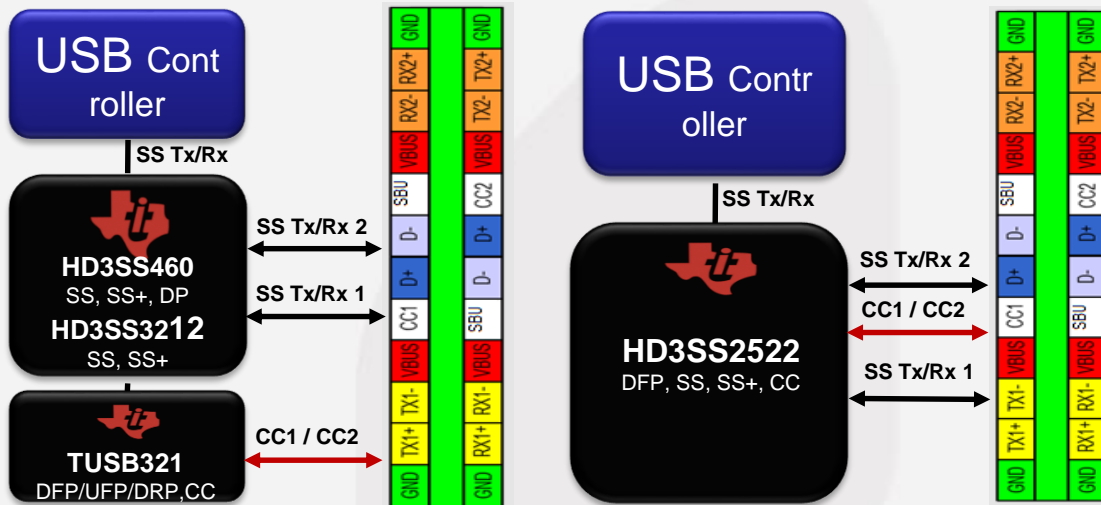
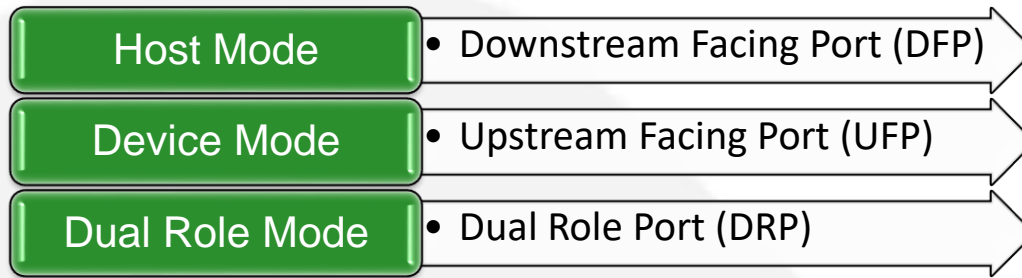

Configure USB Type-C Using Switch/Mux

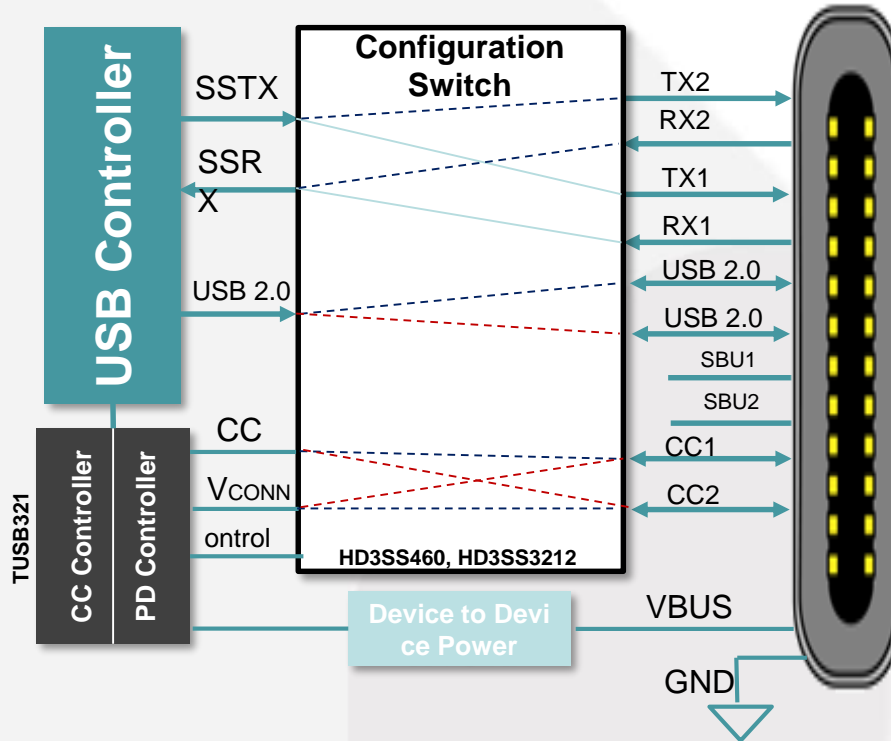

- USB Type-C switch can reduce pin out and complexity in USB controller
- Same switch required in both host and device
- Switch can be integrated with USB signal conditioner and CC functions

DFP and UFP and DRP Oh My!

DFP - Downstream Facing Port

- Normally this would be in an AC adapter or a USB Hub
- This is what you plug your device into (also known as a UFP)

Only 1 USB Type C port!

UFP - Upstream Facing Port

- This is the device you connect to the host
- Could be a phone, tablet, portable gaming system etc.

DRP - Dual Role Port

- This is a port that can change from DFP to UFP or visa-versa
- Typically a notebook
- Could be a power bank



Providing the flexibility of Type-C

Functionally the Configuration Channel (CC) is used to serve the following purposes:

- Detect connect of USB ports,
- Resolve cable orientation and twist connections to establish USB data bus routing
- Establish DFP and UFP roles between two connected ports
- Discover and configure power: USB Type-C current modes or USB Power Delivery
- Discovery and configuration of optional Alternate and Accessory modes

Typical CC flow for DFP to UFP configuration:

Detect valid connection



Establish USB power method



Configure Alternate Mode



SERIAL
新曄集團

What is USB Power Delivery?

Your Integral Component to Success

Why use USB PD?

- Enables higher voltage, up to 20V
 - 5V, 9V, 15V, and 20V satisfy most customer needs.
- Up to 100W power over USB cable
- Which port provides power is negotiable
 - DFP can be provider or consumer.
 - UFP can be provider or consumer.
- Efficient power management across multiple peripherals
- DFP has cold socket to conserve power
- Co-existence with legacy USB products
- Enables Alternate Modes

Typical PD flow

VBUS initially defaults to 5V, 500mA power supply

5V



USB Power Delivery negotiation over CC wire

5V



Power supplied over VBUS at the rate negotiated

20V

← Not related to power, but USB PD required

USB-PD Over USB Type-C

Precedence	Mode of Operation	Nominal Voltage	Maximum Current
Highest	USB PD	Up to 20 V	Up to 5 A
	USB Type-C current @ 3A	5 V	3 A
	USB Type-C current @ 1.5A	5 V	1.5 A
	USB BC1.2	5 V	Up to 1.5 A
	USB 3.1	5V	900 mA
Lowest	USB 2.0	5V	500 mA

Port Power Roles

USB PD over Type-C is negotiated through CC wire, port power roles are now defined separately from the port data roles.

- **Provider:** device can only provide power
- **Consumer:** device can only receive power
- **Consumer provider:** The device can act as either a consumer or provider. This is only possible for devices that support USB PD



5A versus 3A Cables

All USB Type-C cables can support 3A.
There are two types of Type-C cables that may support 5A.

1. The 5A cable contains an E-marker chip that the Source can read which indicates its current capability.
2. The cable is a captive cable that is permanently attached at one end.

Type-C 5A cable (with E-marker)

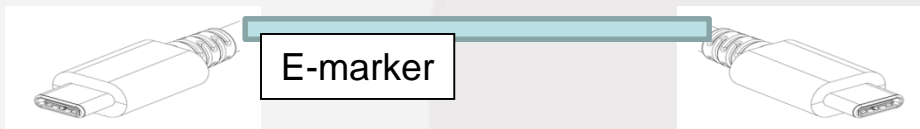

Captive Cable Example



New feature for Type-C

Using CC pins, a DFP can advertise to its port partner (UFP) the amount of current it can supply:

- Default values from USB 2.0 / USB3.1
 - 1.5 A – Medium current mode
 - 3.0 A – High current mode
- Allows the power source to manage the current it provides (e.g reduce current when own battery is low)
- Eliminates need to use D+/D- pins to advertise supply, as used in BC 1.2

Without Power Delivery, USB Type-C has some limitations:

- Can deliver up to 15W, cannot exceed 5.5V
- Cannot do any alternate modes (USB data only)
- DFP (host) must provide power
- UFP (device) cannot provide power

USB Power Delivery Contract Example

Scope Capture w/ TPS65982 Firmware (One DFP as a Dock & One UFP as a Notebook)

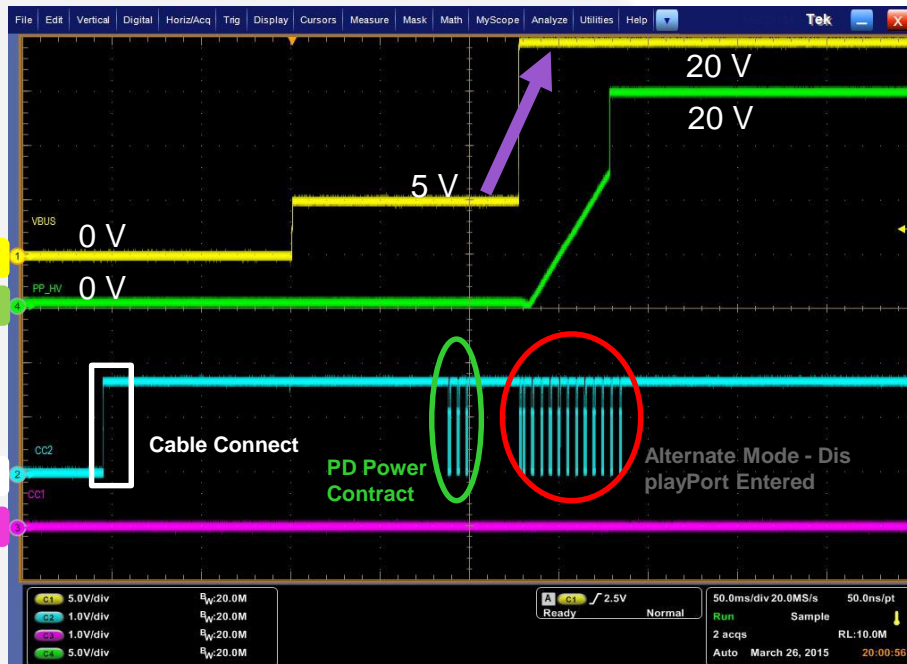

- DFP & UFP establish a PD power contract
- DFP send source capabilities and UFP will send back sink capabilities
- PD contract established
VBUS changes to 20V
- DFP enters Discovery Mode

USB Power Delivery Contract Example Protocol Information

Ellisys Analyzer w/ TPS65982 Firmware
(One DFP as a Dock & One UFP as a Notebook)

Source Capabilities (Fixed 5V 3A, Fixed 20V 3A)	OUT
Source Capabilities packet (Fixed 5V 3A, Fixed 20V 3A)	OUT
GoodCrc packet	IN
Request (Object 2 = Fixed 20V 3A, Requested 3A, Maximum 3A) > Accepted	IN
Request (Object 2 = Fixed 20V 3A, Requested 3A, Maximum 3A)	IN
Accept	OUT
PSRdy	OUT
PsRdy packet	OUT
GoodCrc packet	IN
Discover Identity > Ack (Undefined)	OUT
Discover Identity	OUT
Discover Identity Ack (Undefined)	IN
Discover SVIDs > Ack (0xFF01)	OUT
Discover SVIDs	OUT
Discover SVIDs Ack (0xFF01)	IN
Discover Modes (SVID = 0xFF01) > Ack (0x001C0045)	OUT
Discover Modes (SVID = 0xFF01)	OUT
Discover Modes (SVID = 0xFF01) Ack (0x001C0045)	IN
Enter Mode (SVID = 0xFF01, Mode = 1) > Ack	OUT
Enter Mode (SVID = 0xFF01, Mode = 1)	OUT
Enter Mode (SVID = 0xFF01, Mode = 1) Ack	IN
SVID Specific Command (0x10) > Ack	OUT
SVID Specific Command (0x10)	OUT
SVID Specific Command (0x10) Ack	IN
SVID Specific Command (0x11) > Ack	OUT
SVID Specific Command (0x11)	OUT
SVID Specific Command (0x11) Ack	IN



PDO (Provide data object)

1	Fixed Supply PDO	2	Fixed Supply PDO
◆ M 3 A m Current	1 A	◆ Maximum Current	3 A
◆ Voltage	5 V	◆ Voltage	20 V
◆ Peak Current	Ioc	◆ Peak Current	Ioc
◆ Type-C DRP	No	◆ Type-C DRP	No
◆ USB Communication Capable	No	◆ USB Communication Capable	No
◆ Externally Powered	No	◆ Externally Powered	No
◆ Usb Suspend Supported	No	◆ Usb Suspend Supported	No
◆ Dual Role Power	No	◆ Dual Role Power	No

USB-C and USB-PD Links

For more information on the USB-C and USB-PD standards please review the [USB-IF's Universal Serial Bus Revision 3.1 Specification](#)

For more information on TI's USB-C and PD solutions please visit the following links:

- [USB Type-C Overview](#)
- [USB Power Delivery Overview](#)
- If you have any questions or need any further assistance choosing the right USB-C and PD device for your system please visit the [USB E2E Forum](#)



SERIAL
新擘集團

TI USB Type-C solution

Your Integral Component to Success



SERIAL
新曄集團

USB-C Controllers & Signal Conditioners

Your Integral Component to Success

USB Type-C and PD Ecosystem

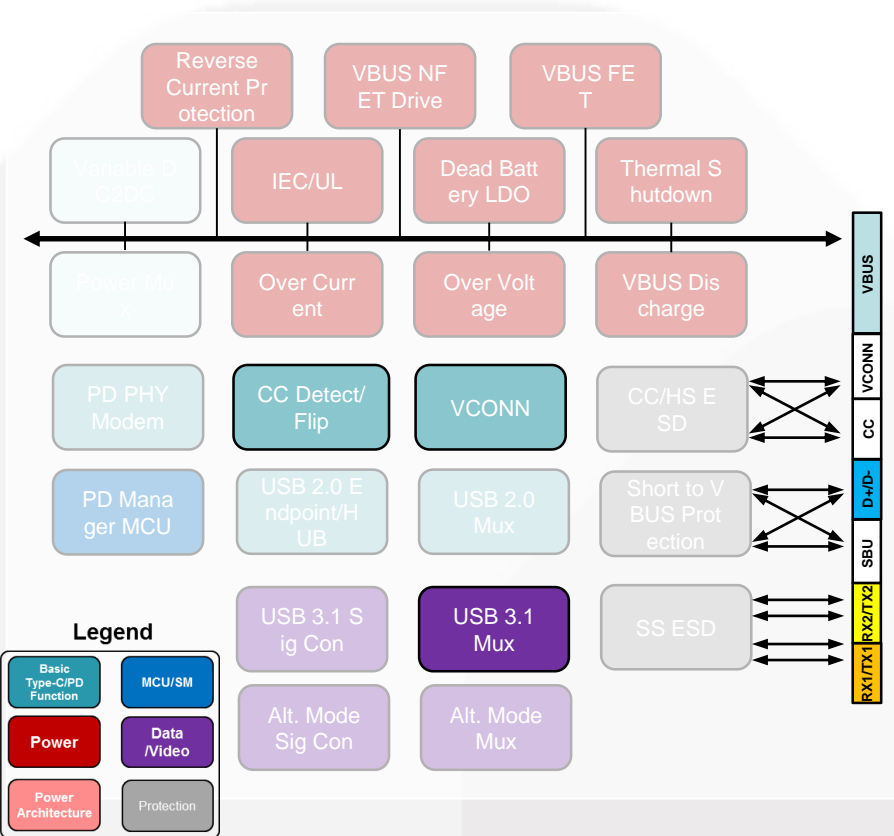

HD3SS2522 USB Type C Super Speed MUX with DFP Controller

**Compliant to USB Type C Specification 1.1
Provides Configurable Channel Logic**

- Attach USB Port Detection
- Cable Orientation Detection
- Type-C Current Mode (Default, Mid, High)

Supports Data Rates up to 10Gbps with Wide -3dB BW of 8GHz

Excellent Dynamic Characteristics at 2.5GHz

- Crosstalk = -39dB
- Off Isolation = -22dB
- Insertion Loss = -1.2dB
- Return Loss = -12dB

Low Active (2mW) and Standby Power (50µW) Consumption

Provides automatic determination and configuration of USB SS mux for cable orientation

Flexibility for many different applications

Provides IOs to support 5V VCONN sourcing

USB Type-C and PD Ecosystem

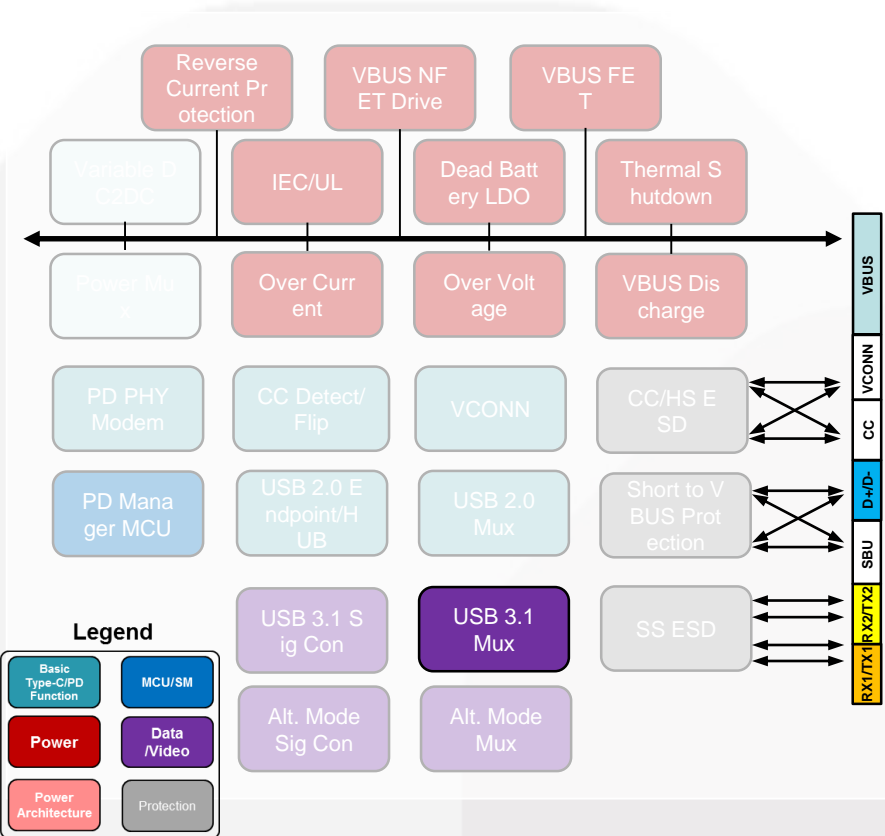

HD3SS3212 USB 3.1 SS High Performance Differential Switch

- Provides MUX/DEMUX solution for USB Type-C ecosystem for USB3 and USB3.1
- 2mW active and 20uW shutdown power Typ
- Wide -3dB BW of over 10GHz
- Excellent Dynamic Characteristics (at 5GHz)
 - Crosstalk = -35dB
 - Off Isolation = -19dB
 - Insertion Loss = -1.5dB
 - Return Loss = -11dB
- Single Supply VCC of 3.3V ±10%
- Dynamic Common Mode Tracking
- 2.5mmx4.5mm QFN Package (p2p with industry)
- Commercial Temperature Range of 0 to 70°C
- Industrial Temperature Range of -40°C to 85°C

USB Type-C and PD Ecosystem

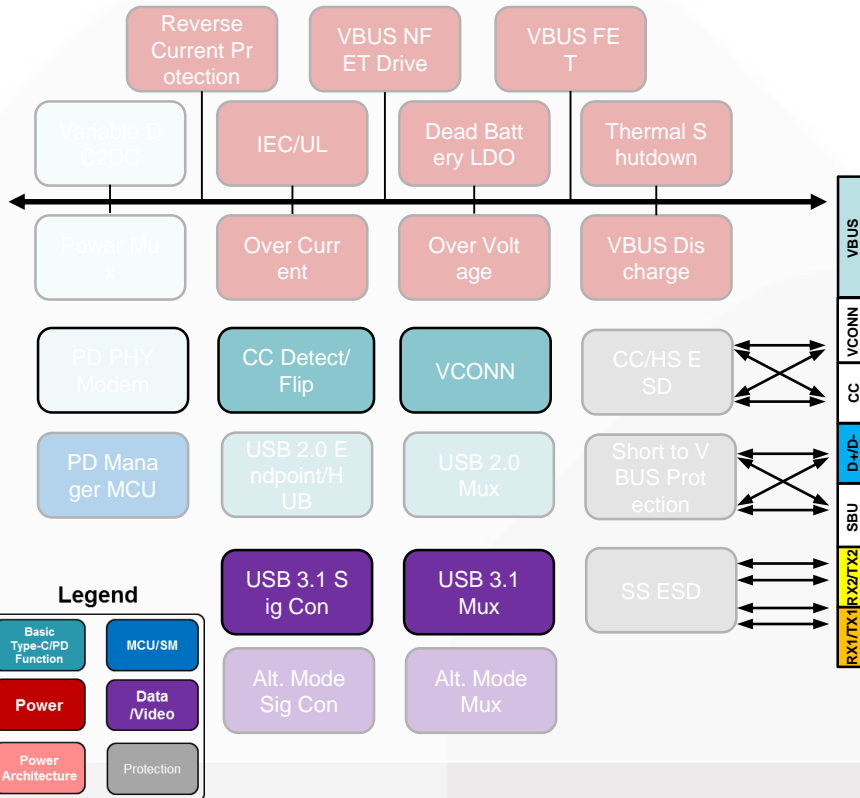

HD3SS3220 Type-C MUX with DRP Port Controller

Optimized for Mobile Applications and Compatible to USB TypeC Specifications 1.1

2:1 switching for USB 3.1 SS pairs

Mode configuration (DFP, UFP, DRP)

- Host Only, Device Only, Dual Role Port
- I2C and GPIO for Configuration

Channel Configuration (CC)

- Attach of USB Port Detection
- Cable Orientation Detection
- Role Detection
- Type-C Current Mode (Default, Mid, High)

ID Emulation

Supports VCONN

Supply Voltage 3.3V & 5V

Low Standby Current Consumption

Industrial Temperature Range -40° C to 85° C

Package: 30pin VQFN 2.5mm x 4.5mm

USB Type-C and PD Ecosystem

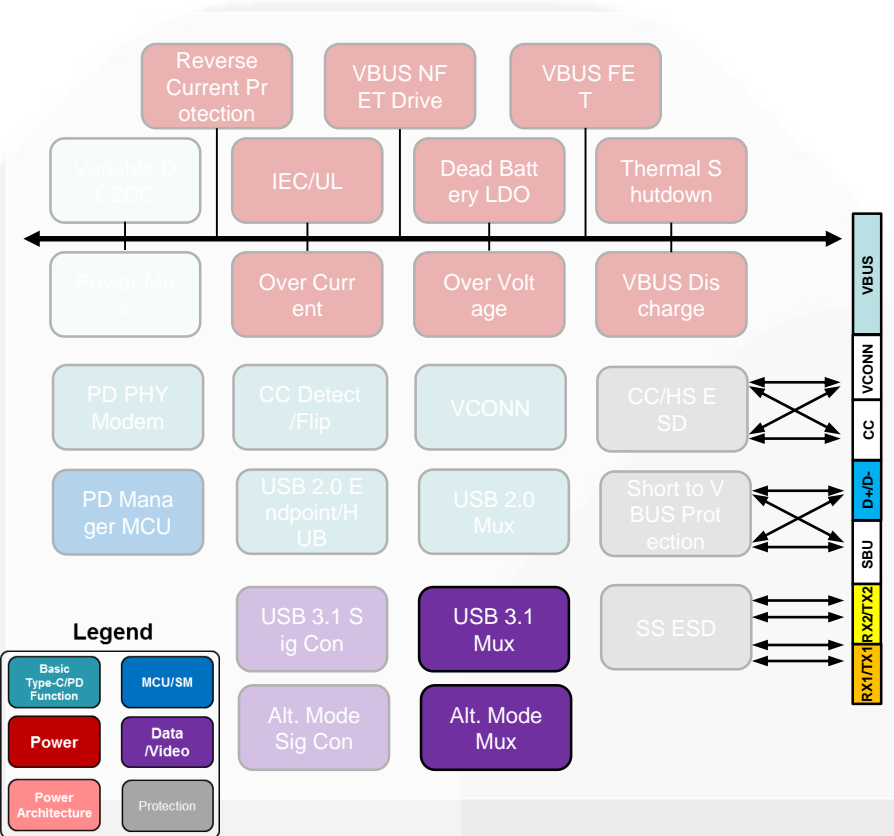

HD3SS460 4 x 6 Channels USB Type-C Alternate Mode MUX

Compatible to USB TypeC Specifications 1.0 X-point mux for USB Type-C with Alt Modes

- Switching between 2 Ln DP + USBSS or 4 Ln DP
- Switching for SBU pins

Low power with 2mW active, 20uW shutdown -3dB BW of over 5GHz

Excellent dynamic characteristics (at 2.5GHz)

- Off isolation = -25dB
- Insertion loss = -1.6dB
- Return loss = -11dB

Single supply VCC of 3.3V ±10%

Available in both Commercial Industrial Temperature 28 pin QFN package 3.5x5.5mm & 0.5mm pitch

USB Type-C and PD Ecosystem

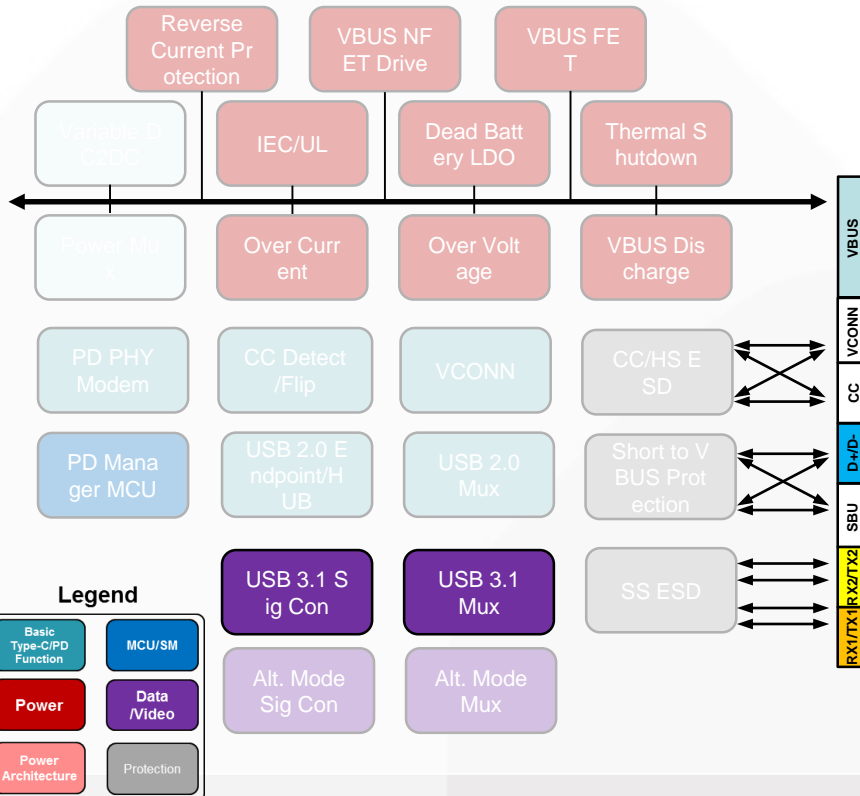

TUSB542

USB Type-C 5Gbps Redriver 2:1 MUX

- Provides USB 3.1 Gen 1 5Gbps Super Speed (SS) 2:1 Mux for a Type-C Port
- Supports USB Type-C Cable and Connector Spec 1.1
- Ultra Low-Power Architecture
 - Active: 100mA, U2/U3: 12mA, NC: 4mA, Shutdown: 20µA
- Selectable Equalization, De-Emphasis, and Output Swing
- Automatic LFPS De-Emphasis Control for USB 3.1 Compliance
- Integrated Termination
- RX-detect function
- Signal Monitoring for Power Management
- No Host/Device Side Requirement
- Single Supply Voltage 1.8V ±10%
- Package: 18 pin QFN 2mm x 2.4 mm pitch:0.35mm
- Operating temperature range: 0° C to 70° C (commercial) and -40° C to 85° C (industrial)

USB Type-C and PD Ecosystem

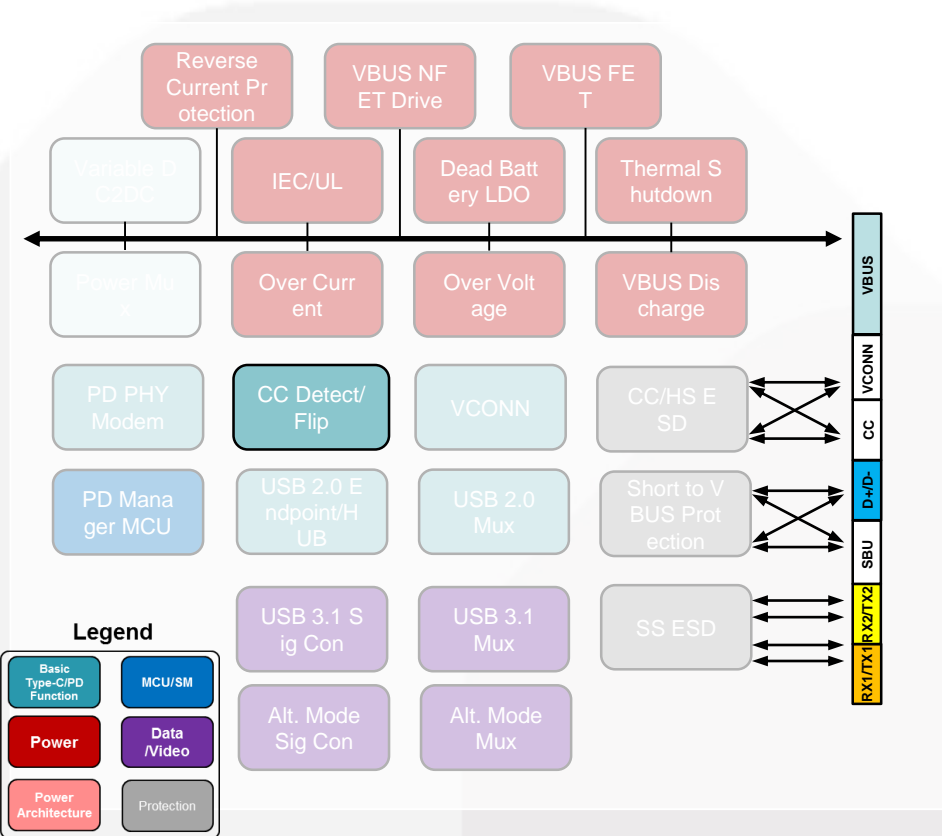

TUSB32x Type-C CC and Mode Controller

Optimized for Mobile Applications and Compatible to USB Type-C Specification 1.1

Mode configuration (DFP, UFP, DRP)

- Host Only,
- Device Only,
- Dual Role Port
- I2C and GPIO for Configuration

Channel Configuration (CC)

- Attach of USB Port Detection
- Cable Orientation Detection
- Role Detection
- Type-C Current Mode (Default, Mid, High)

Support ID Emulation and VBUS detection

Flexible Supply Voltage 2.7-5V

Low Active Standby Current Consumption

Industrial Temperature Range

1.6x1.6mm QFN package

USB Type-C and PD Ecosystem

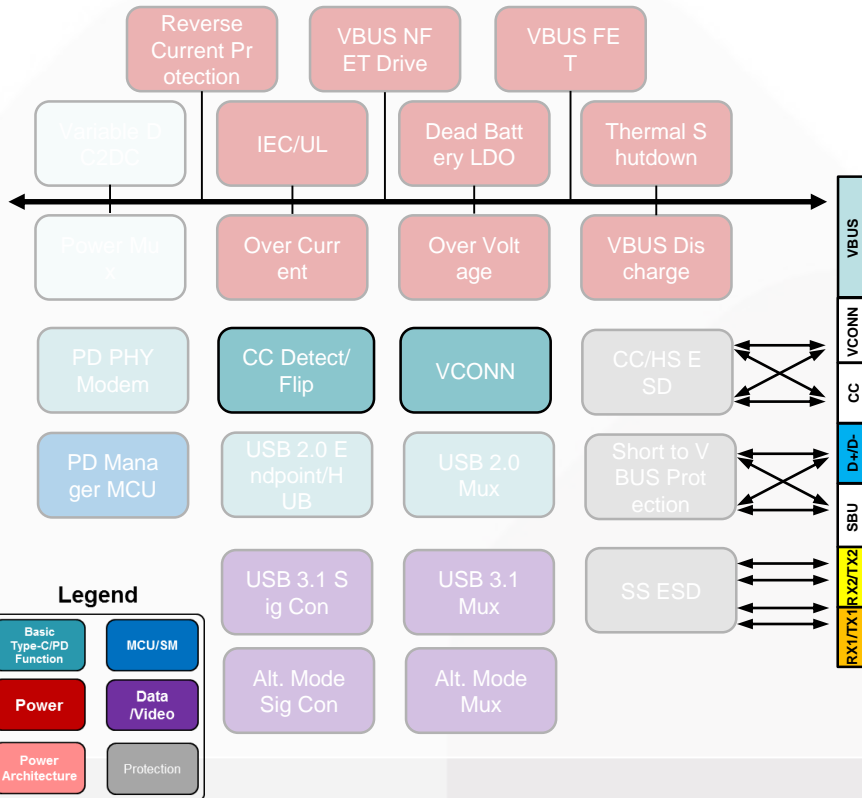

TUSB321 / TUSB322

Type-C CC Logic, Port Control and VCONN Switch

Optimized for Mobile Applications and Compatible to USB Type-C Specification 1.1

Mode configuration (DFP, UFP, DRP)

- Host Only,
- Device Only,
- Dual Role Port
- I2C (TUSB322 only) and GPIO for Configuration

Channel Configuration (CC)

- Attach of USB Port Detection
- Cable Orientation Detection
- Role Detection
- Type-C Current Mode (Default, Mid, High)

ID Emulation and VBUS detection
VCONN support, Supply Voltage 4.5-5.5V
Low Active Standby Current Consumption
Industrial Temperature Range, 1.6x1.6mm QFN package



SERIAL
新曄集團

USB-C/PD Controllers (Fully Integrated)

Your Integral Component to Success

USB Type-C and PD Ecosystem

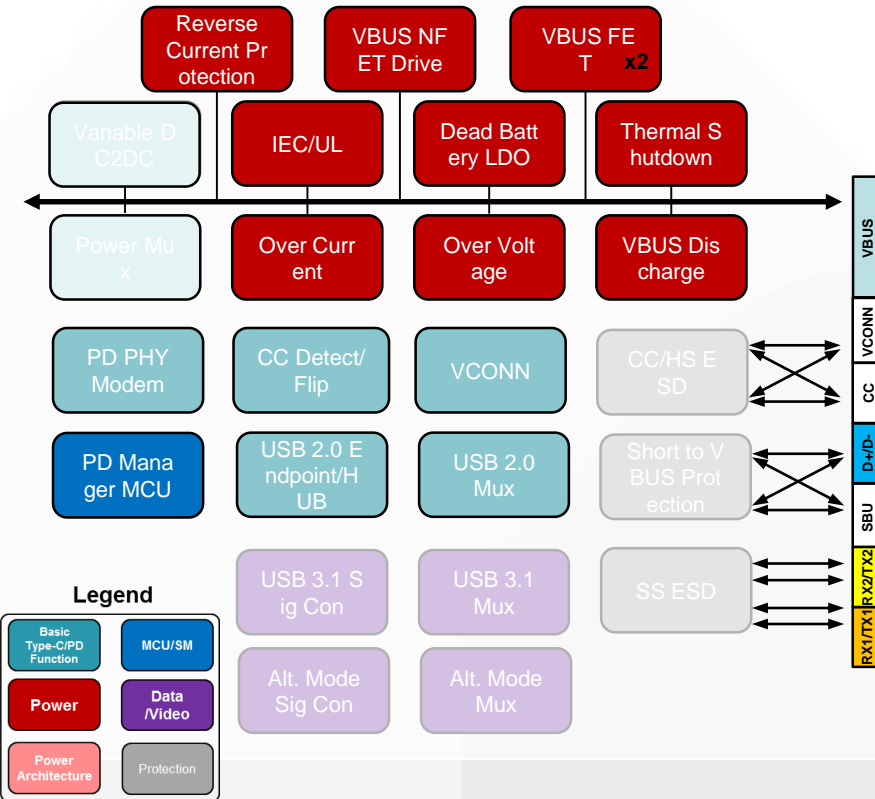

TPS65982 - USB Type-C Port Power Switch with USB-PD Controller & HS Mux

- Supports all Type-C High Current Modes**
- Integrated Port Power Switches up to 20V @ 3A
 - Supports optional bi-directional external power NMOS FETs
 - Integrated Dead Battery LDO
- Fully compliant USB PD Baseband modem per USB PD2.x**
- BMC encoder/decoder, Physical Layer with CRC
 - No external MCU needed includes Port Policy Manager
- Performs all CC pin functions w Integrated Vconn**
- Cable Detection and Cable Orientation
 - No external Vconn components needed
- Integrated HS Mux & Alternate Mode Support**
- CC/2, SBU1/2, USB TP/TN, USBBP/BN
 - USB 2.0 Endpoint for Billboard & Flash Update
 - Display Port, Thunderbolt™, PDIO, QuickSwap, MHL
- Flexible system interfaces**
- I2C Slave/Master, SPI, Simple connection to HD3SS460 SS Mux for Display Port/USB3.0
- Easy to use 6 x 6 mm, non HDI uBGA ZQZ 96pin, 0.5mm pitch**

USB Type-C and PD Ecosystem

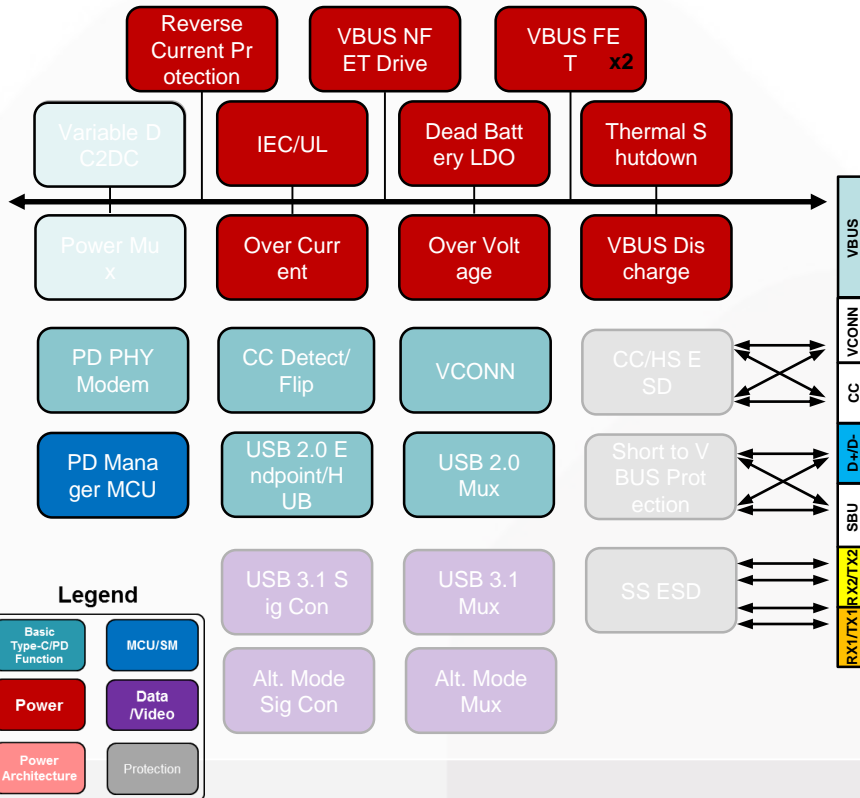

TPS65983 - Thunderbolt™ 3 USB Type-C and USB-PD Port Controller

- **USB Power Delivery (PD) Controller**
 - Mode Configuration for Source (Host), Sink (Device), or Source-Sink.
- **USB Type-C Specification Compliant**
 - Cable Orientation and Role Detection
- **Port Power Switch**
 - Supports 100W (20V, 5A), 60W (20V, 3A), and 15W (5V, 3A) of power
 - Meets USB Type-C Slew Rate Control, Hard Reset Support requirements
 - Integrated VCONN
 - Overcurrent, overvoltage, reverse current, and thermal protection
- **Port Data Multiplexer**
 - Sideband Use Data for Alternate Mode Support
 - DisplayPort, Thunderbolt™, etc.
- **Power Management**
 - 3.3V LDO Output for Dead Battery Support
 - Supports 100W (20V, 5A) External Power Path
- **UL 2367 and IEC 6950 Certified**
- **6x6mm, 96 Pin BGA MicroStar Junior Package**

USB Type-C and PD Ecosystem

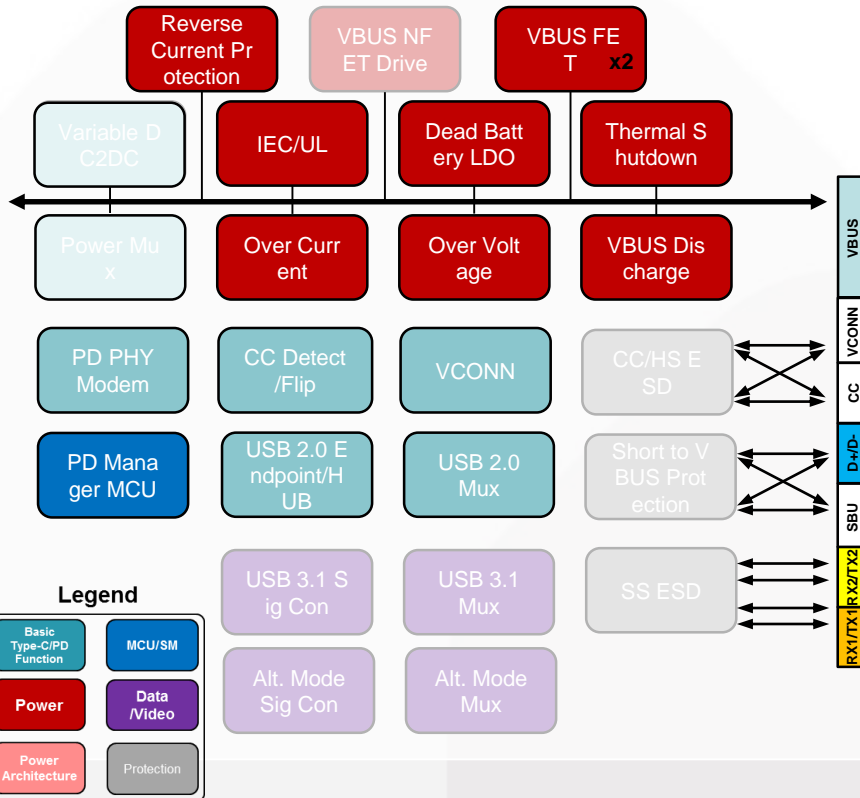

TPS65986 - USB Type-C Port Power Switch with USB-PD Controller

- **USB Power Delivery (PD) Controller**
 - Mode Configuration for Source (Host), Sink (Device), or Source-Sink.
- **USB Type-C Specification Compliant**
 - Cable Orientation and Role Detection
- **Port Power Switch**
 - Supports 60W (20V, 3A), and 15W (5V, 3A) of power
 - Slew Rate Control
 - Overcurrent, overvoltage, reverse current, and thermal protection
 - Hard Reset Support
- **Port Data Multiplexer**
 - Sideband Use Data for Alternate Mode Support
 - DisplayPort, etc.
- **Power Management**
 - 3.3V LDO Output for Dead Battery Support
- **UL 2367 and IEC 6950 Certified**
- **6x6mm, 96 Pin BGA MicroStar Junior Package**

USB Type-C and PD Ecosystem

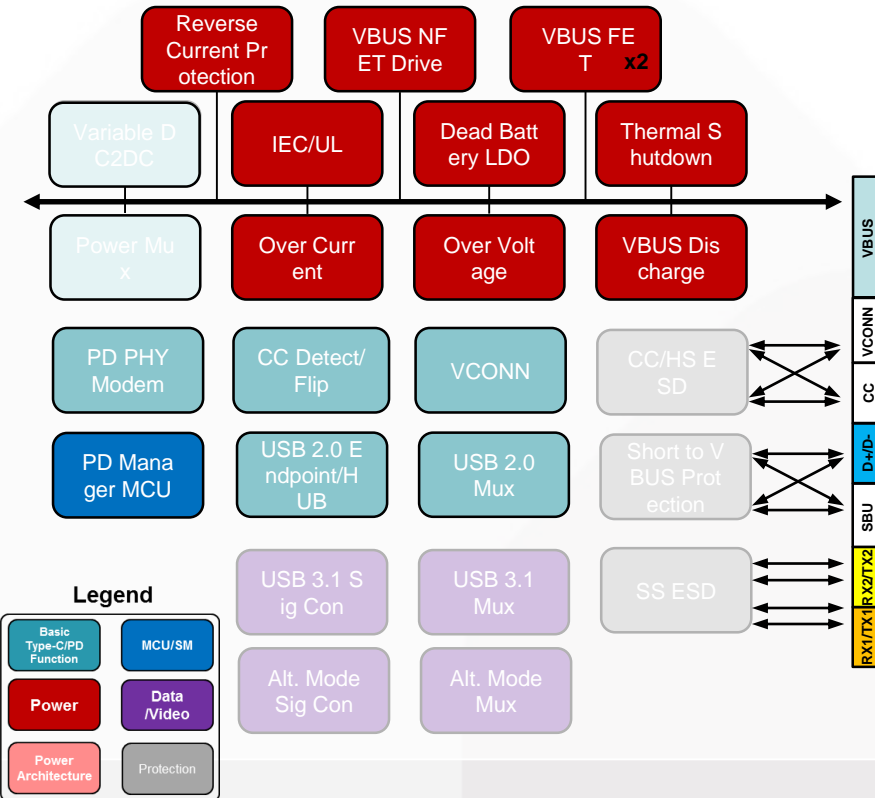

TPS65981/Q1 - USB Type-C Port Power Switch with USB-PD Controller & HS Mux

Supports all Type-C High Current Modes

- Integrated Port Power Switches up to 20V @ 3A
- Supports bi-directional external power NMOS FETs

Fully compliant USB PD Baseband modem per USB PD2.x

- BMC encoder/decoder
- Physical Layer with CRC
- Policy and Policy Engine

Performs all CC pin functions

- Cable Detection and Cable Orientation

Integrated HS Mux & USB 2.0 Endpoint

- CC/2, SBU1/2, USB TP/TN, USBBP/BN
- Support for Guest Port Protocols
 - Display Port

Flexible system interfaces

- I2C Slave/Master, SPI, Simple connection to HD3SS460 SS Mux for Display Port/USB3.0

Easy to use 8x8mm 56pin QFN

Commercial (-40 to 85), Industrial (-40 to 105), and Automotive (-40 to 125) temp ranges

Easy to use 8x8mm 56pin QFN (Q1 will have Wettable Flanks)



SERIAL
新曄集團

USB-C & USB-C/PD Controllers

Your Integral Component to Success

USB Type-C and PD Ecosystem

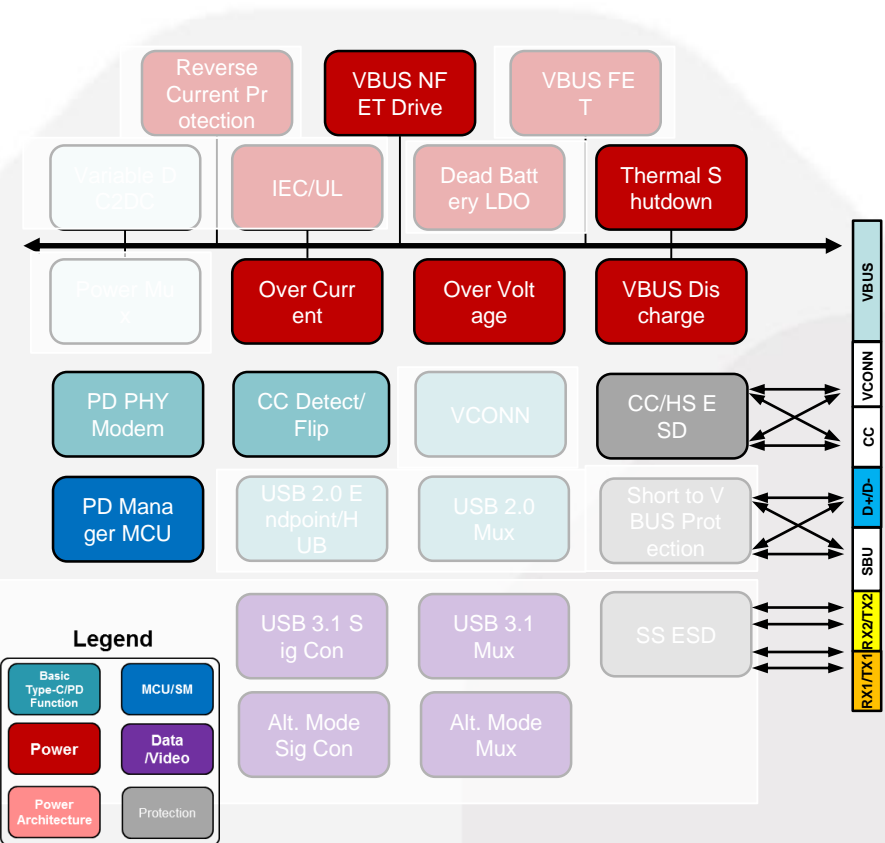

TPS25740/40A/40B - USB Type-C Port Power Switch with USB PD controller

No external MCU need, No Firmware need, integrated DFP solution

USB Type-C DFP Interface

- PD 2.0 physical layer, policy engine, device policy manager
- 12 pin-selectable peak power advertisements (15W – 100W)
- Advertises up to 3 voltages
 - 5V, 12V, 20V (TPS25740)
 - 5V, 9V, 15V (TPS25740A)
 - 5V, 9V, 15V, 20V (TPS25740B)
- Connector Attach/Detach Detection
- V_{BUS} Application
- Declares the system is not USB data capable

<10 uA (typ) Operating Current with Nothing Attached

Integrated N-ch MOSFET gate driver and discharge (ABS MAX 30V)

No need for LDO where 3.3V/5V is not available

CC1 and CC2 +/-8 kV Contact and +/-15 kV Air Discharge ESD Rating (IEC 61000-4-2)

Offered in 4x4, 24pin QFN Package

USB Type-C Ecosystem

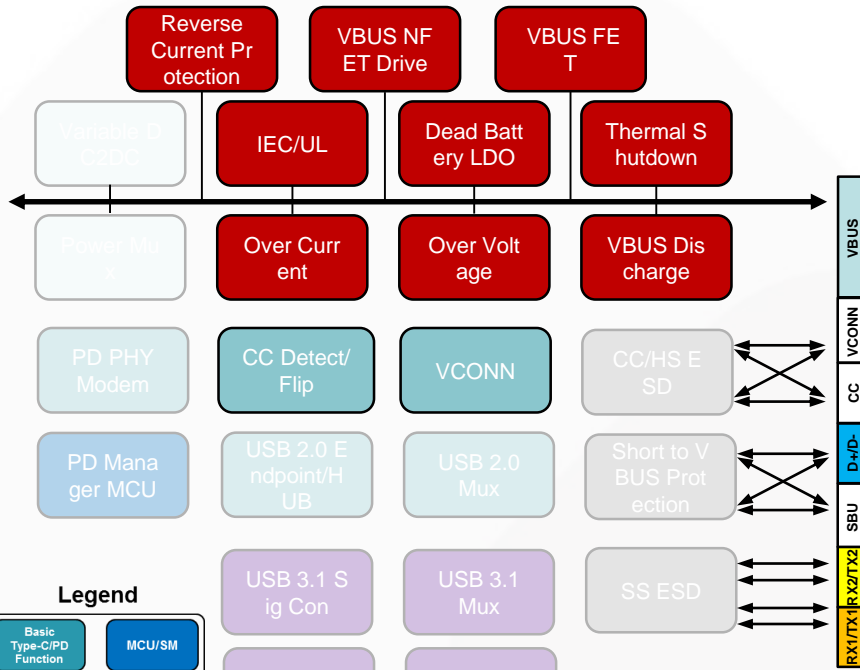

Legend

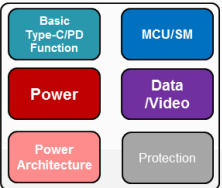

TPS25810 - USB Type-C Port Power Switch

USB Type-C DFP Interface (15W)

- Connector Attach/Detach Detection
- STD/1.5A/3A Capability Advertisement on CC Line
- V_{BUS} Application
- V_{CONN} Application to Active Cable

<0.7 uA (typ) Operating Current with Nothing Attached

Dedicated Supply for Charging, VCONN and Device Power

Integrated 34 mΩ (typ) High-Side MOSFET

Selectable 3.34 A/1.67 A OUT Current Limit with +/- 7.5% Accuracy

Load Detection to Enable Port Power Management

CC1 and CC2 +/-8 kV Contact and +/-15 kV Air Discharge ESD Rating (IEC 61000-4-2)

Offered in 3x4, 20-pin QFN Package

PCB Size Comparison for 15W DFP Solution

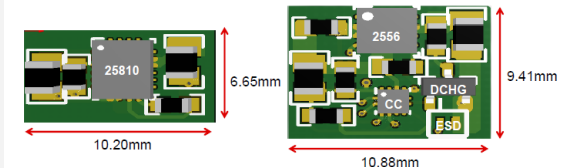

TPS25810 Solution PCB size : 67.8 mm²

CC logic device FUSB3301 + Power switch size: 102.4mm²

Saves 33.7%

Key differentiation vs. competition
TPS25810 vs. FUSB3301



SERIAL
新擘集團

USB-C Protection Devices

Your Integral Component to Success

Potential Failure Mechanisms

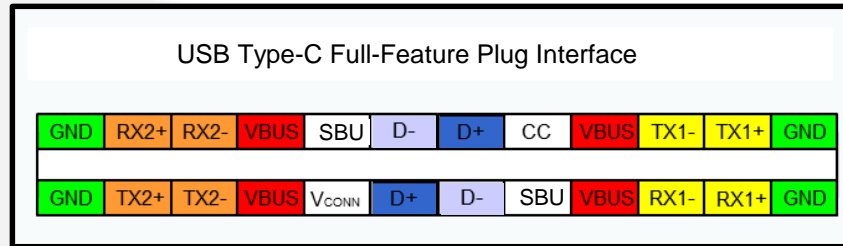
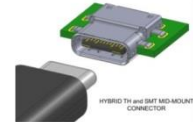

Figure 3-7 Reference Footprint for a USB Type-C Mid-Mount Dual-Row SMT Receptacle (Informative)



Figure 3-8 Reference Footprint for a USB Type-C Mid-Mount Hybrid Receptacle (Informative)



- Non-Complaint Adapter/Cable:
 - Adaptors from China put out VBUS 20V before PD negotiation. This can damage Type C ports designed for 5V only on VBUS, and CC if pulled up to 5V VBUS rail and VBUS switch fails as short.
 - Pull up at far end on C to C or C to A can cause CC lines to see 20V if the adapter is not design properly and pulls CC up to VBUS that starts at 20V
- Mechanical Twist
 - Pitch of the connector pins are small, mechanical twist can cause CC & SBU lines to short with VBUS
- Debris
 - Debris getting into the connector can cause CC & SBU lines to short with VBUS

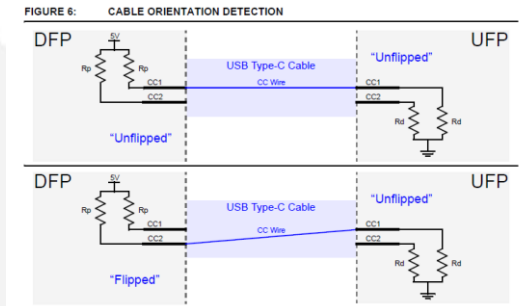

USB Type-C Ecosystem

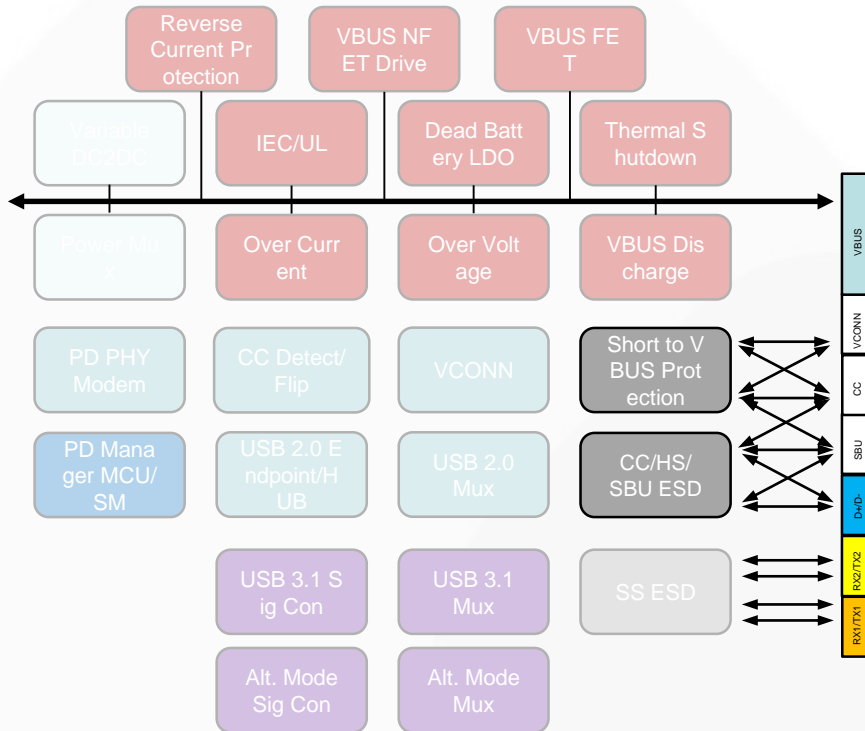

Functional Samples available Now!

TPD8S300 - USB Type-C CC, SBU, D+/D- protector for Short-to-VBUS & IEC ESD Events

One-Chip protection solution for USB Type-C Ports CC, SBU, and D+/D- lines

4-Channels of Short-to-VBUS Over Voltage Protection (CC1, CC2, SBU1, SBU2): 30V Tolerant OVP FETs

8-Channels of IEC 61000-4-2 ESD Protection (CC1, CC2, SBU1, SBU2, DP_T, DM_T, DP_B, DM_B)

- $\pm 8\text{kV}$ Contact, $\pm 15\text{kV}$ Air-Gap

CC1, CC2 FETs 600mA capable for passing VCONN power:

- Worst case 250mV drop across FETs @ 125C (500mA)

- Integrated R_D pull down on CC for Dead Battery Support
- 3mm x 3mm QFN Package Options
- 3.5mm x 3.5mm QFN Package Option for Q1 version

USB Type-C Ecosystem

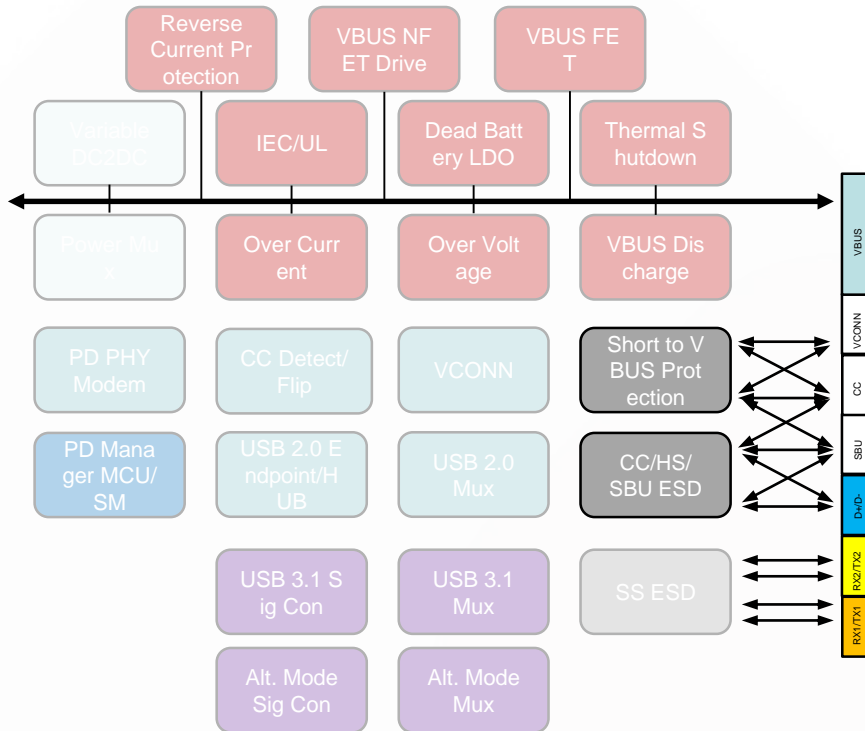

Functional Samples available Now!

TPD6S300 - USB Type-C CC, SBU, D+/D- protector for Short-to-VBUS & IEC ESD Events

One-Chip protection solution for USB Type-C Ports CC, SBU, and D+/D- lines

4-Channels of Short-to-VBUS Over Voltage Protection (CC1, CC2, SBU1, SBU2): 30V Tolerant OVP FETs

6-Channels of IEC 61000-4-2 ESD Protection (CC1, CC2, SBU1, SBU2, DP_T, DM_T, DP_B, DM_B)

- ±8kV Contact, ±15kV Air-Gap

CC1, CC2 FETs 600mA capable for passing VCONN power:

- Worst case 250mV drop across FETs @ 125C (500mA)

CC Dead Battery Resistors Integrated

- 3mm x 3mm QFN Package Options
- 3.5mm x 3.5mm QFN Package Option for Q1 version



SERIAL
新擘集團

USB-C Thermal Protection

Your Integral Component to Success

USB Thermal Protection

Heat dissipation is becoming increasingly difficult as chargers deliver more power. Chargers must protect internal circuitry, while also insuring external surfaces are safe to touch.

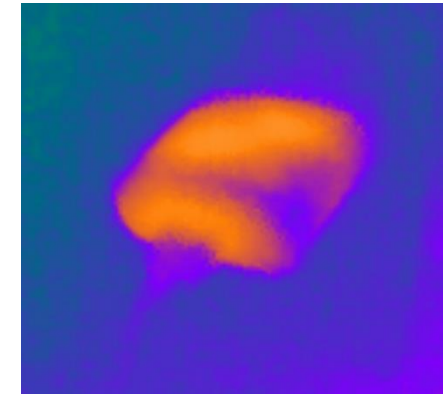

Precedence	Mode of Operation	Nominal Voltage	Maximum Current
Highest	USB PD	Up to 20 V	Up to 5 A
↑	USB Type-C current @ 3A	5 V	3 A
	USB Type-C current @ 1.5A	5 V	1.5 A
	USB BC1.2	5 V	Up to 1.5 A
	USB 3.1	5V	900 mA
Lowest	USB 2.0	5V	500 mA

Single Chip Over Temperature Protection

Temp Switch (Thermostat)

Automatically detects over temperature condition and issues Alert

- Compact Single Chip Solutions
- Guaranteed Accuracy to maximize charging without sacrificing safety.
 - No calibration
 - No sensitivity to humidity
- Optional Features:
 - Programmable Hysteresis
 - Analog Temperature Output
 - Dual Threshold Alerts
 - Window Comparator Alert.

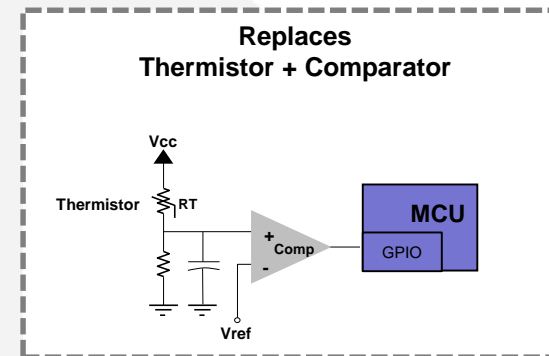
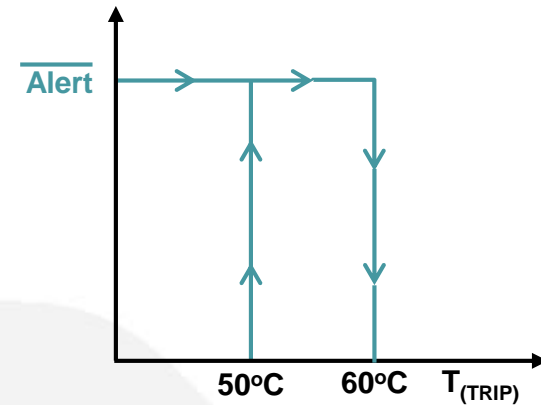
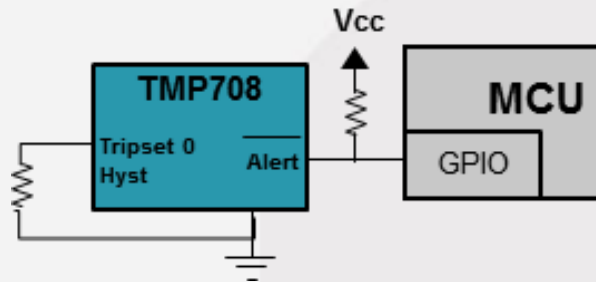

Featured Temperature Switches



Q100 Option Available
Q100 in Development

Multiple Programming Options Available

Factory Programmed

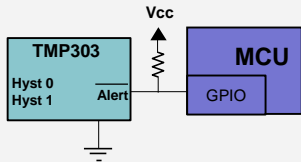

TMP303

- +/- 1C Accuracy
- Selectable Hysteresis:
 - 1/2/5/10°C
- Window Comparator
- 1.4V to 3.6V
- SOT-563 Package
 - 1.6 x 1.6mm Footprint

Pin Programmable

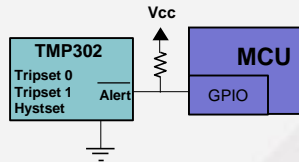

TMP302

- +/- 2C Accuracy
- Selectable Hysteresis:
 - 5°C / 10°C
- 1.4V to 3.6V
- SOT-563 Package
 - 1.6 x 1.6mm Footprint

Resistor Programmable

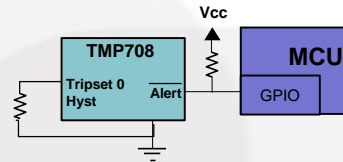

TMP708 / TMP709

- +/- 3C Accuracy
- Selectable Hysteresis:
 - 2°C / 10°C / 20°C
- 2.7V to 5.5V
- SOT-23

Resistor Programmable W/ Analog Temp

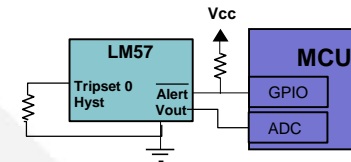

LM57

- +/- 1.5C Accuracy
- -40°C to 150°C
- Selectable Hysteresis:
 - 2.4V to 5.5V
- WSON & TSSOP

TMP300B

- 1.8V to 18V
- SOT-23 & SC70

LM56

- Dual Trip Point
- +/- 2C Accuracy
- -40°C to 150°C
- Selectable Hysteresis:
 - 5°C / 10°C
- 2.7V to 10V
- SOIC & VSSOP

Example Circuit

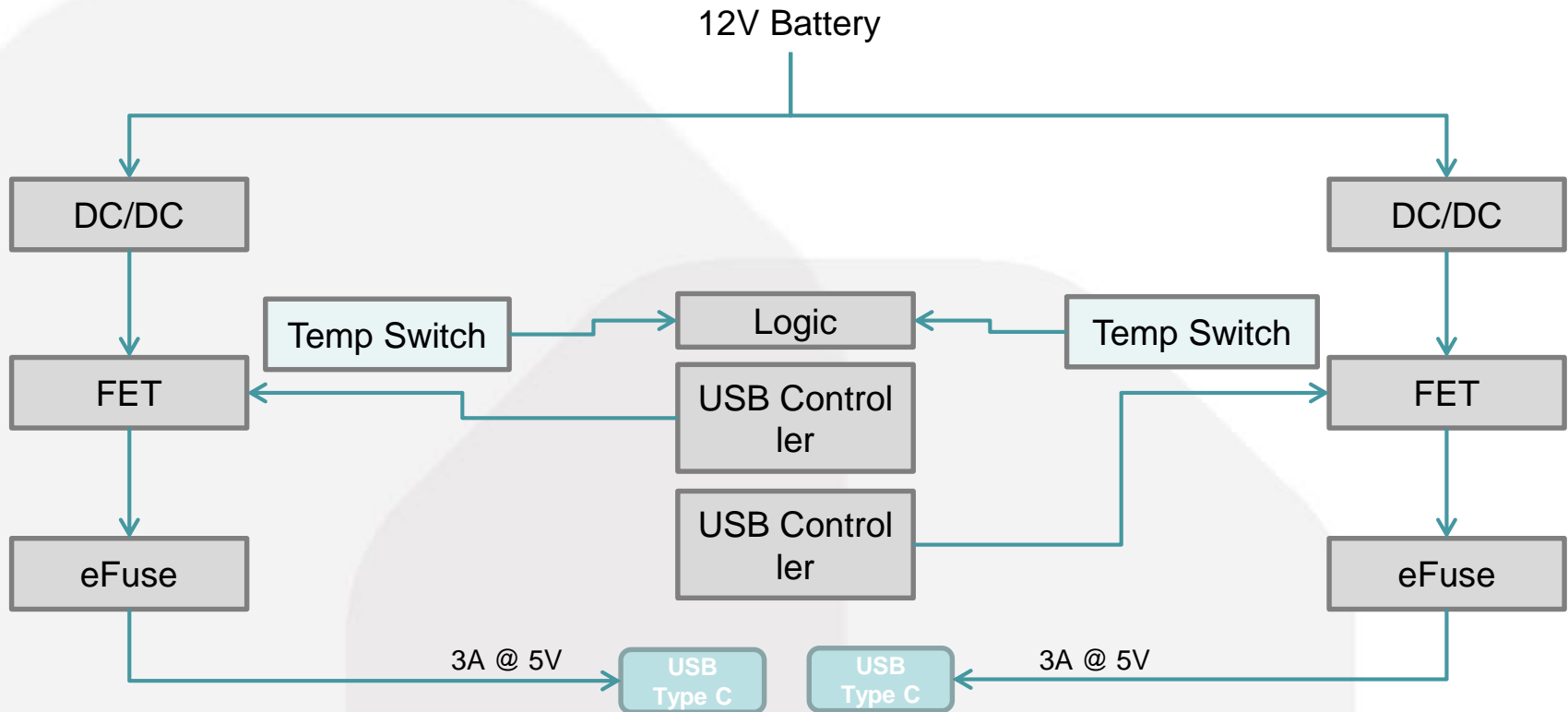

USB Type-C and PD Ecosystem

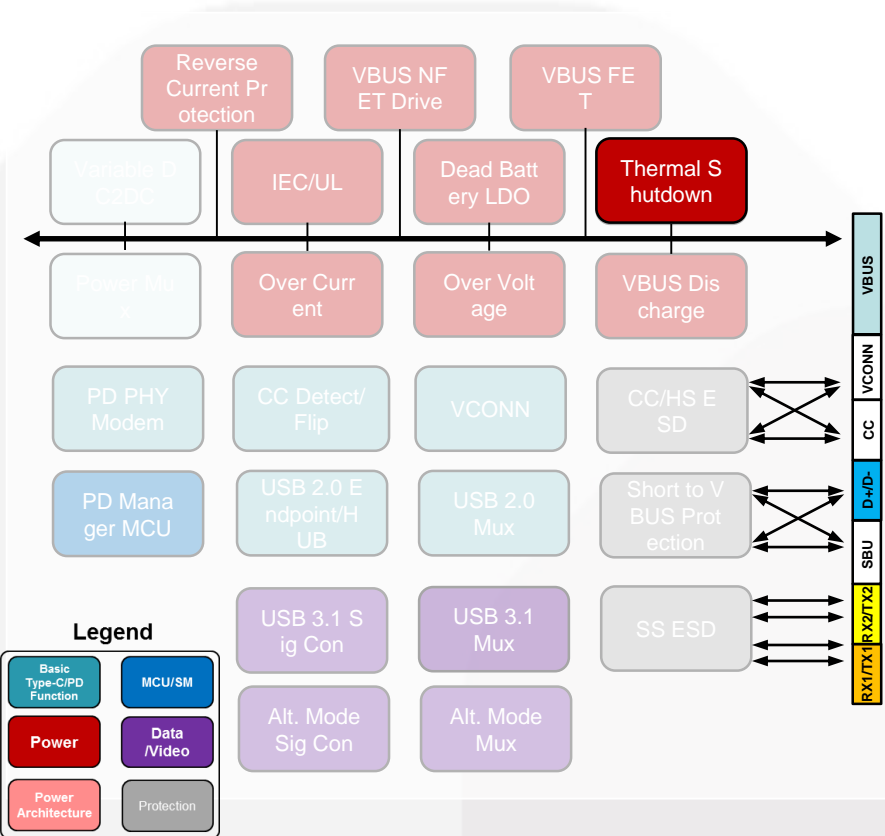

TMP302 Pin Programmable Thermostat / Temperature Switch

- Pin programmable thermal protection
- Selectable Hysteresis
-5°C / 10°C
- Compact SOT-563 Package
-1.6mm x 1.6mm footprint
- AEC-Q100 Option Available

Part #	Selectable Trip Points
TMP302A	50, 55, 60, 65
TMP302B	70, 75, 80, 85
TMP302C	90, 95, 100, 105
TMP302D	110, 115, 120, 125

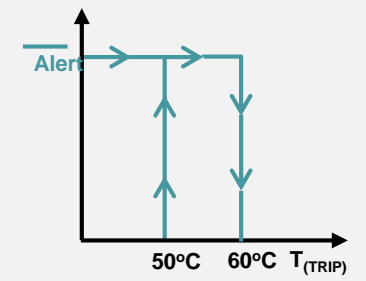

USB Type-C and PD Ecosystem

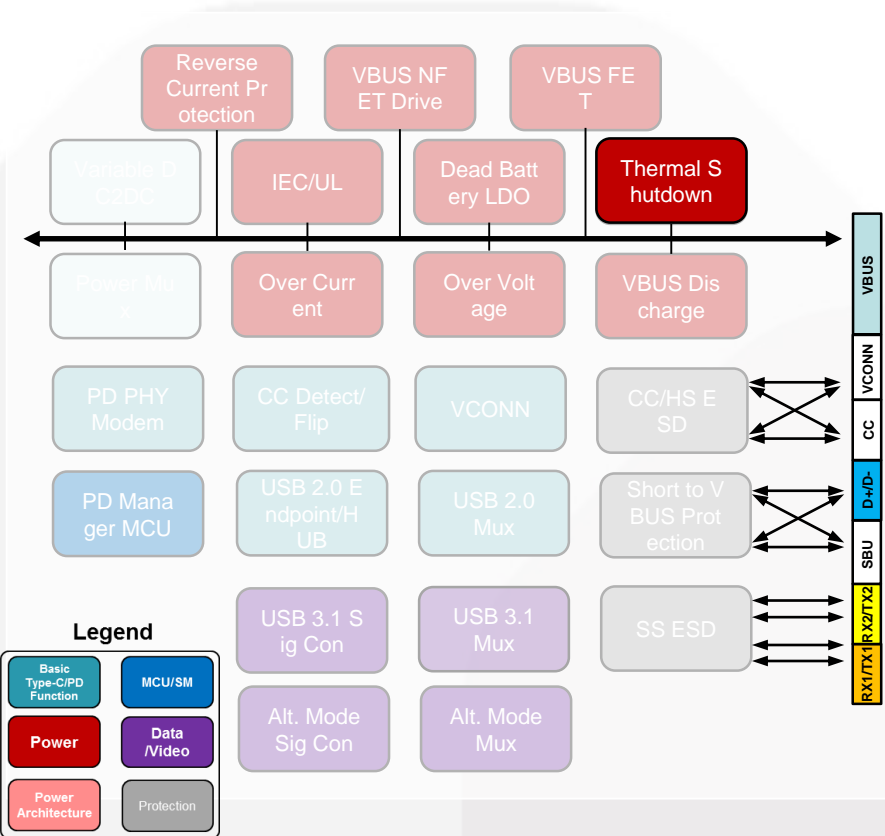

TMP708 Resistor Programmable Thermostat / Temperature Switch

Resistor programmable thermal protection
Selectable Hysteresis
 -2°C / 10°C / 30°C
SOT-23 Package
 -1.6mm x 1.6mm footprint
AEC-Q100 Option

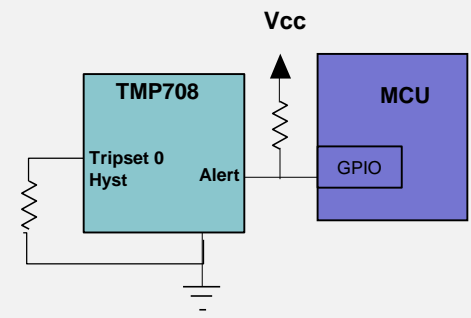

USB Type-C and PD Ecosystem

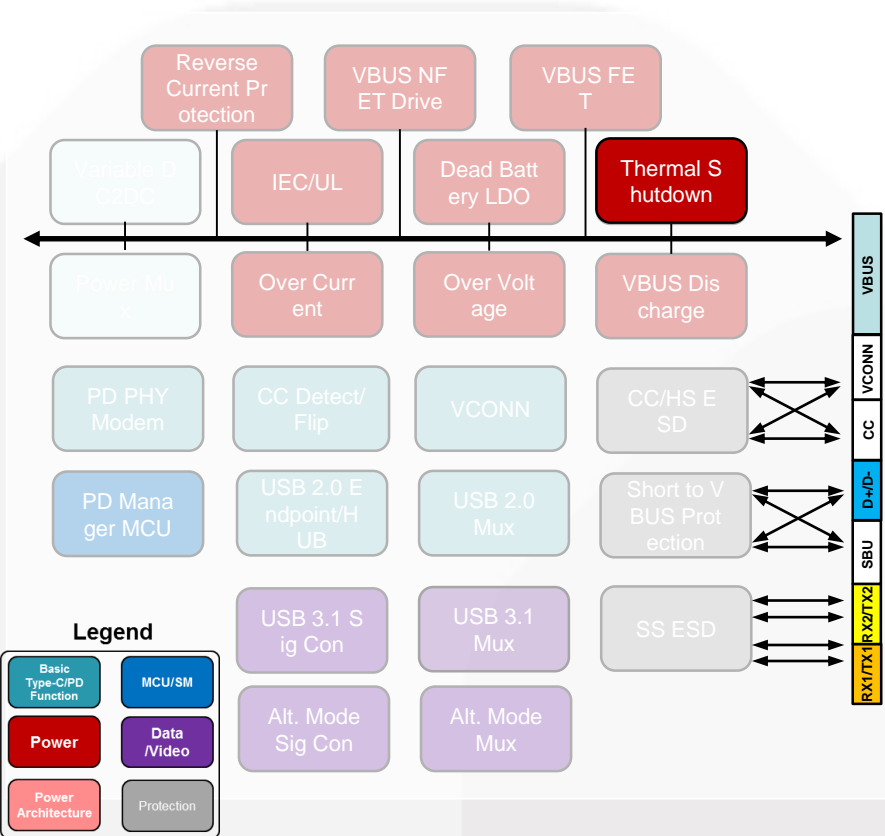

LM56

Dual Resistor Programmable Thermostat / Temperature S

Resistor programmable thermal protection

Selectable Hysteresis
-2°C / 10°C / 30°C

SOT-23 Package

-1.6mm x 1.6mm footprint

AEC-Q100 Option

- Dual Trip Point
- Accuracy: -40°C to 150°C
- Selectable Hysteresis:
 - 5°C / 10°C
- 2.7V to 10V
- SOIC & VSSOP

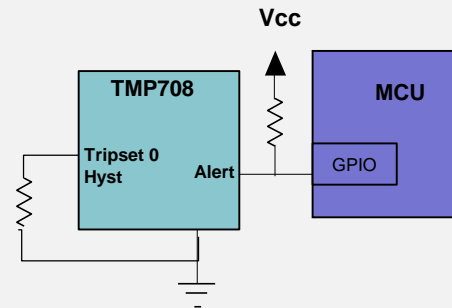

Additional IC Temperature Sensors Solutions

On Board Temperature Solutions

Local

Measures temp at device itself

Analog

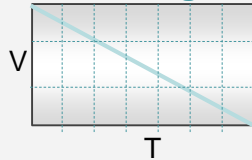

Digital

35°C

I2C
SPI
Pulse Count
UART

Remote

Multi-channel, Measures temp at external PN junction

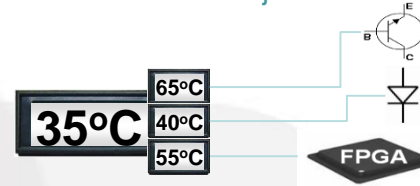

Switch/Thermostat

Simple Over Temperature Protection



Off Board Temperature Solutions

2 Pin (Point to Point)

Can be integrated into probes
Up to 2 meters

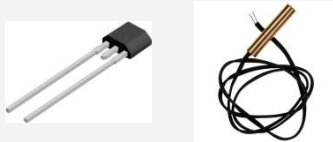

Daisy Chain

String multiple sensors in a single cable
Up to 300 meters



Non-Contact Thermopiles

Measures passive infrared energy to determine temperature of an object

35°C
Obj = 0°C



Other Featured Products:

	TMP103	TMP102	TMP108	LMT84
Interface	I2C	I2C w/ Alert	I2C w/ Window Alert	Analog
Supply Range	1.4V to 3.6V			1.5V to 5.5V
I2C Addresses Available	8		8	Analog
Accuracy: -10°C to +90°C -20°C to +85°C -10°C to 100°C -40°C to +125°C	2.0°C max 3.0°C max	2.0°C max 3.0°C max	0.75°C max 1.0°C max	2.7°C max
Resolution	8-Bit	12-Bit		-5.5 mV/°C
Quiescent Current (max)	3uA	10 uA	6uA	9uA
Shutdown Current	1uA			
Package Footprint	WCSP 0.8x0.8mm	SOT-563 1.6 x 1.6mm	WCSP 1.2x0.8mm	SC70 2.0x2.1mm



SERIAL
新曄集團

End Application Block Diagrams by Product

Your Integral Component to Success

TPS65986 USB Type C – Notebook – 3A, 2 Power Paths

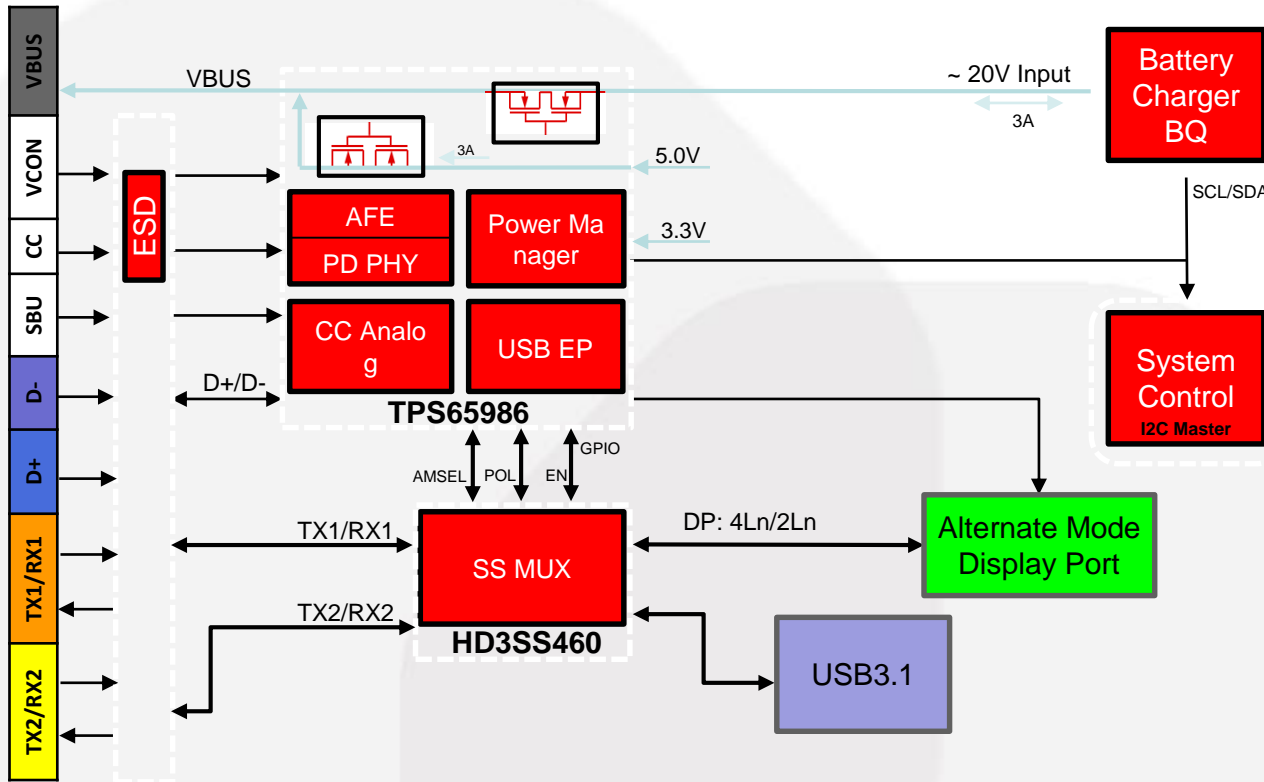

TPS65982 USB Type C – Notebook – 5A, 3 Power Paths

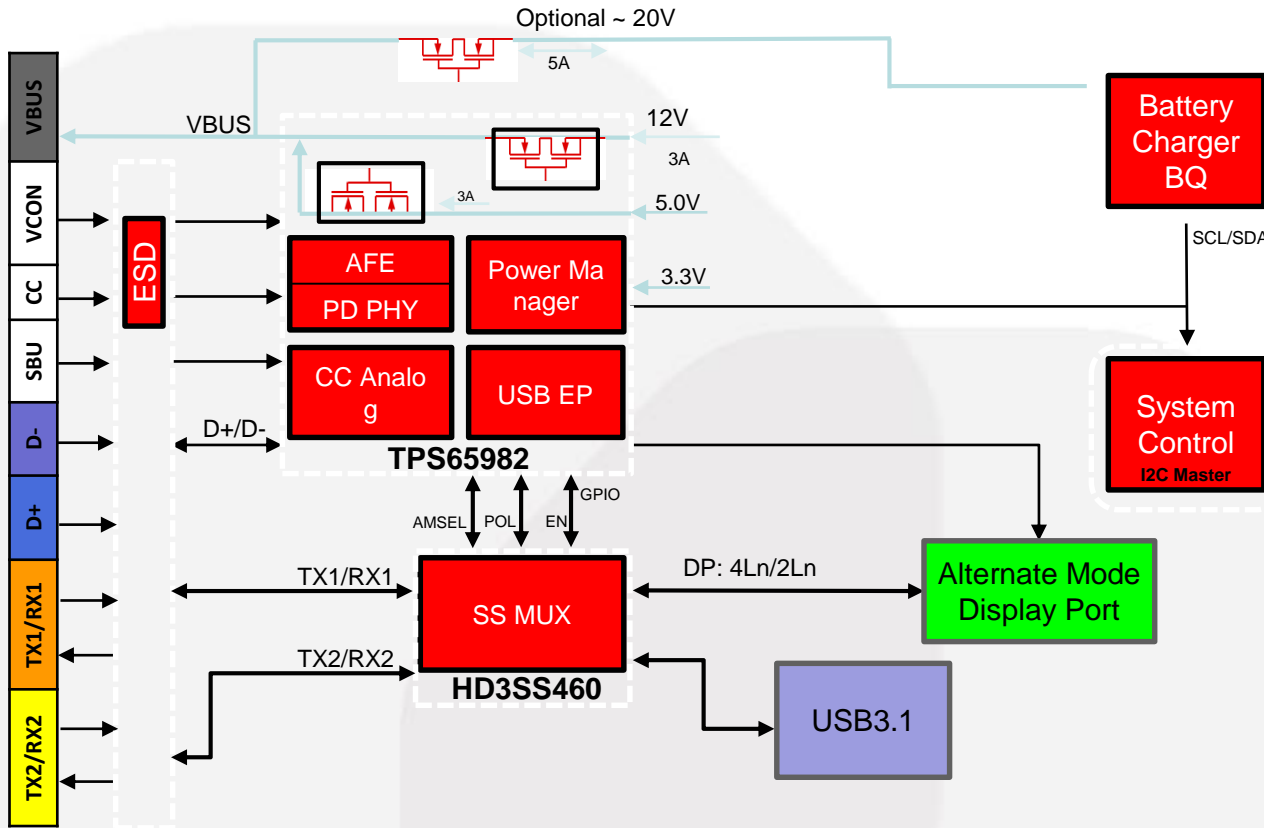

TPS65982 USB Type C Monitor – DP, USB3.1 & Charger

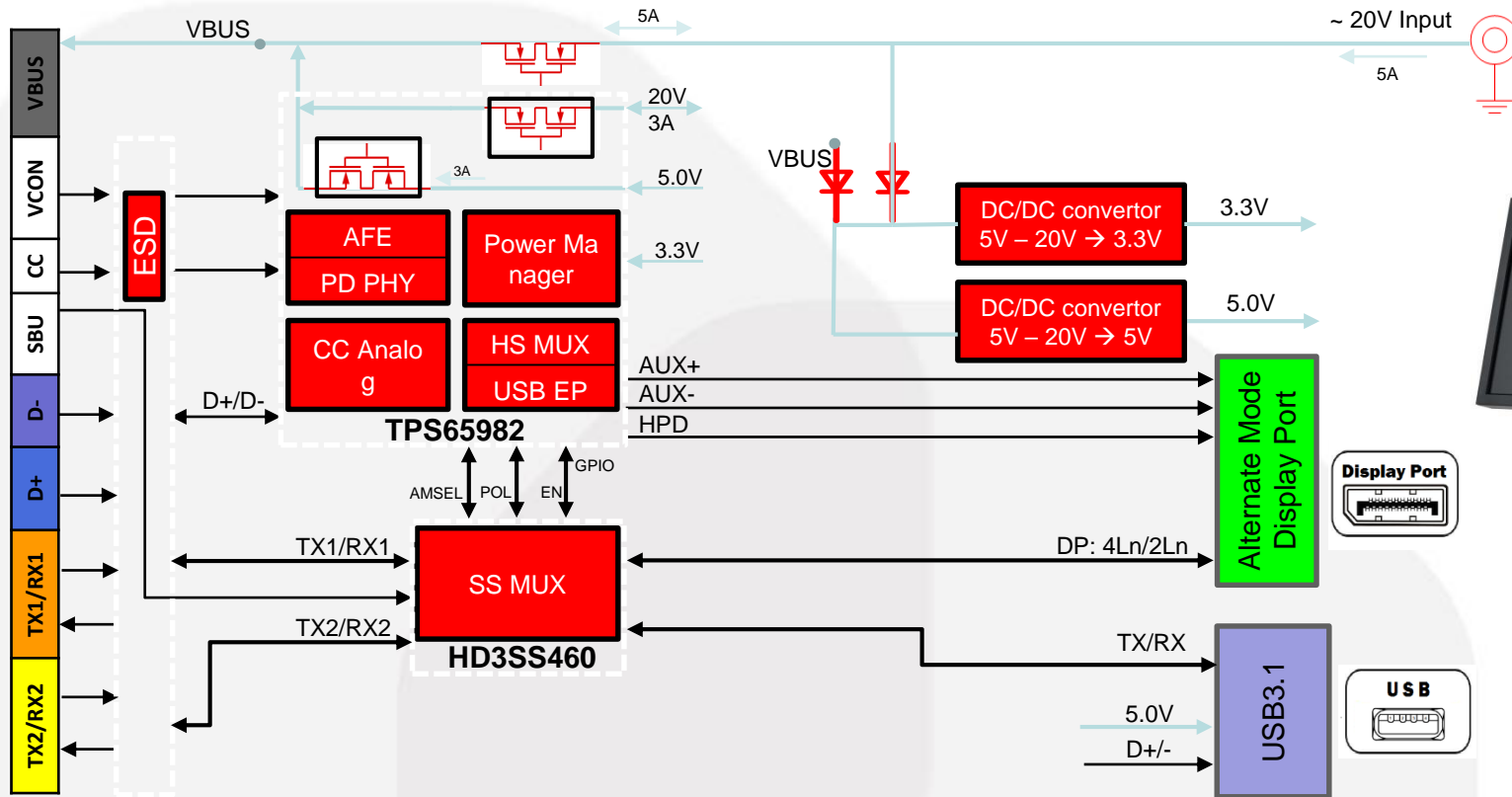

Add Another USB-C/PD Port w TPS 65986

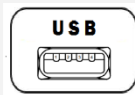
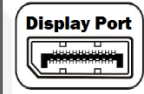

TPS65986 USB Type C Monitor – DP, USB3.1 & Charger

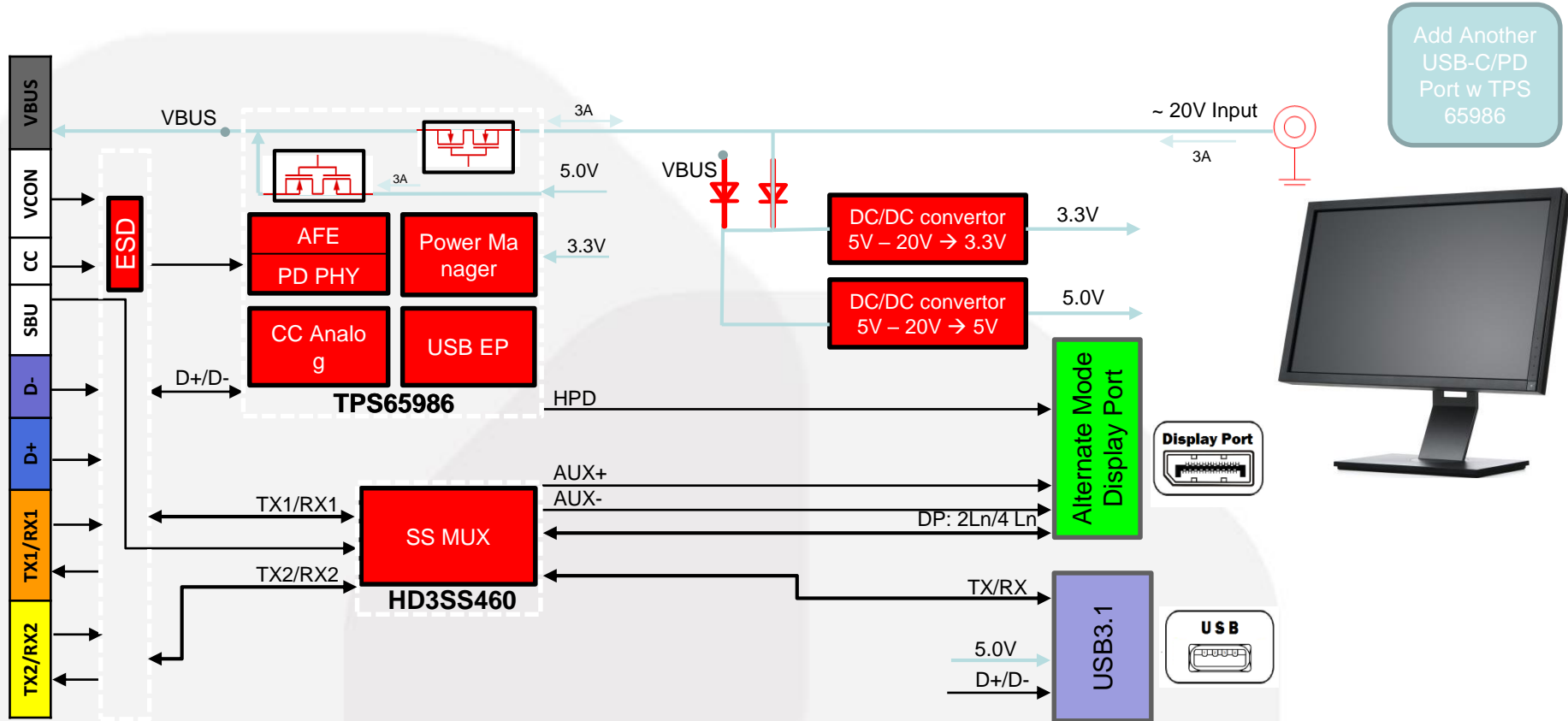

Add Another USB-C/PD Port w TPS 65986

On all designs instead of a Barrel Jack Just add..

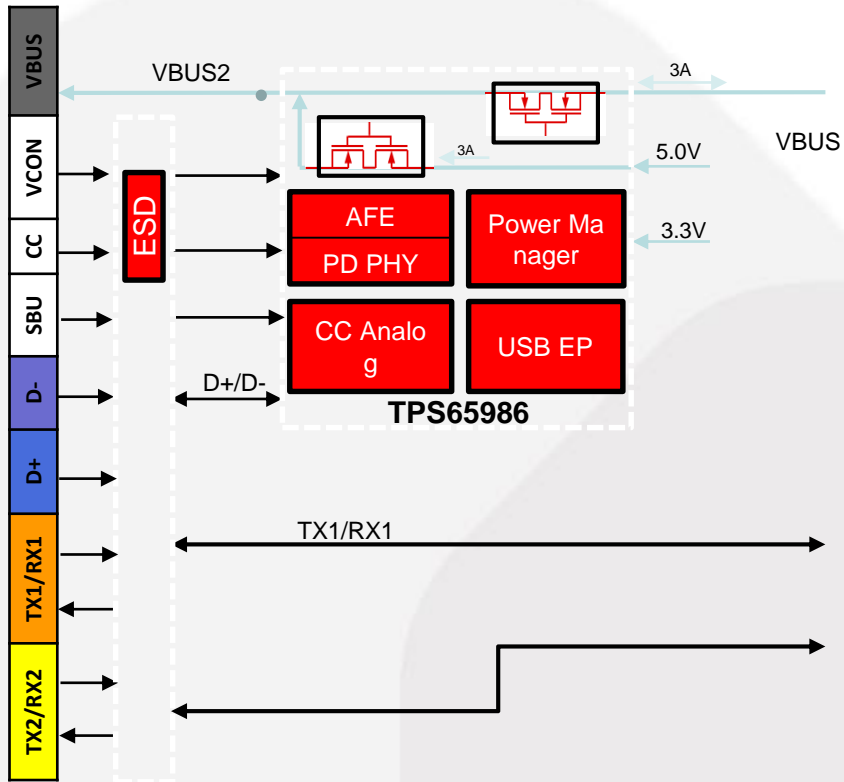

TPS6598x USB Type C Dongle

USB 3.0 + HDMI 2.0 + Type-C (Charging & USB 3.0)

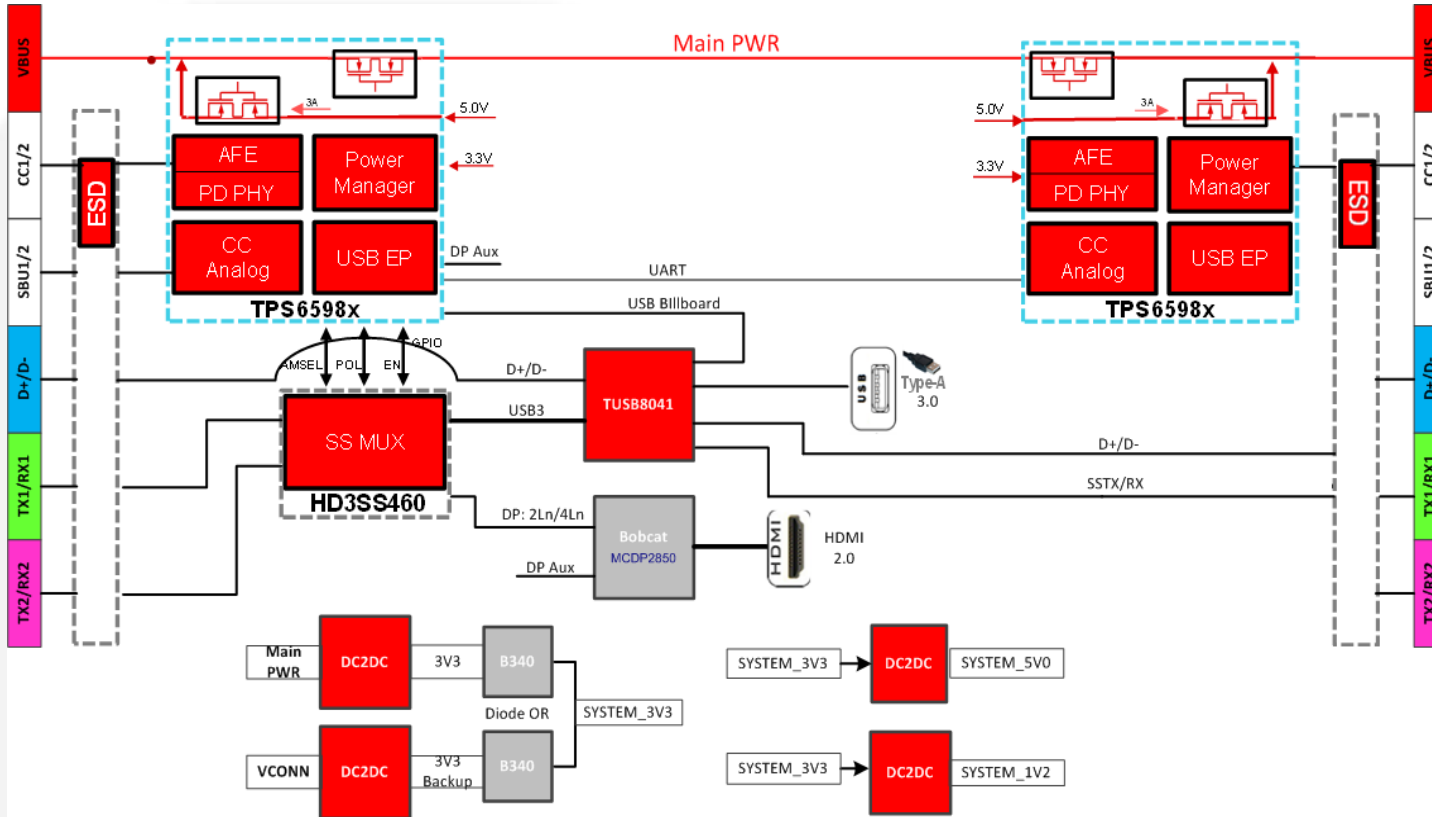

Mini-Dock 2 Port USB-C/PD Reference Design

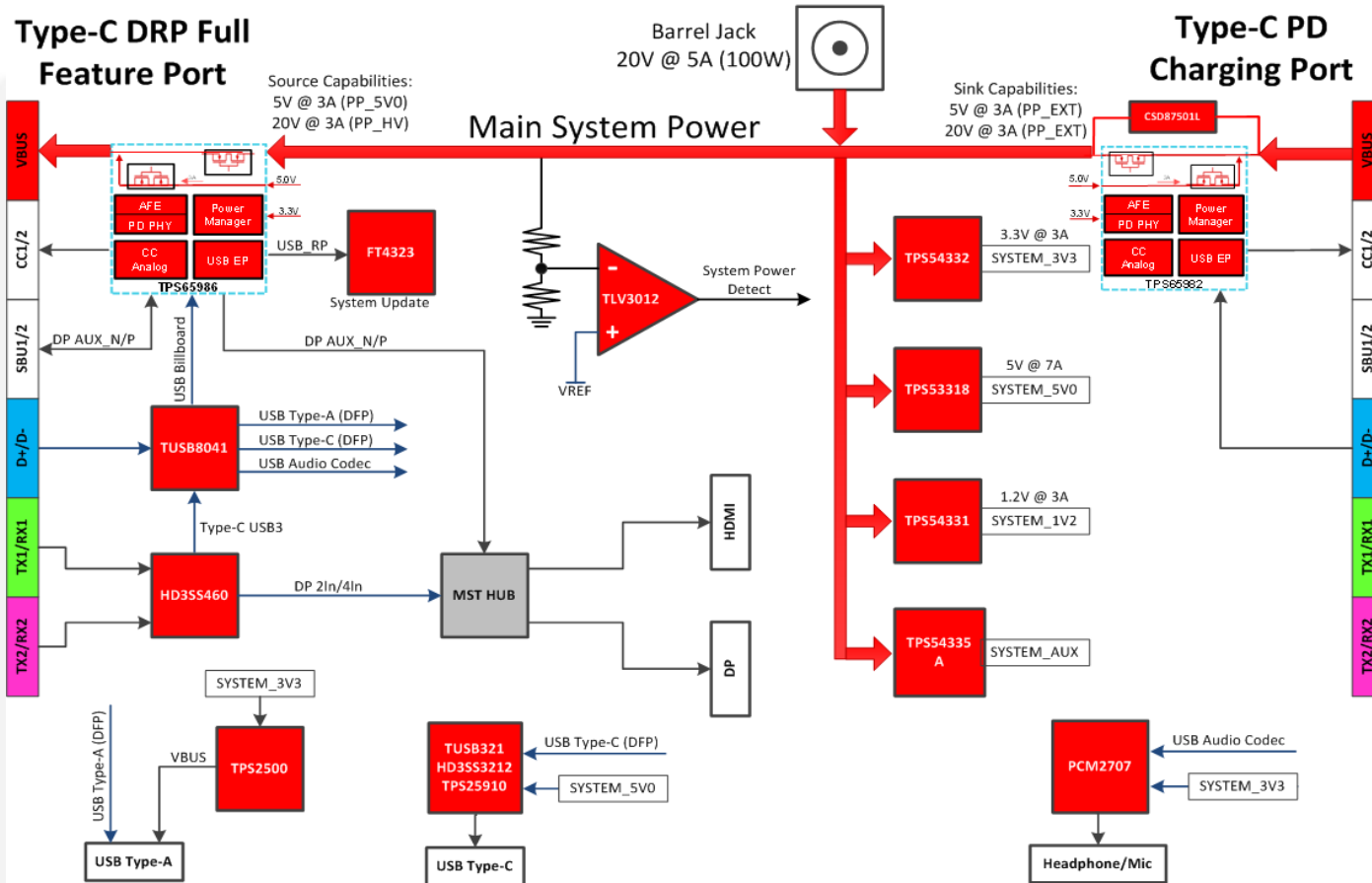

TPS25740 USB Type C PD DFP

- Power Bank/Notebook Adapter (60W)

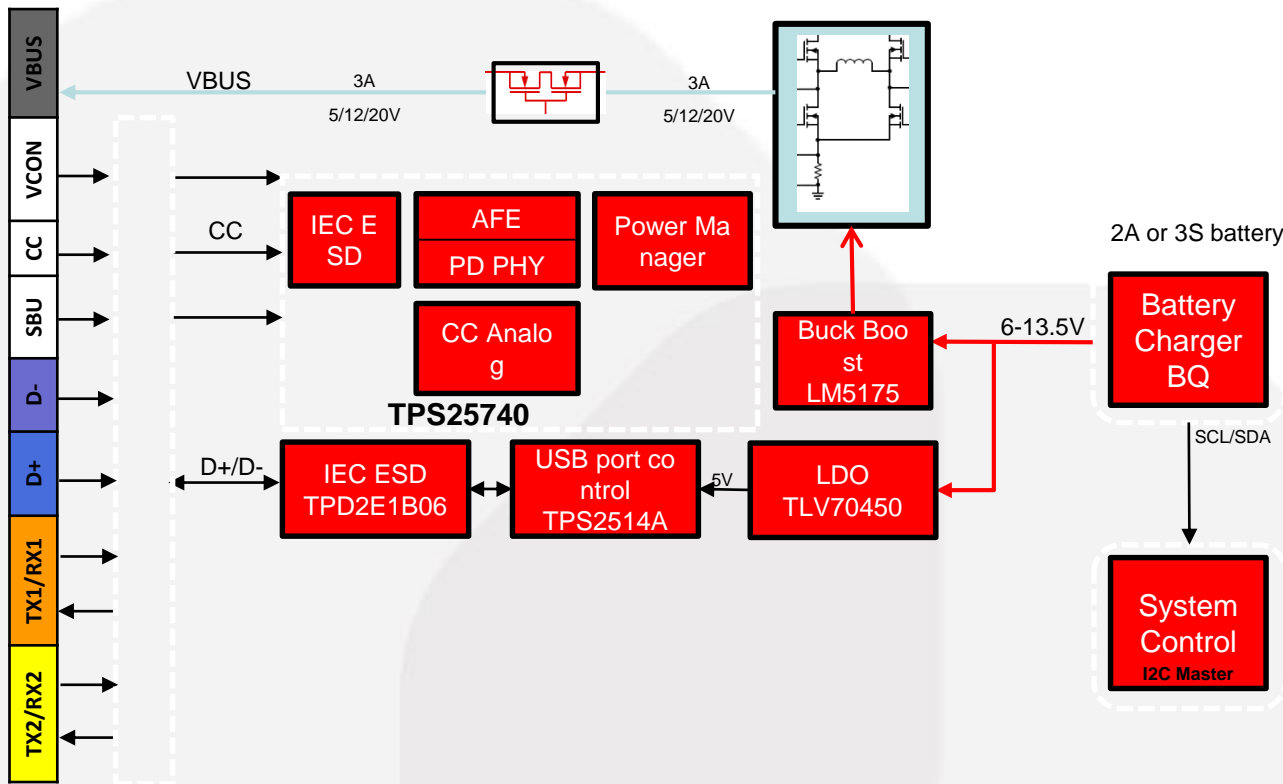

TPS25740/A USB Type C PD DFP

- Car Charger

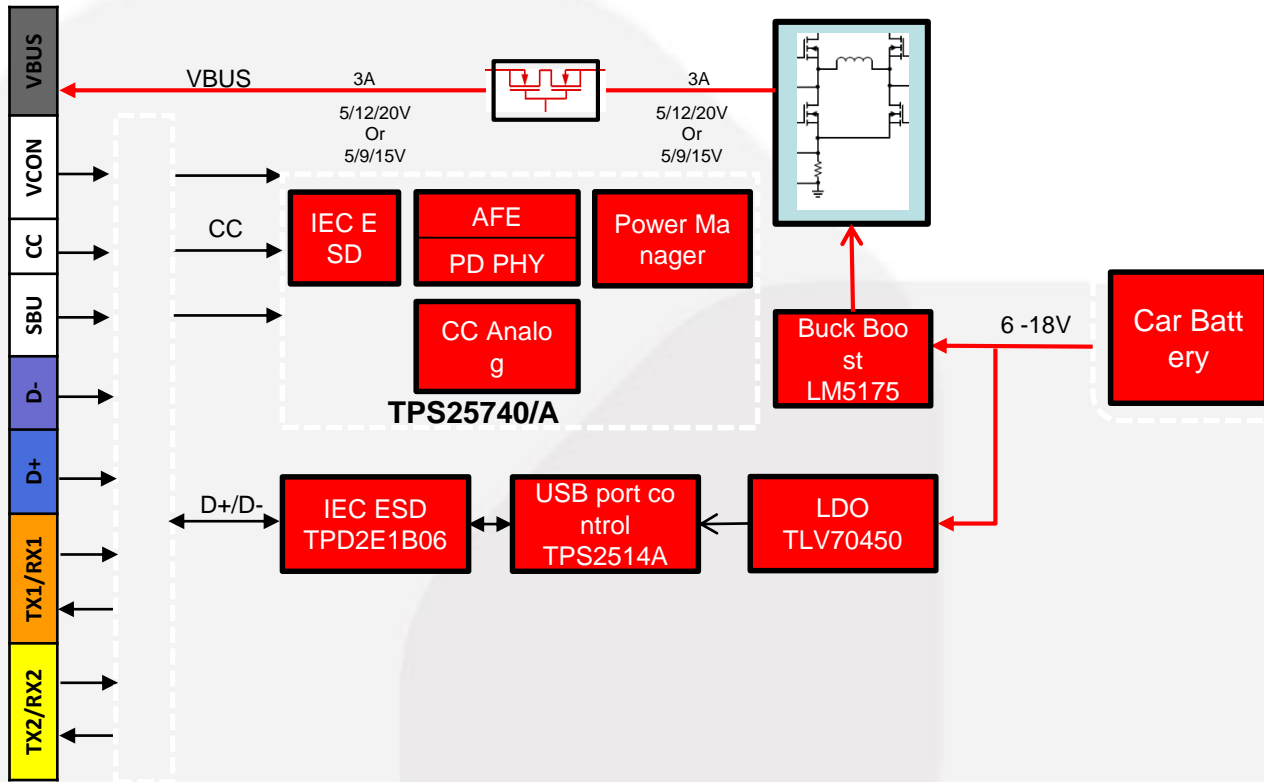

TPS25810 USB Type C DFP

- Power Bank/Notebook Adapter (15W)

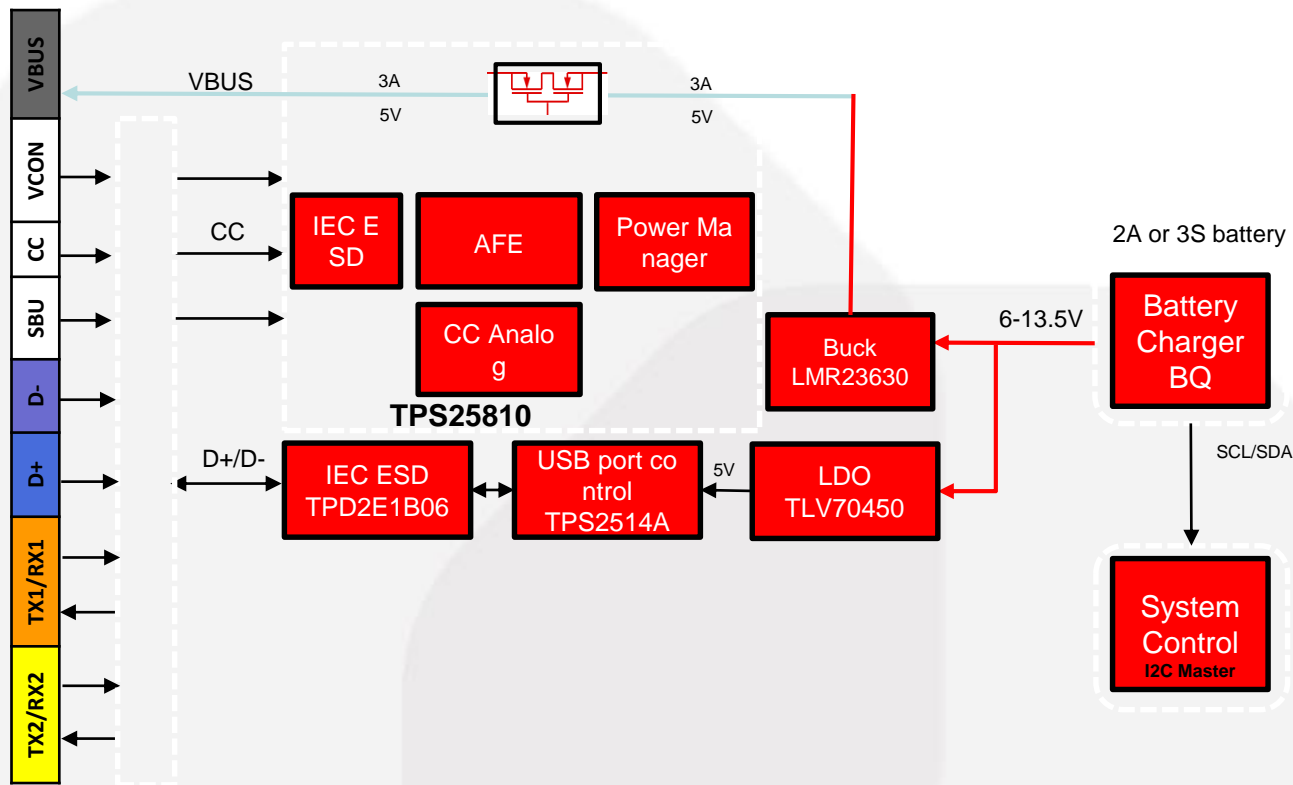

TPS25810 USB Type C DFP

- Car Charger (15W)

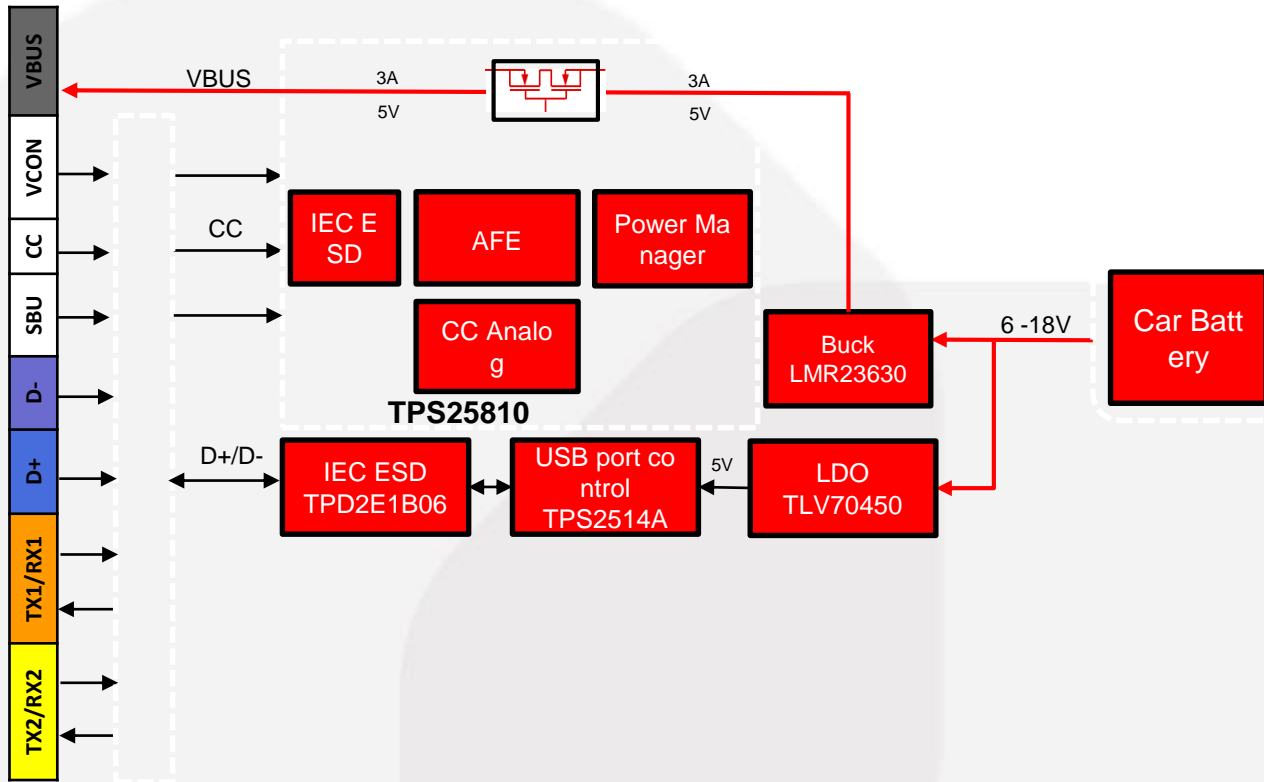

TPS25810 USB Type C DFP

- Monitor/Docking

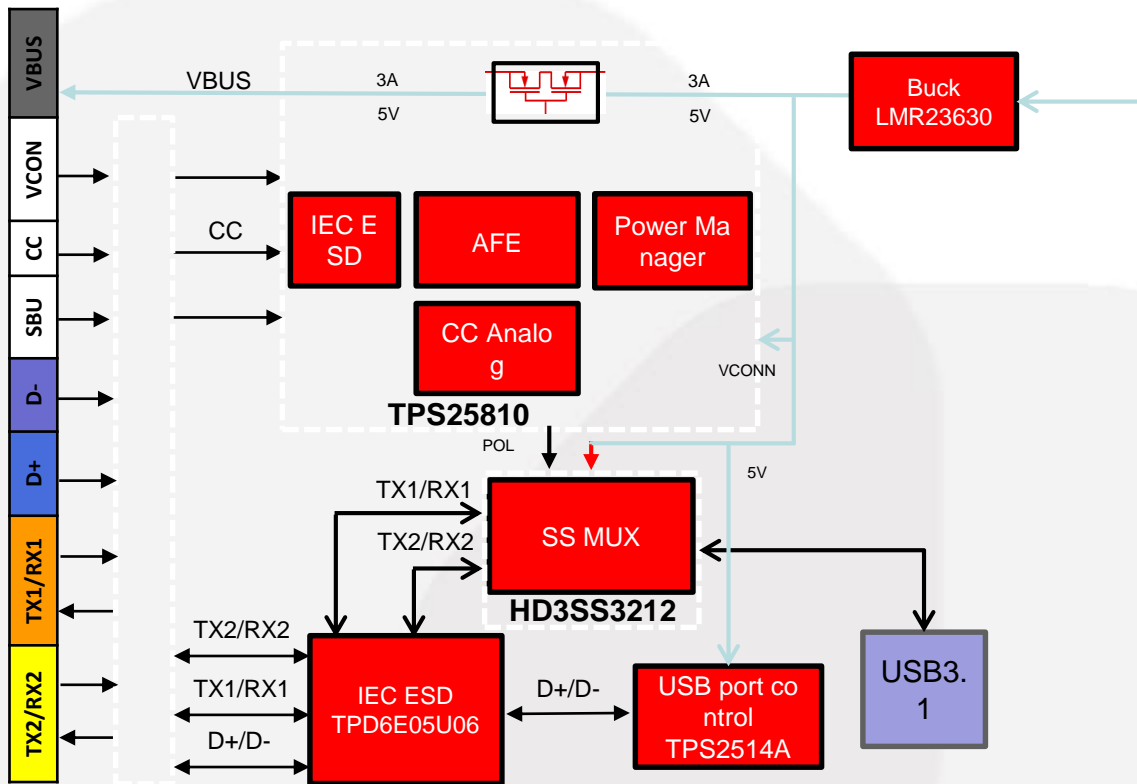



SERIAL
新擘集團

Thank You

Your Integral Component to Success