



AHEAD OF WHAT'S POSSIBLE™

Counting Electrons: Making Ultra-high Sensitivity Femtoamp Measurements

VICKY WONG

Applications Engineer

Precision Measurement and Conditioning

04/27/2017

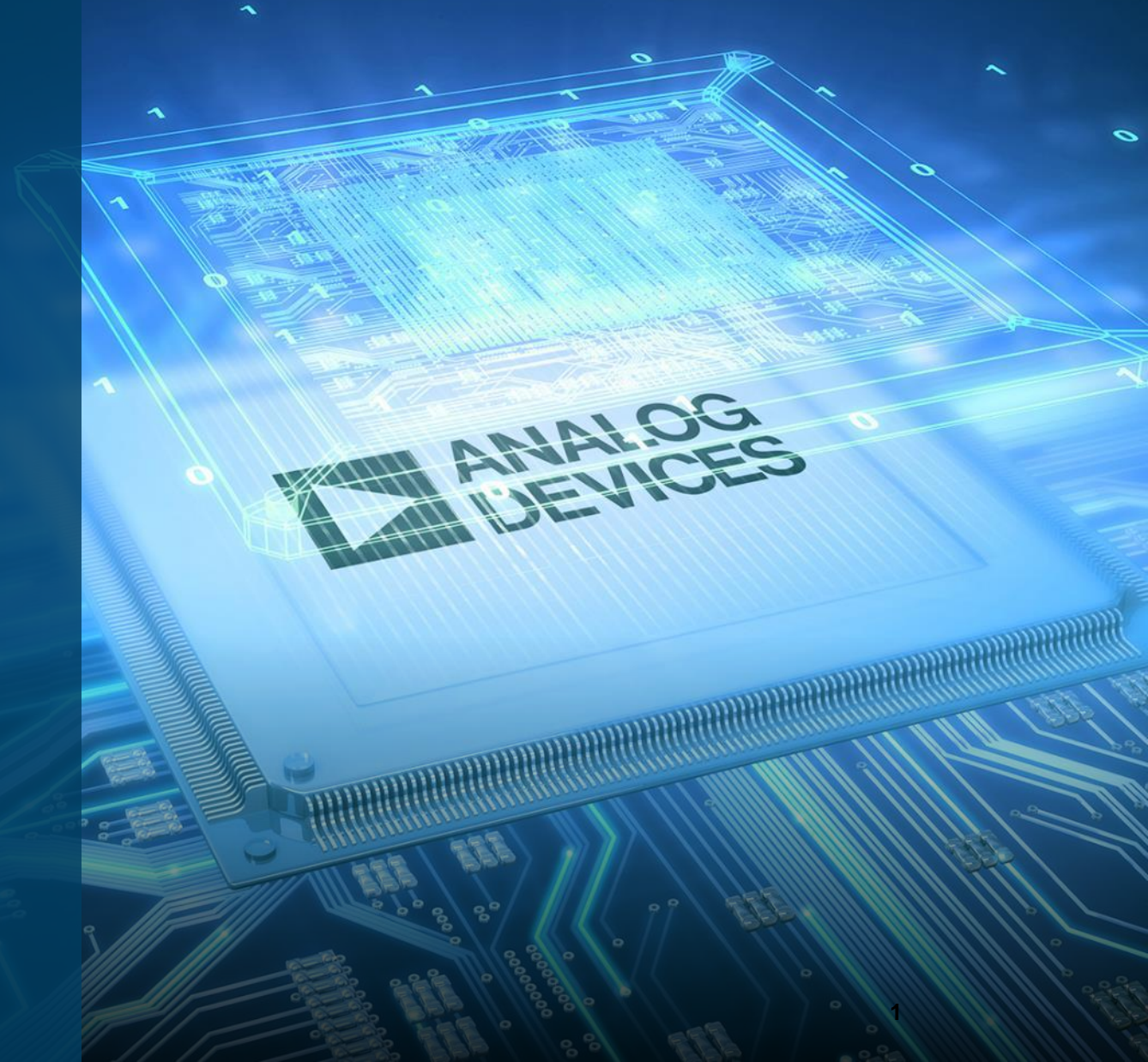

Agenda

- ▶ Solving Customers' Problems:
 - What is the problem out there?
 - How do we solve it?
- ▶ Design Techniques
 - How to select components?
 - What are the noise sources?
- ▶ Measurement Challenges
 - Tips and Considerations
- ▶ Ultra High Sensitivity Femtoampere Measurement Platform
- ▶ Photoelectric Demo



AHEAD OF WHAT'S POSSIBLE™

Solving Customers' Problems

WHAT IS THE PROBLEM OUT THERE AND HOW DO WE SOLVE IT?

Keeping up with Evolving Needs



VOLUME 1 — NUMBER 2 Published by Analog Devices, Inc., Cambridge, Massachusetts JUNE, 1967

Gas Chromatograph Uses Varactor Bridge Flame Detector Amplifier for Enhanced Performance

By Harry Gill, Perkin-Elmer Corp.

Current amplifier circuit based on parametric (varactor bridge) op amp increases gas chromatograph's useful sensitivity, stability, and dynamic range. New design furnishes 5×10^{-15} amp full scale output for recorder and integrator drive.

Electronic engineers have no monopoly on sophisticated instruments for measuring the different components of an unknown input. Gas chromatographs, which have evolved as rapidly since 1950 as microwave spectrum analyzers, enable research chemists to separate tenths of microliters of any vaporizable sample into its individual constituents, and to measure the quantity of each sample-constituent with better than 2% accuracy.

Not all gas chromatographs find their way into research laboratories or advanced chemical plants,

as motorists convicted of dangerous driving can frequently testify. Many police departments use these instruments for qualitative measurements of airborne alcohol. In other novel applications, the gas chromatograph can distinguish vintage wine from last year's crop; detect from a sample of "minced earthworms" that pesticides wash into the soil and stay there (vide Rachel Carson's SILENT SPRING); sniff the noxious fumes in an automobile's exhaust; or bolster an Englishman's conviction that teabags prevent Americans from ever tasting a civilized cup o' tea.



Chianti, vintage 1957, is introduced into the gas chromatograph. Comparison of differences in trace components on the chromatograms may be related to differences in relative quality of individual vintages.

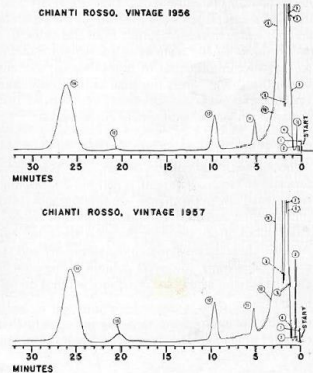

ELECTROMETER- GRADE AMPLIFIER IMPROVES ACCURACY AND REDUCES SIZE



- ▶ Industry's lowest input bias current
- ▶ Very low bias current drift with temperature
- ▶ Unique integrated guard buffer

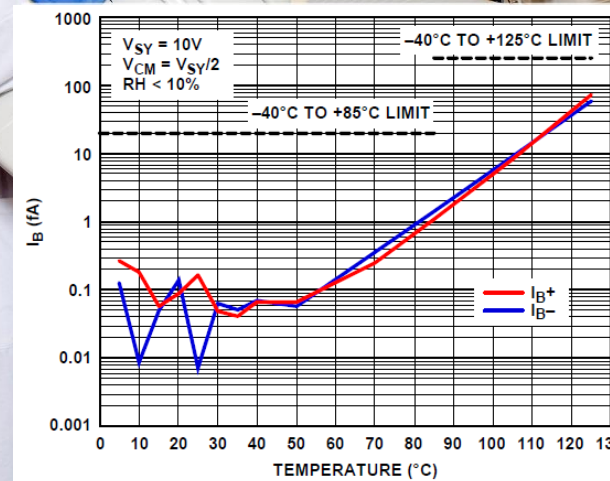

Measurement Instruments Require Increasing Sensitivity

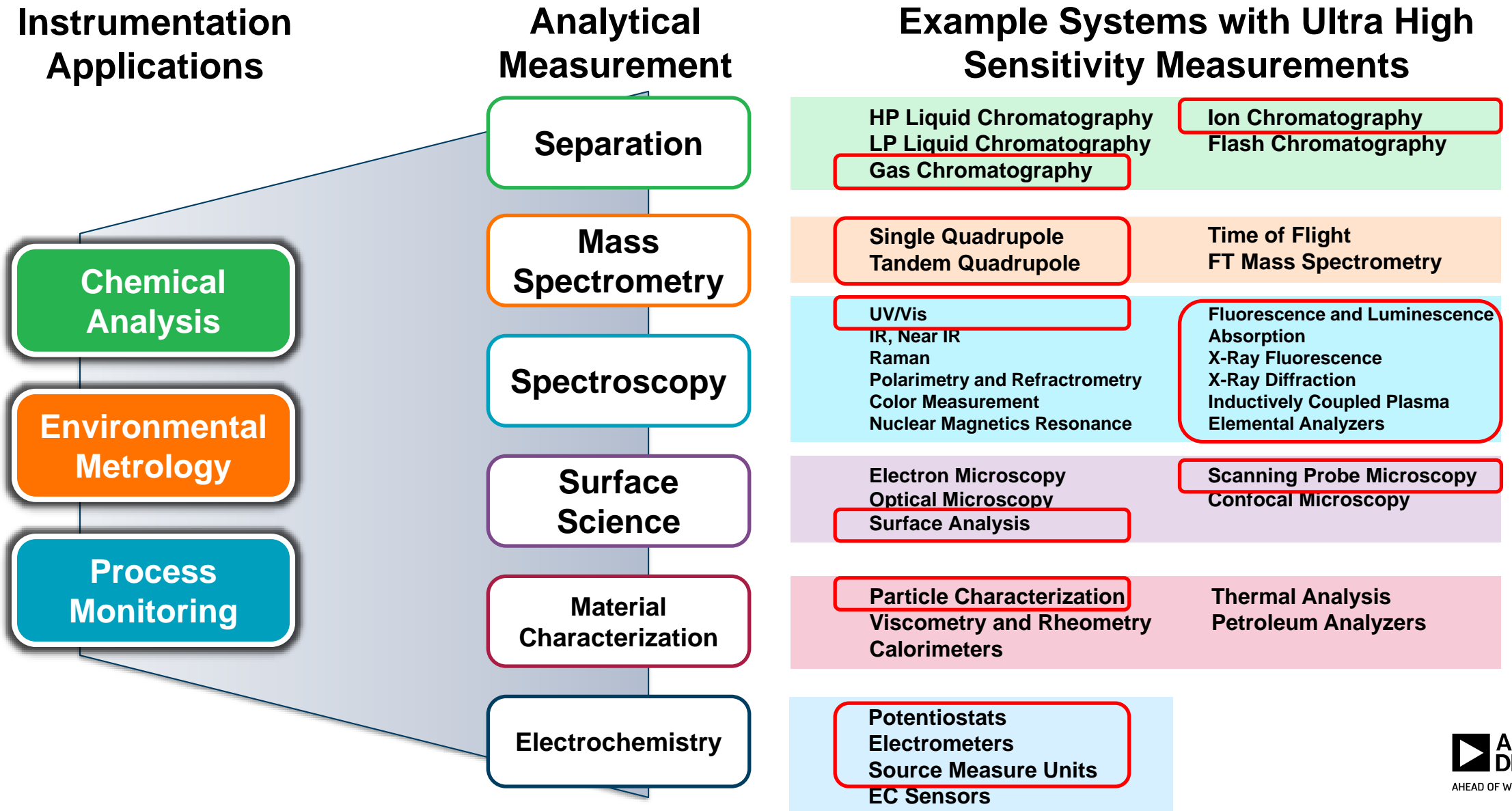

Limits of Detection

- ▶ The measure a signal, the measurement level must be above the noise
- ▶ Low-level measurements require us to go close to the shaded area
- ▶ Special considerations are required to achieve precise and accurate results
- ▶ Electrometers are used for low current measurements

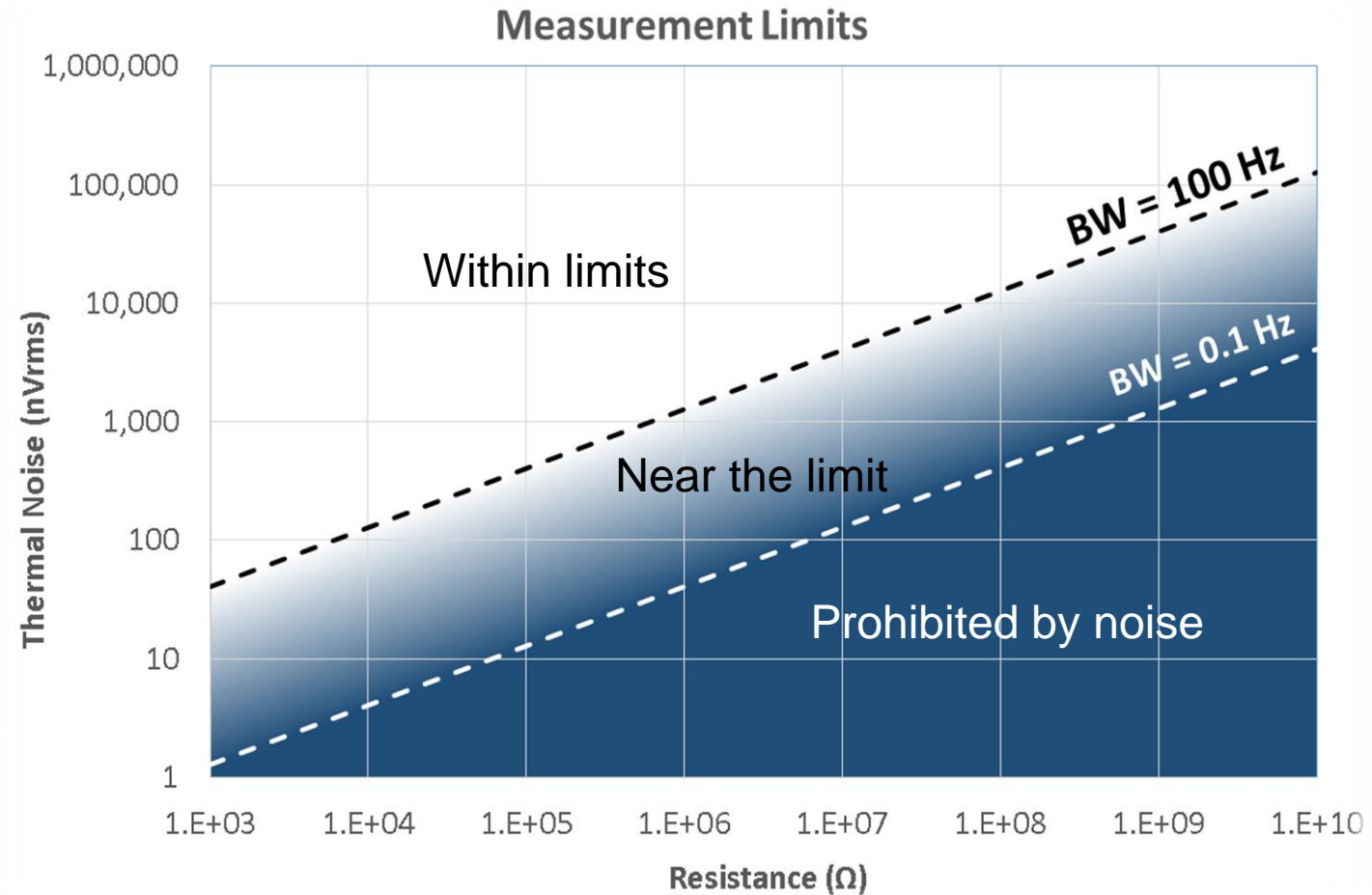

The Electrometer

- ▶ Definition: an electrical instrument for measuring electric charge or electrical potential difference with low leakage current
- ▶ Voltmeter, Ammeter, Ohmmeter, Coulombmeter function
 - Very high input impedance (typically above 100TΩ or as high as 10PΩ)
 - Very low input offset current (less than 50fA or as low as 50aA)
 - Employs transimpedance amplifier for current measurements

Prefix	Symbol	Meaning	Scientific Notation
exa-	E	1,000,000,000,000,000,000	10 ¹⁸
peta-	P	1,000,000,000,000,000	10 ¹⁵
tera-	T	1,000,000,000,000	10 ¹²
giga-	G	1,000,000,000	10 ⁹
mega-	M	1,000,000	10 ⁶
kilo-	k	1,000	10 ³
hecto-	h	100	10 ²
deka-	da	10	10 ¹
—	—	1	10 ⁰
deci-	d	0.1	10 ⁻¹
centi-	c	0.01	10 ⁻²
milli-	m	0.001	10 ⁻³
micro-	μ	0.000 001	10 ⁻⁶
nano-	n	0.000 000 001	10 ⁻⁹
pico-	p	0.000 000 000 001	10 ⁻¹²
femto-	f	0.000 000 000 000 001	10 ⁻¹⁵
atto-	a	0.000 000 000 000 000 001	10 ⁻¹⁸

High Sensitivity Detectors Require Precision Signal Chains to Enable Lowest Detection Levels

Photon/Electron Detectors:
Current Output

Electron or Photon Multiplier

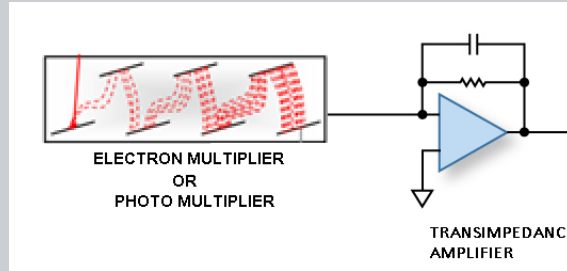

Photodiode

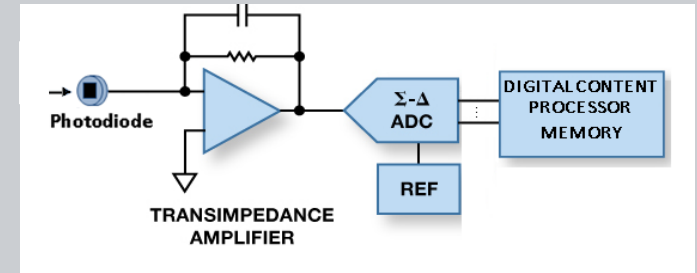

Ion Detectors:
Charge Output

Flame Ionization Detector

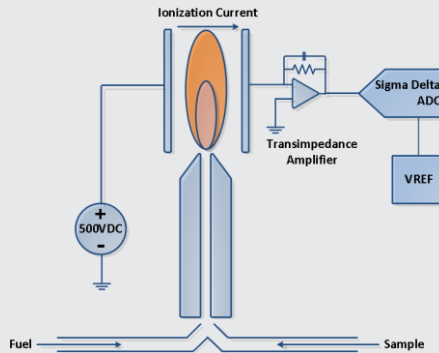

Faraday Cup

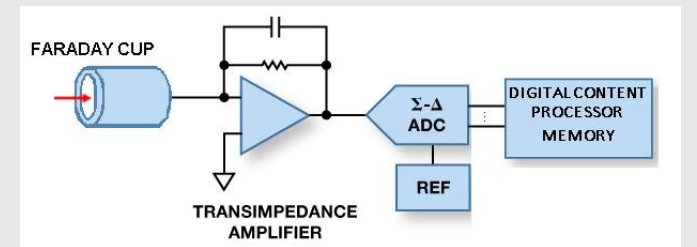

Spectroscopy Example

Spectroscopy: study of interaction of matter and radiated energy
“What is it?” “How much is there?”

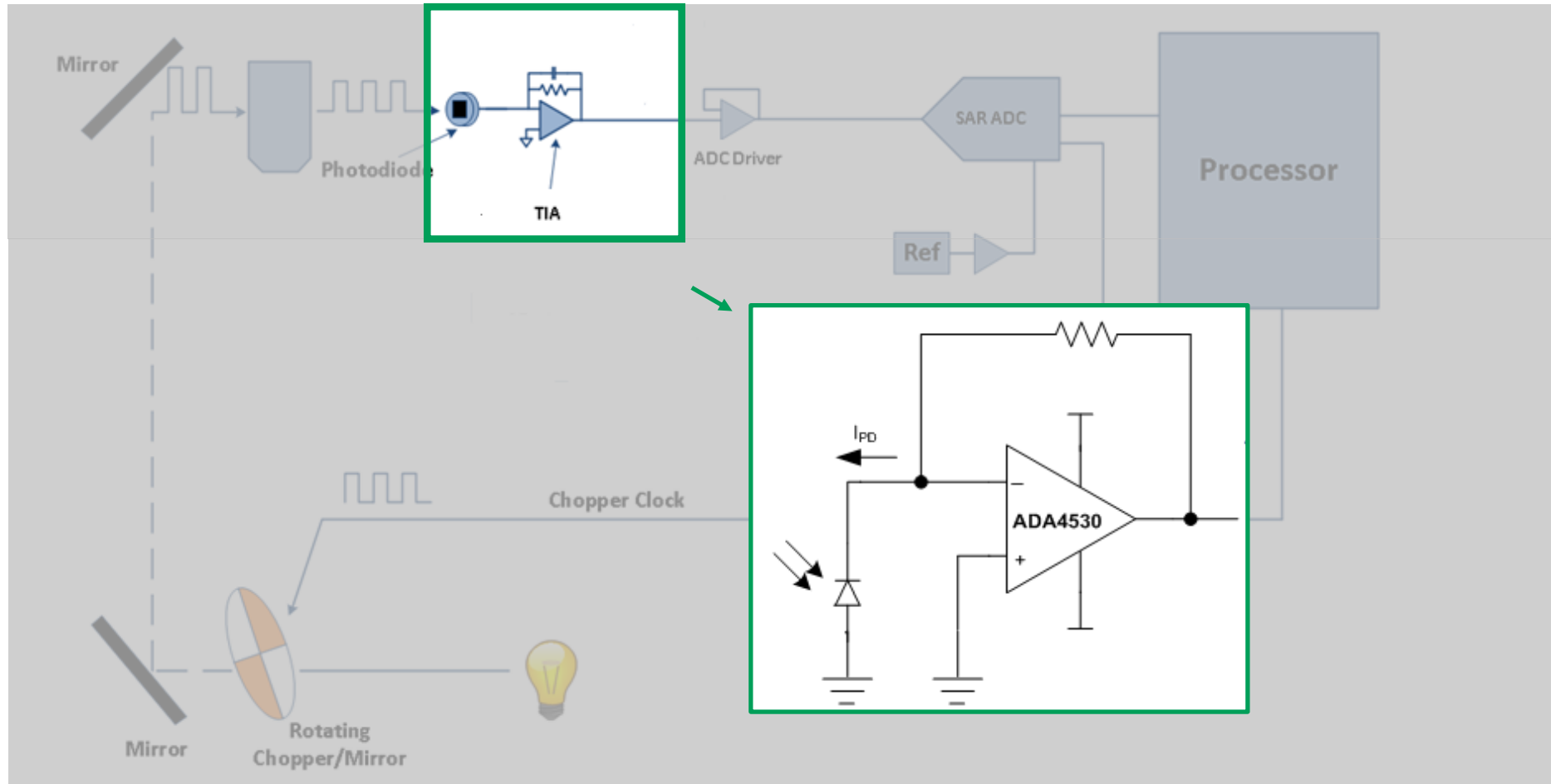

The need for an electrometer-grade amplifier

- ▶ Sensor:
 - Photodiode (light \rightarrow I)
- ▶ Op Amp:
 - Transimpedance Amp (TIA) circuit (I \rightarrow V)
- ▶ Signal:
 - Desired output = 10V
 - Full-scale current = 1nA
 - $R_F = 10G\Omega$
- ▶ Temperature:
 - 15C to 35C

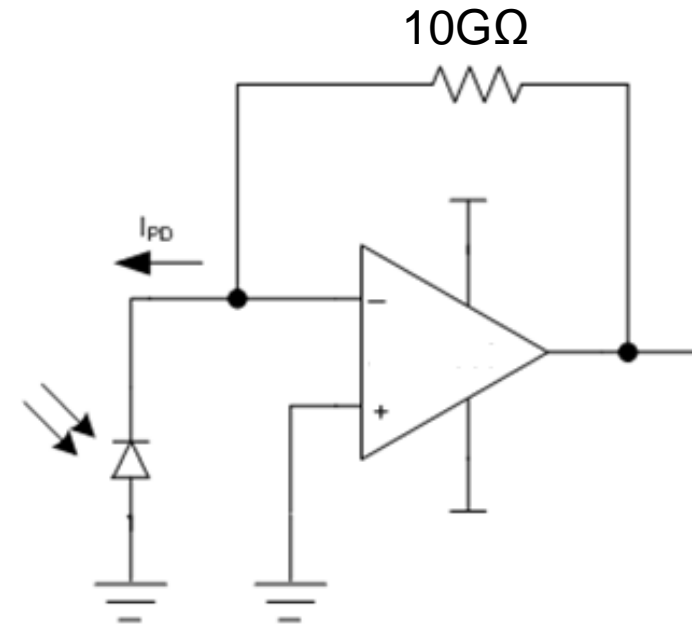

Amp	$I_{BIAS\ MAX}$ @ 25C	$V_{os\ max}$ @ 25C	TCVos	Error for 1nA Full Scale
ADA4622	10 pA	800 μ V	15 μ V/C	1.01 %
AD549	100 fA	500 μ V	15 μ V/C	0.018 %
ADA4530	20 fA	40 μ V	0.5 μ V/C	0.0025 %

ADA4530-1: Not your typical amplifier!

Key Benefits

- ▶ Ultra Low Input Bias Current
Electrometer-Grade Amplifier
- ▶ New level of sensitivity!
 - 0.1fA typ I_B at 25C
 - 20fA max I_B from 25C to 85C
 - 250fA max I_B at 125C
 - Low offset drift of 0.5uV/C max
- ▶ Easy to use
 - Integrated guard buffer
 - Pin out optimized for input pin isolation from power supplies
 - Surface mount package

624 electrons / sec !

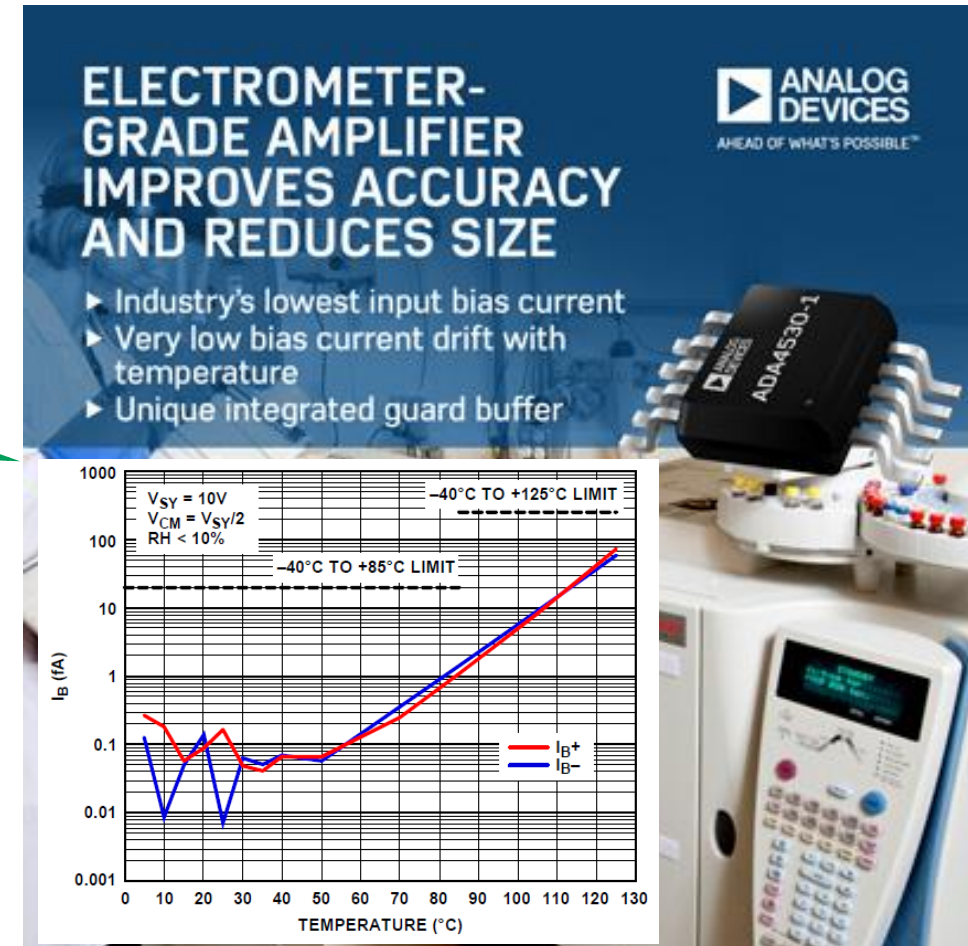
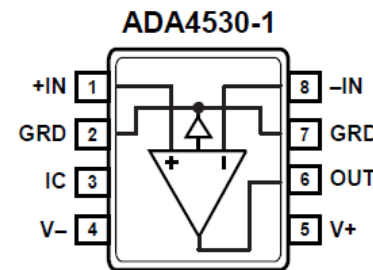

45x lower input bias current and 10x better DC precision than the leading competitor part

Beyond Typical Characterization Targeting Low Level Current Measurement

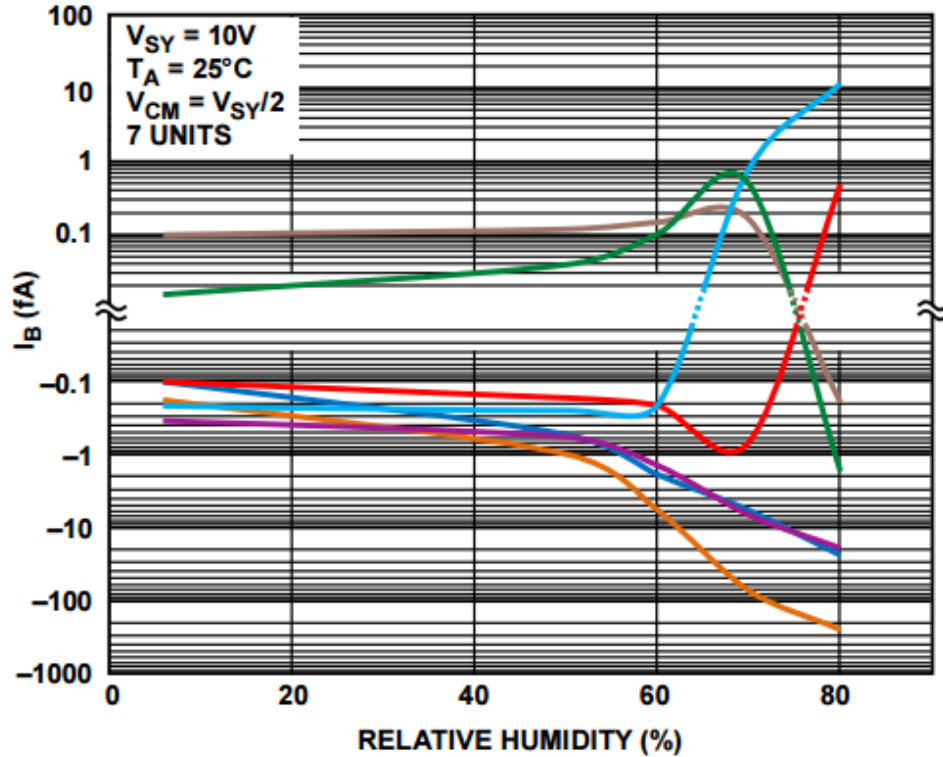

Figure 112. Effective Input Bias Current vs. Relative Humidity

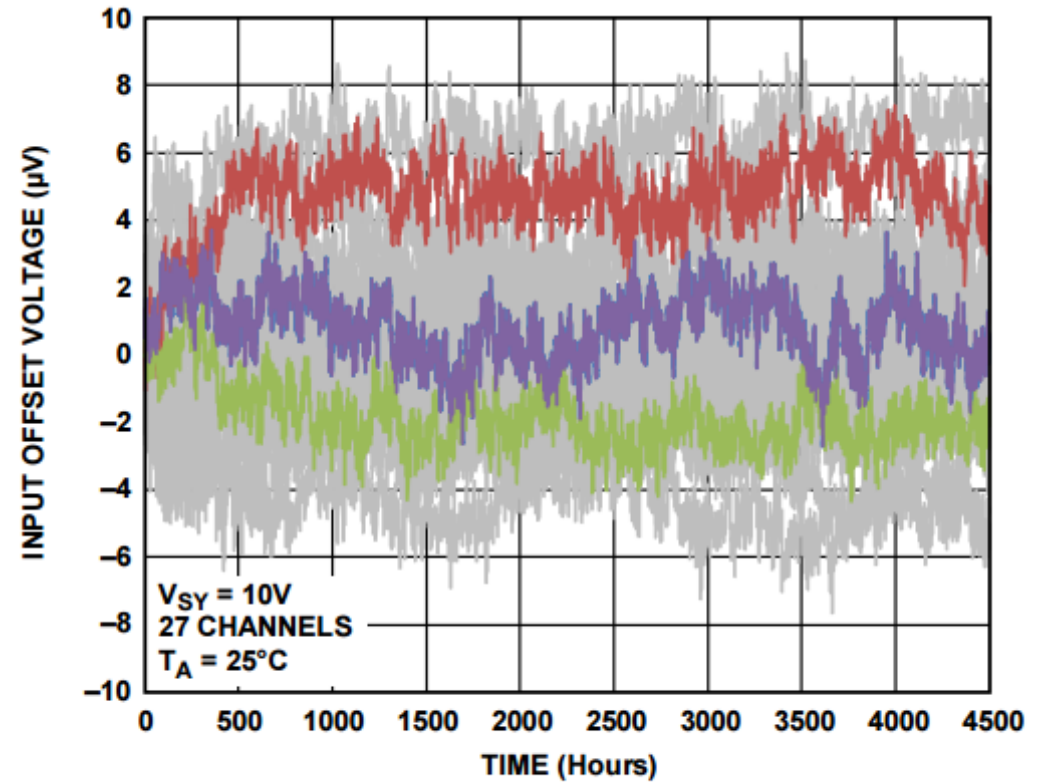

Figure 19. V_{OS} Long-Term Drift



AHEAD OF WHAT'S POSSIBLE™

Design Example

HOW DO I SELECT COMPONENTS AND WHAT ARE THE NOISE SOURCES?

The Implementation Challenges

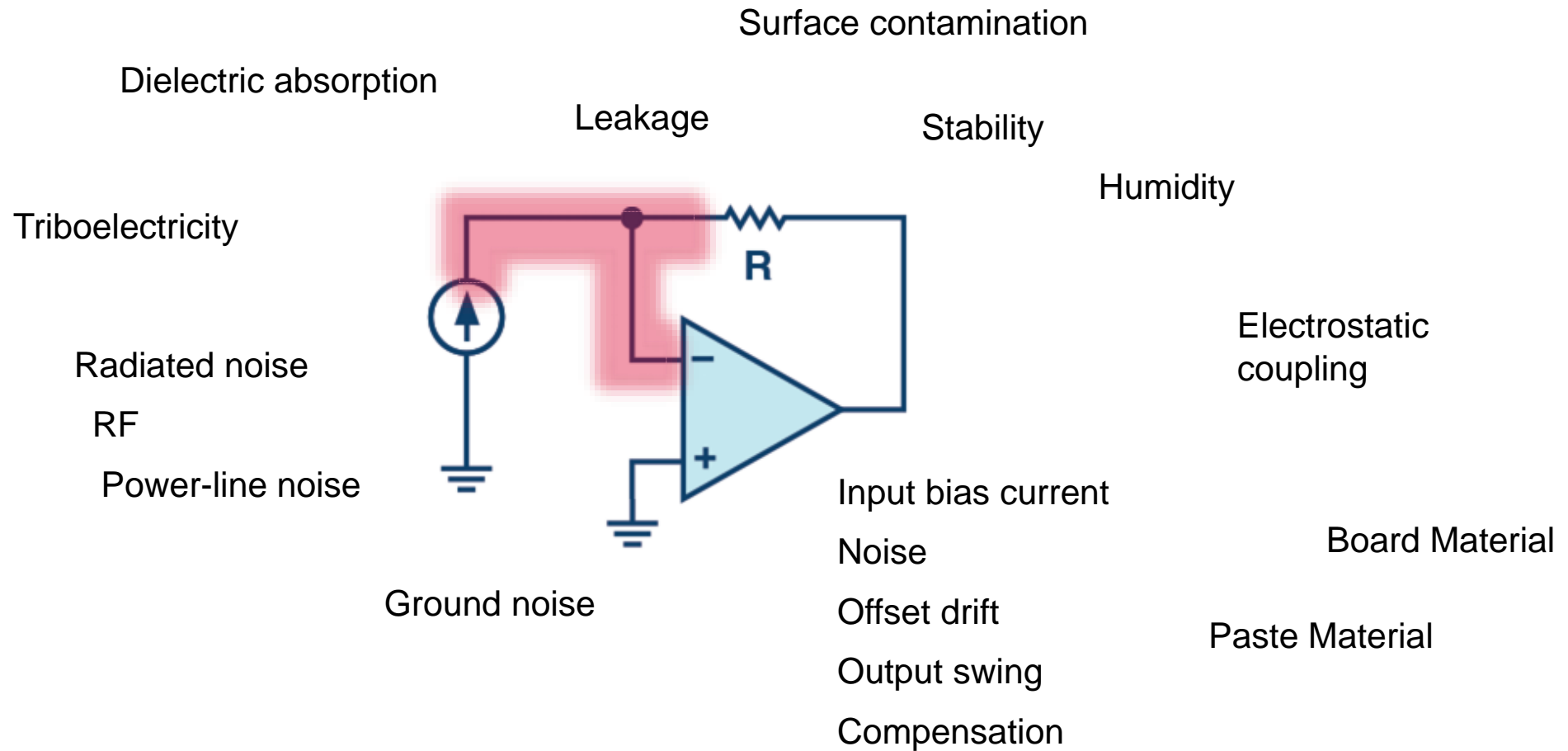

Design Example

Hamamatsu S1226-18BQ

$I_{PD} \text{ max} = 500\text{pA}$

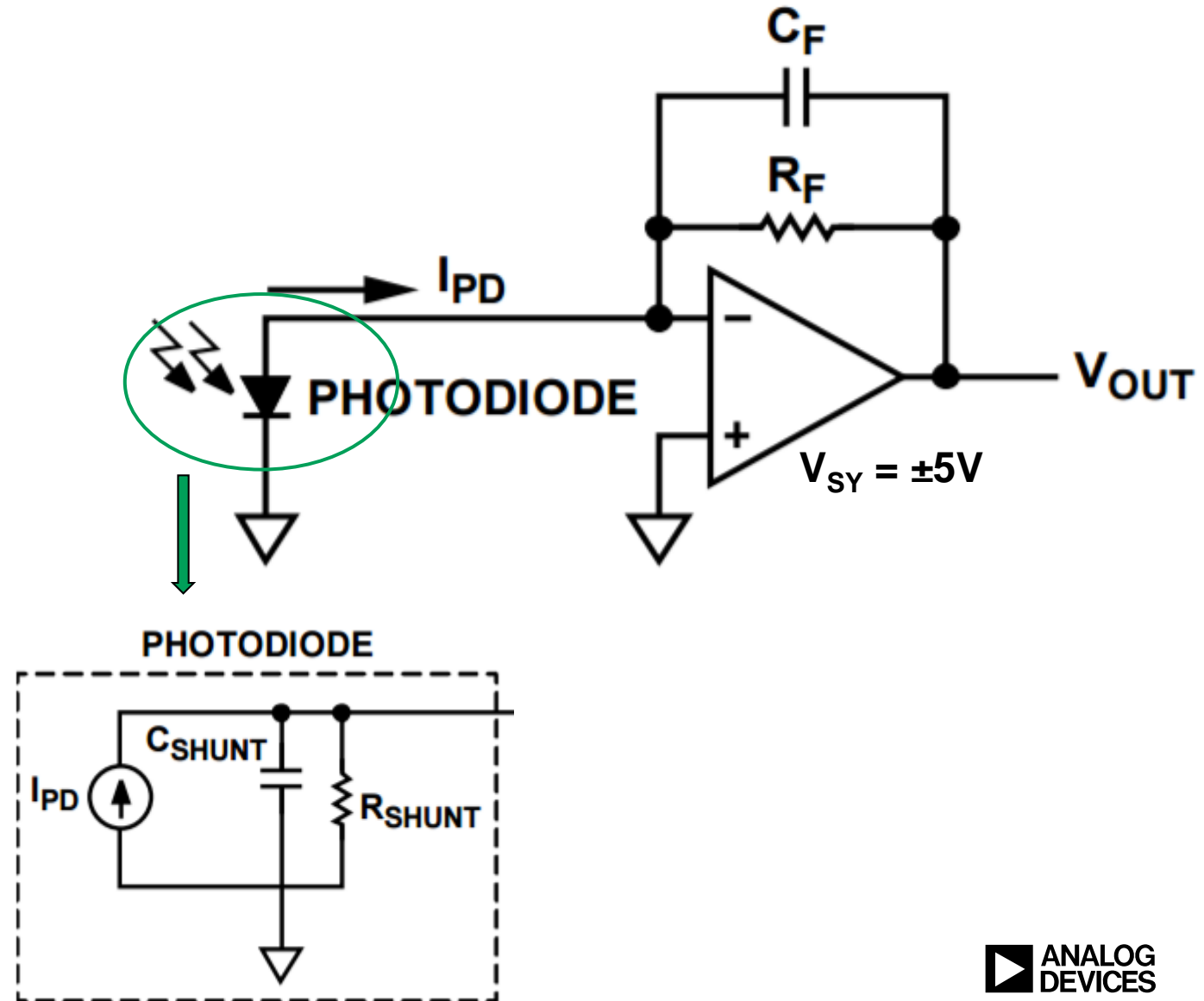

- $R_{SHUNT} = 50 \text{ G}\Omega \text{ typ}, 5\text{G}\Omega \text{ min}$
- $C_{SHUNT} = 35\text{pF}$
- Operating temp: -20C to 60C

R_F selection

$$RF \text{ Thermal Noise, } V_{N,Rf} = \sqrt{4 \times k \times T \times R_F}$$

$$V_{OUT} = I_{PD} \times R_F$$

$$SNR = \frac{V_{OUT}}{V_{N,Rf}}$$

$$SNR \propto \sqrt{R_F}$$

SNR improves by $\sqrt{R_F}$

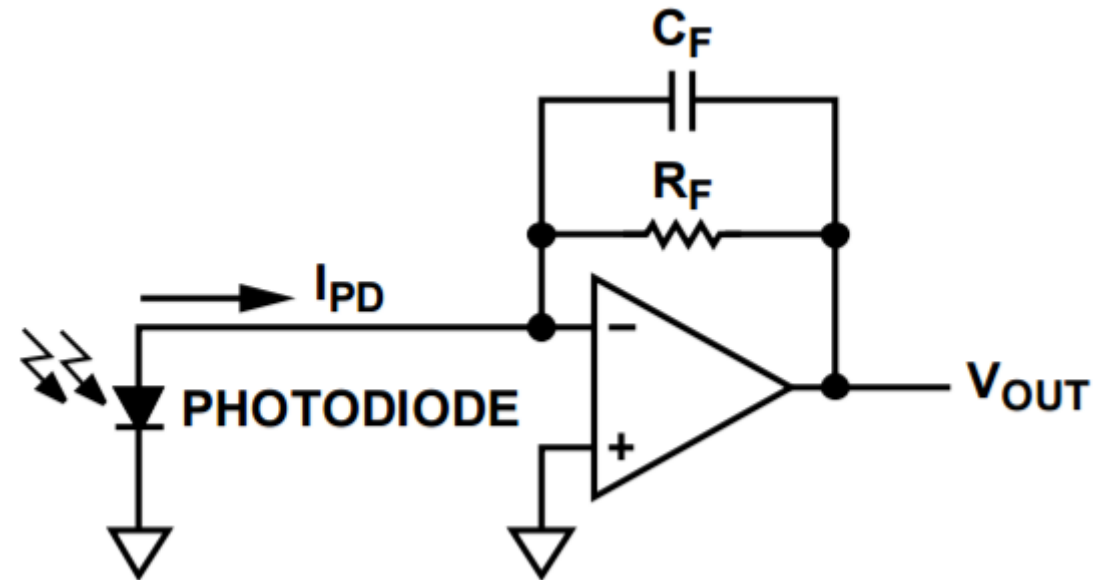

R_F Selection

Factors that Limit Upper Limit of R_{SHUNT}

- ▶ Maximum output swing

$$V_{OUT} = I_{PD} \times R_F$$

- ▶ Signal bandwidth

$$f_{SIGNAL} = \frac{1}{2\pi R_F C_F}$$

- ▶ R_{SHUNT}

- R_{SHUNT} decreases with increasing temperature

$$\text{Noise Gain @ DC} = 1 + \frac{R_F}{R_{SHUNT}}$$

- ▶ Current Noise

- Amp current noise > R_F thermal noise

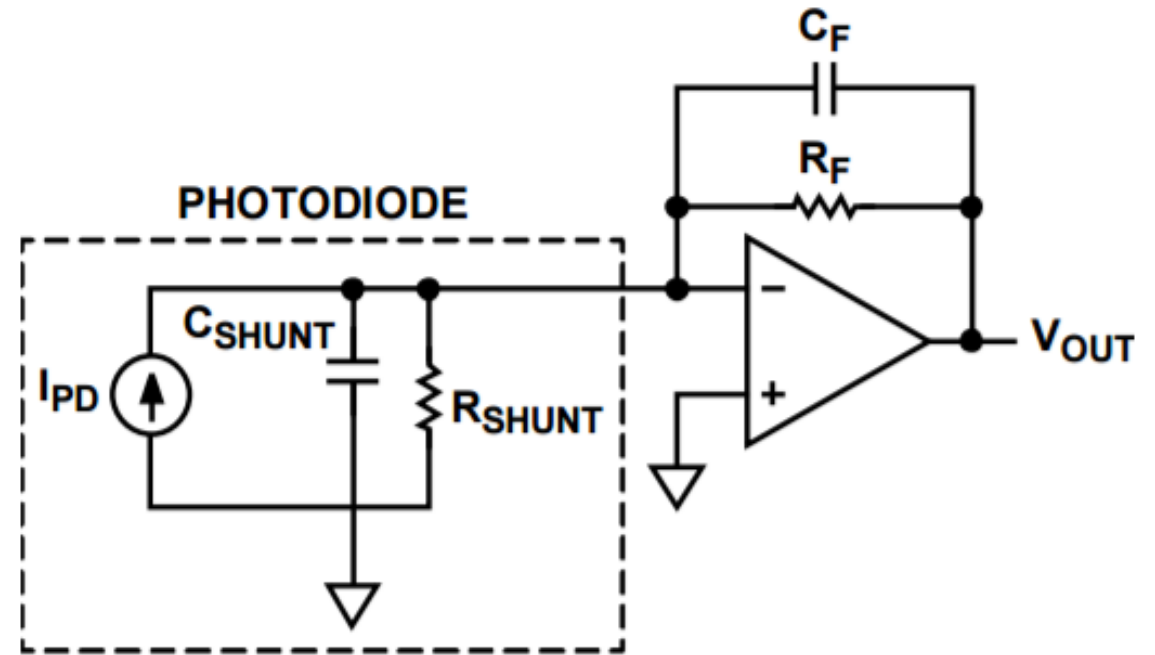

DC Error Budget

Error Source	Equation	ADA4530-1	
		25 C	60C
R_{SHUNT}		5 GΩ	442 MΩ
V_{OS}		40 μV	40 μV + 18 μV
Noise Gain	$1 + \frac{R_F}{R_{SHUNT}}$	3	23
Vos Error RTO	$V_{OS} \times \text{Noise Gain}$	120 μV	1.3 mV
I_B		20 fA	20 fA
I_B Error RTO	$I_B \times R_F$	200 μV	200 μV
Total Error RTO		320 μV	1.5 mV
Total Error RTI		32 fA	150 fA

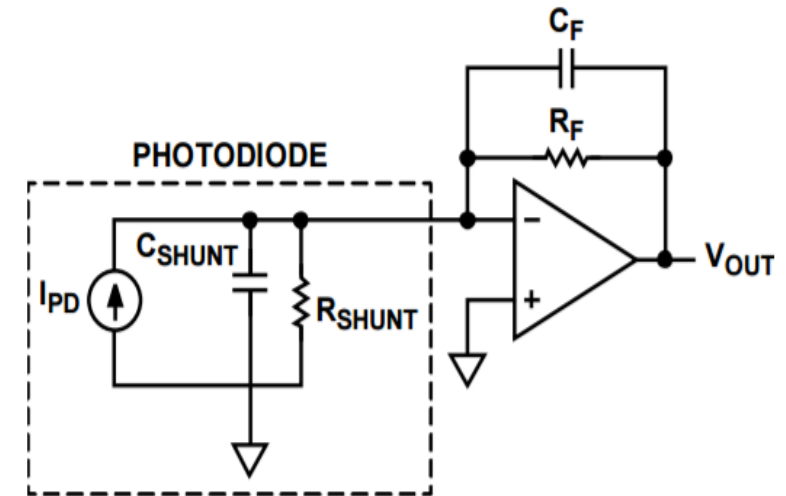

RTO: Referred to Output
RTI: Referred to Input

DC Error Budget

Error Source	Equation	ADA4530-1		Comp A	
		25 C	60C	25 C	60C
R_{SHUNT}		5 G Ω	442 M Ω	5 G Ω	442 M Ω
V_{OS}		40 μ V	40 μ V + 18 μ V	150 μ V	150 μ V + 140 μ V
Noise Gain	$1 + \frac{R_F}{R_{SHUNT}}$	3	23	3	23
Vos Error RTO	$V_{OS} \times Noise\ Gain$	120 μ V	1.3 mV	450 μ V	6.8 mV
I_B		20 fA	20 fA	20 fA	220 fA
I_B Error RTO	$I_B \times R_F$	200 μ V	200 μ V	200 μ V	2.2 mV
Total Error RTO		320 μ V	1.5 mV	320 μ V	9 mV
Total Error RTI		32 fA	150 fA	65 fA	900 fA

RTO: Referred to Output

RTI: Referred to Input

AC Performance

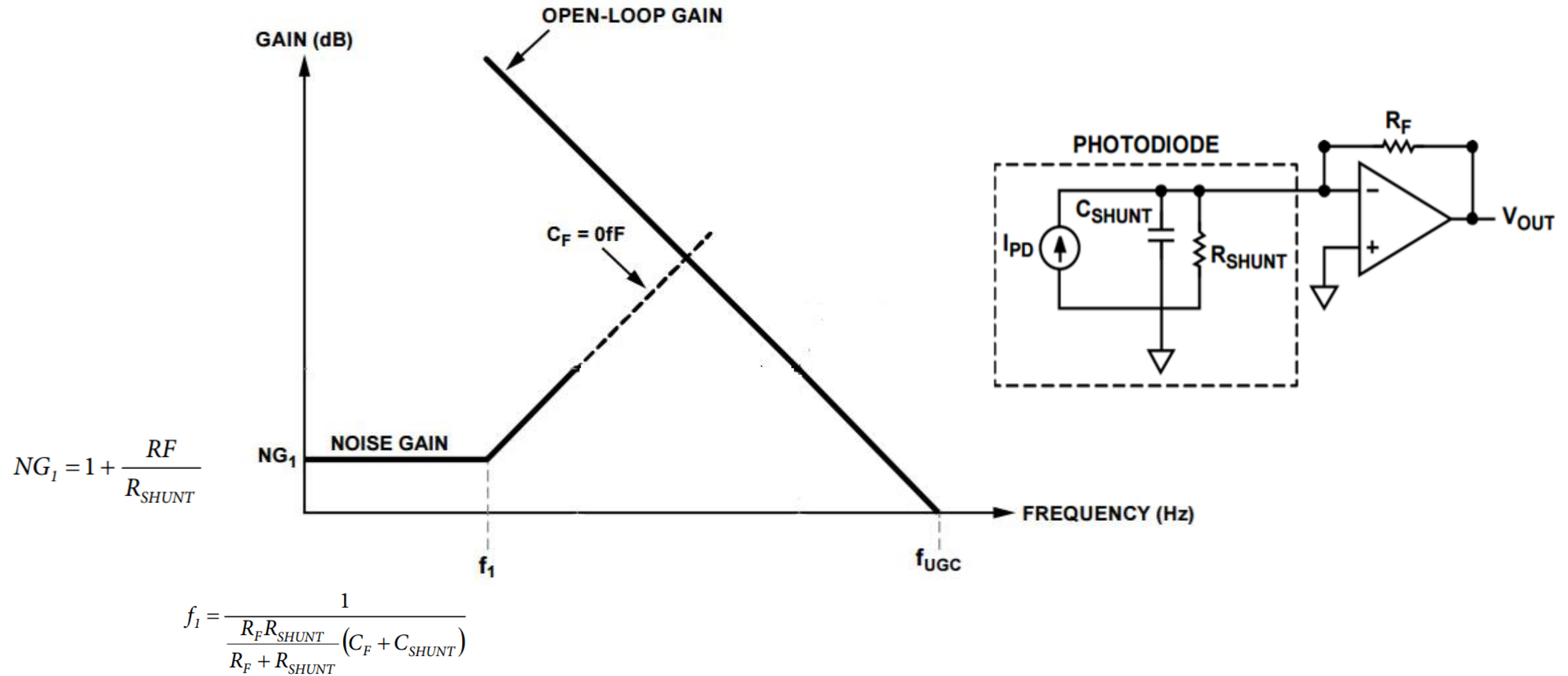

AC Performance

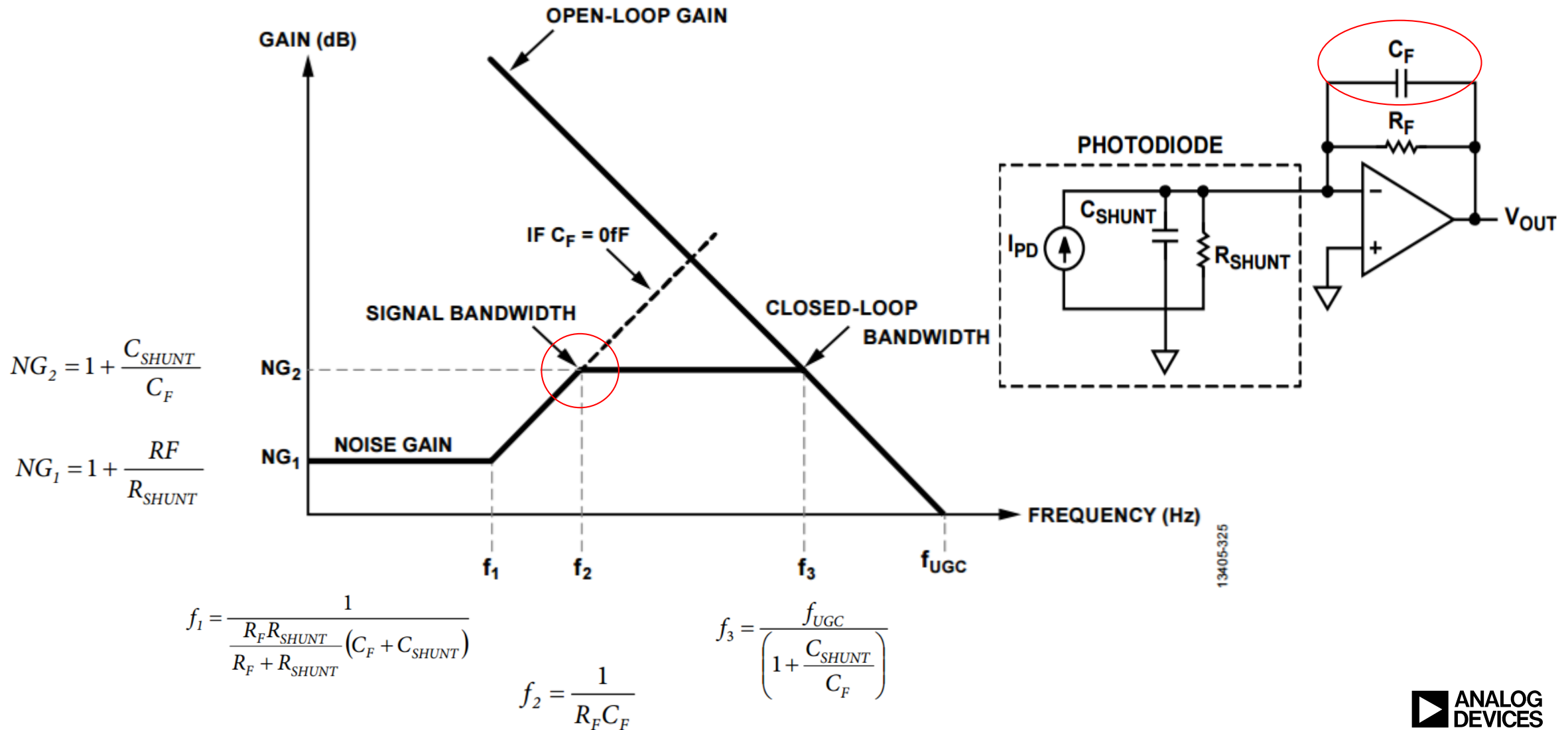

Noise sources

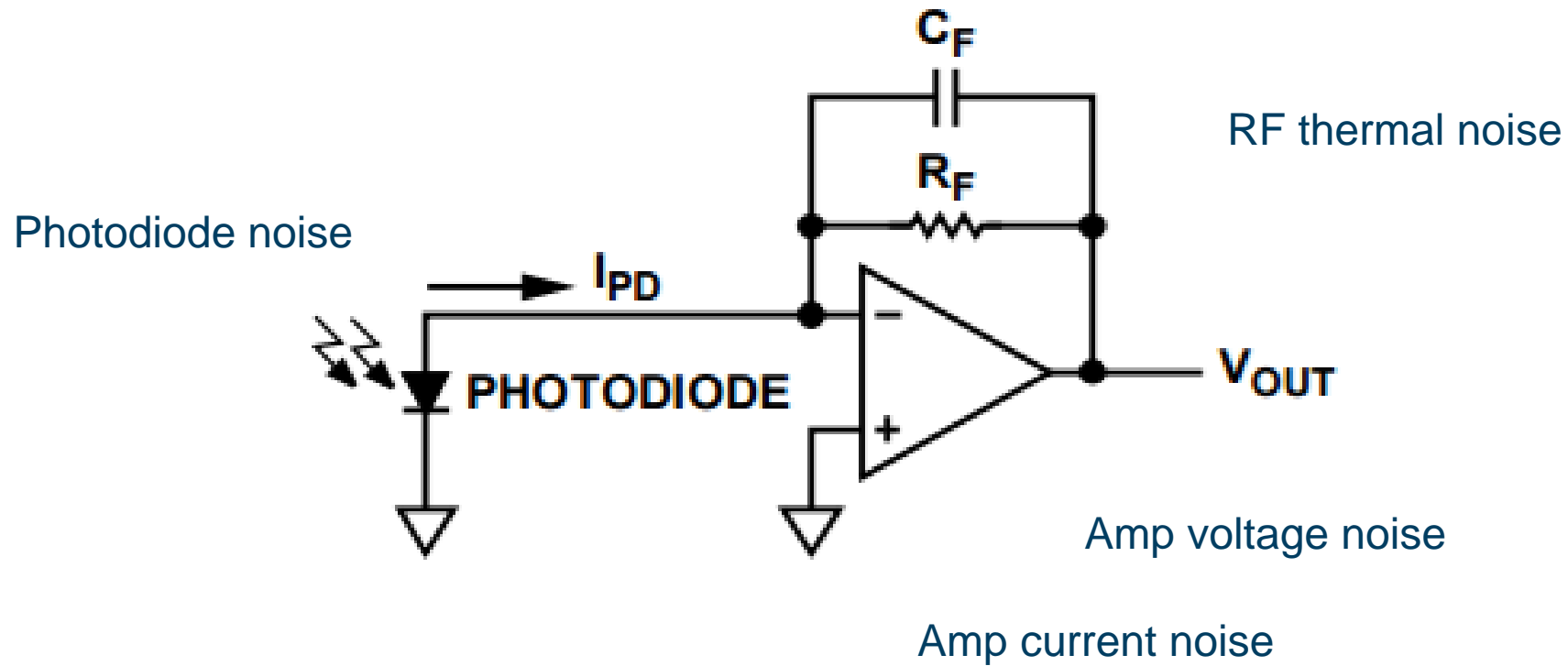

Low Frequency Noise

Noise Source	RTO Noise Equation	Noise BW	RTO Noise @ 25C	RTO Noise @ 60C
R_F	$\sqrt{4 k T R_F}$	$\frac{\pi}{2} f_2$	12.8 uV/rtHz	13.5uV/rtHz
R_{SHUNT} (Photodiode)	$\frac{R_F}{R_{SHUNT}} \sqrt{4 k T R_{SHUNT}}$	$\frac{\pi}{2} f_2$	18 uV/rtHz	64uV/rtHz
Amp Current Noise	$I_N R_F$	$\frac{\pi}{2} f_2$	700 nV/rtHz	2.4 uV/rtHz
Total LF Noise (NSD)			22 uV/rtHz	66 uV/rtHz
Total LF Noise (RMS)			195 uVrms	585 uVrms

Notes:

$$f_2 = \frac{1}{R_F C_F} = 50\text{Hz}$$

* NSD: Noise Spectral Density

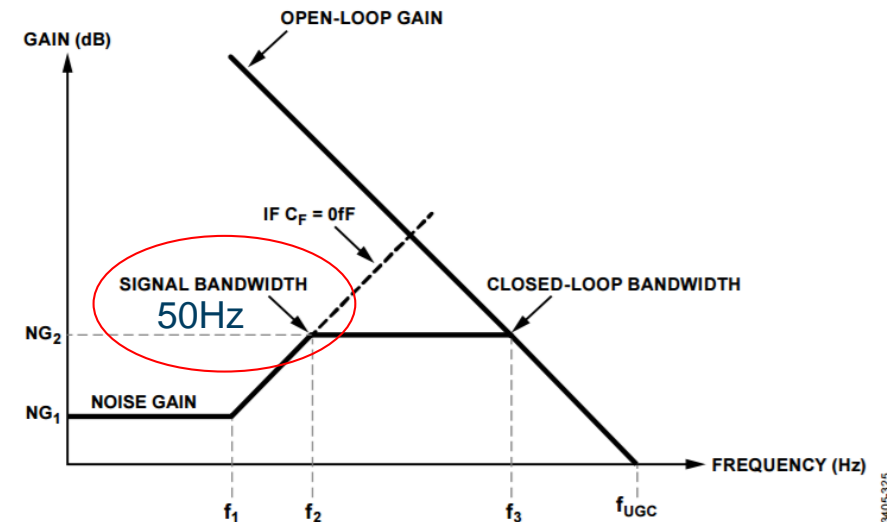
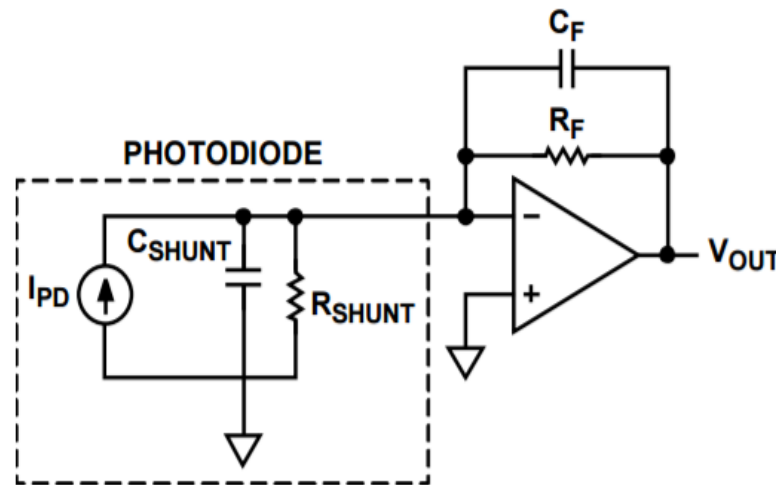

High Frequency Noise

Noise Source	RTO Noise Equation	Noise BW	RTO Noise @ 25C	RTO Noise @ 60C
Amp Voltage Noise	$V_N \times \left(1 + \frac{C_{SHUNT}}{C_F}\right)$	$\frac{\pi}{2} f_3$	1.6 uV/rtHz	1.7 uV/rtHz
Total HF Noise			271 uVrms	286 uVrms

Notes:

$$f_3 = \frac{f_{UGC}}{\left(1 + \frac{C_{SHUNT}}{C_F}\right)} = 17 \text{ kHz}$$

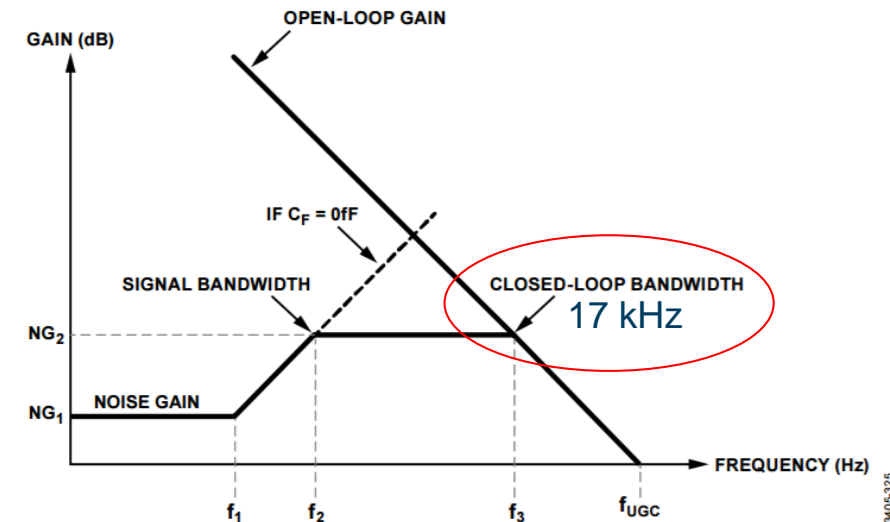
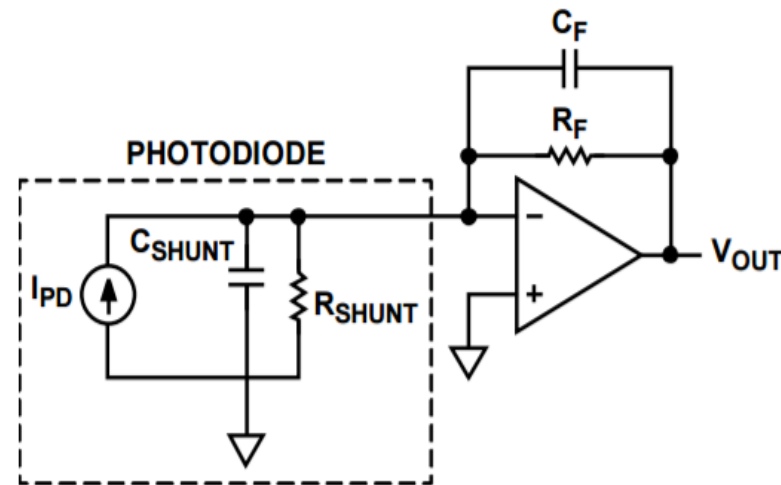

Noise Summary

Noise Source	RTO Noise Equation	Noise BW	RTO Noise @ 25C	RTO Noise @ 60C
R_F	$\sqrt{4 k T R_F}$	$\frac{\pi}{2} f_2$	12.8 uV/rtHz	13.5uV/rtHz
R_{SHUNT} (Photodiode)	$\frac{R_F}{R_{SHUNT}} \sqrt{4 k T R_{SHUNT}}$	$\frac{\pi}{2} f_2$	18 uV/rtHz	64uV/rtHz
Amp Current Noise	$I_N R_F$	$\frac{\pi}{2} f_2$	700 nV/rtHz	2.4 uV/rtHz
Amp Voltage Noise	$V_N \times \left(1 + \frac{C_{SHUNT}}{C_F}\right)$	$\frac{\pi}{2} f_3$	1.6 uV/rtHz	1.7 uV/rtHz
Total LF Noise (RMS)			195 uVrms	585 uVrms
Total HF Noise (due to V_N)			271 uVrms	286 uVrms

Notes:

f_2 = signal BW = 50Hz

f_3 = closed loop BW = 17 kHz

Signal-to-Noise Ratio

	Without post LPF	With post LPF
LF Noise	195 μ Vrms	195 μ Vrms
HF Noise	271 μ Vrms	46 μ Vrms
Total Noise	333 μ Vrms	200 μ Vrms
SNR	89.5 dB	94 dB

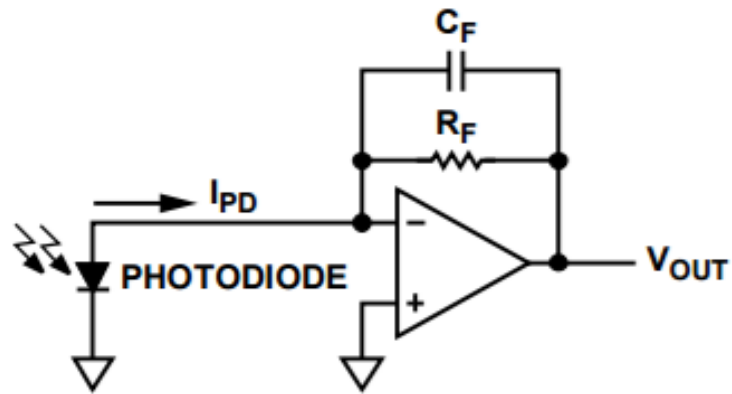

Without LPF

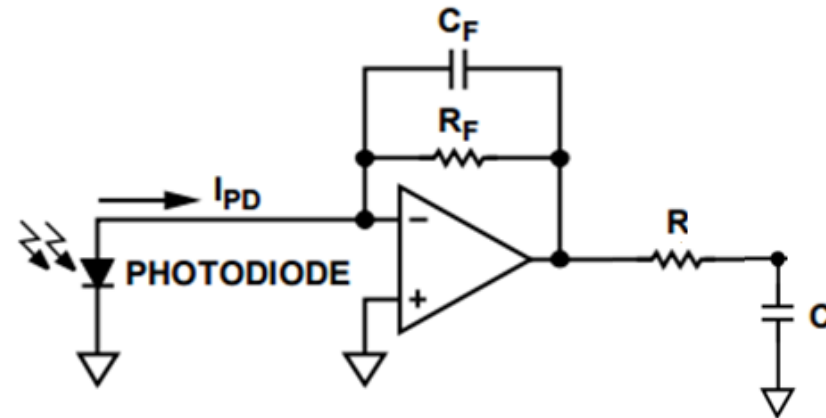

With LPF



AHEAD OF WHAT'S POSSIBLE™

Measurement Challenges

TIPS AND CONSIDERATION

Guarding

- ▶ Surround insulation of high impedance node with another conductor that is driven to the guard voltage (at or close to the high impedance node potential)
- ▶ Better layout yields better performance over time and environmental conditions

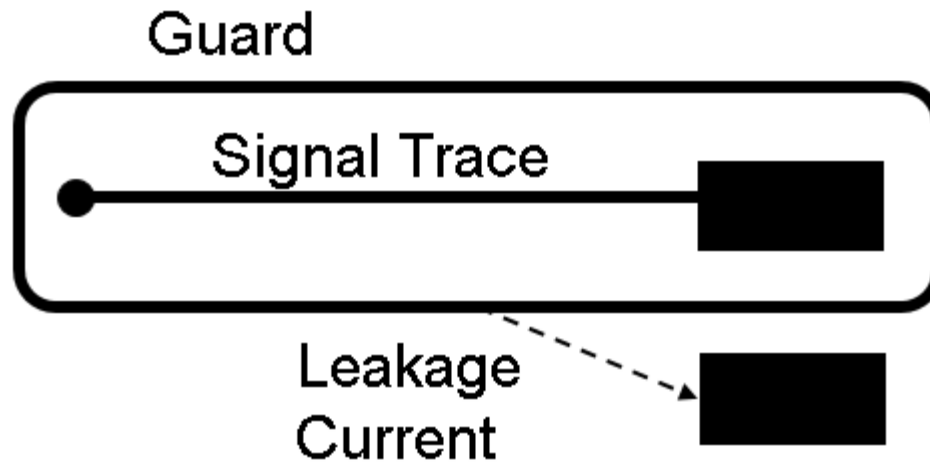

Guarding

▶ Guard rings

- Guard surface leakage
- Remove solder mask / silkscreen on guard rings/traces
 - Avoid moisture absorption
- Needs to be driven by an amplifier at the same potential as the input (e.g. a buffer)

▶ Guard plane

- Guards through the bulk of PCB

▶ Via fence

- Guards lateral leakage paths

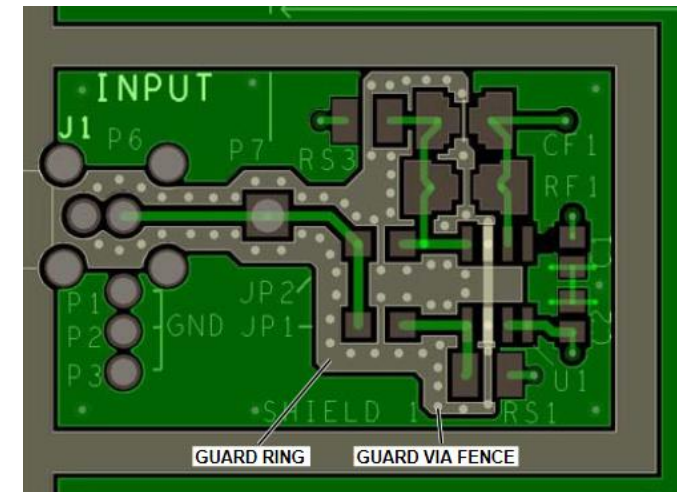
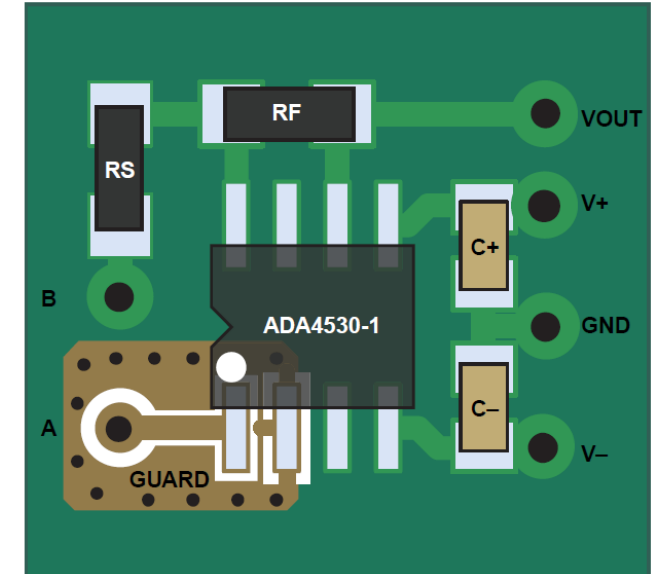
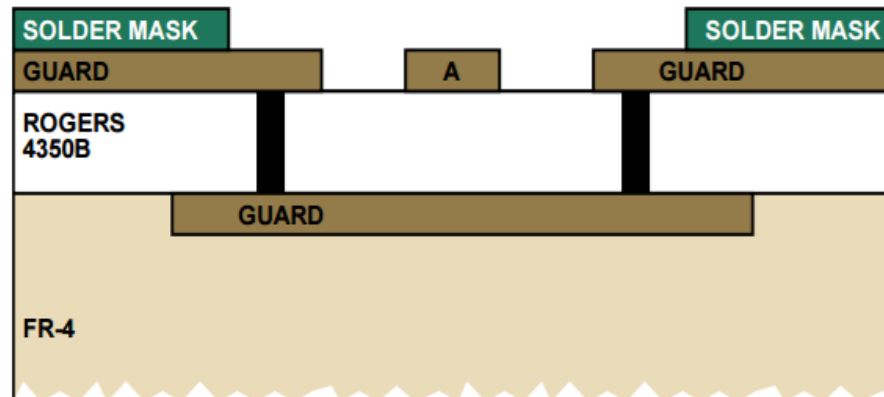

Example of guarding

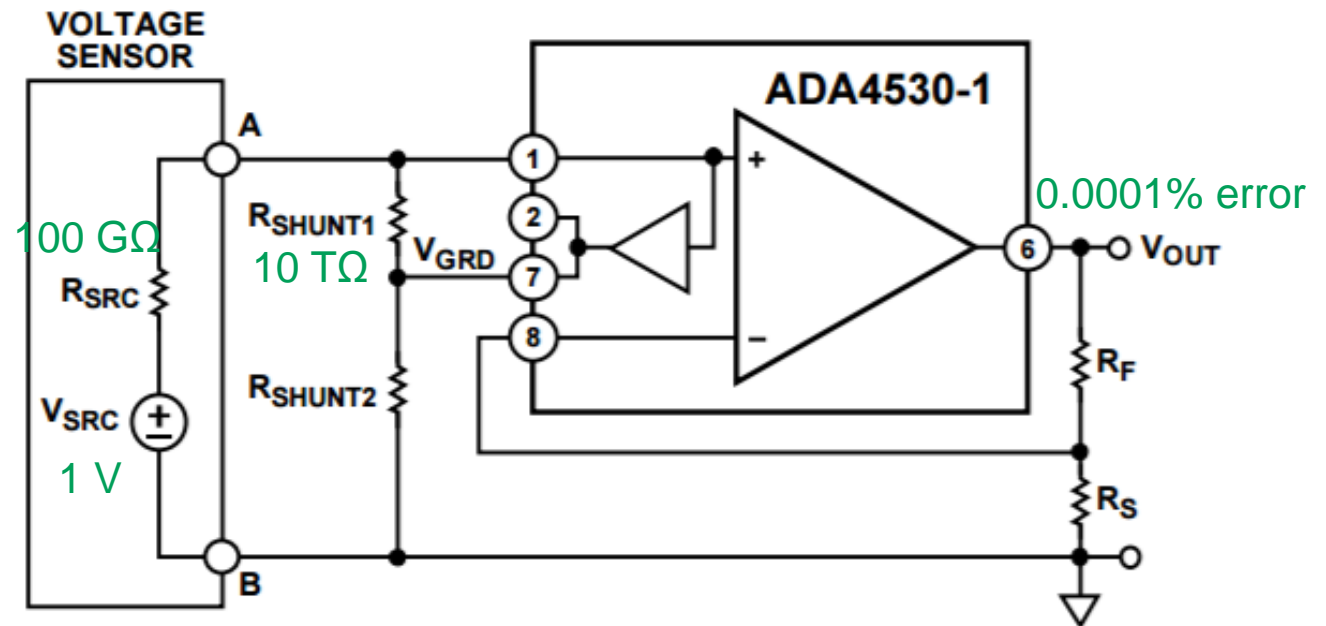
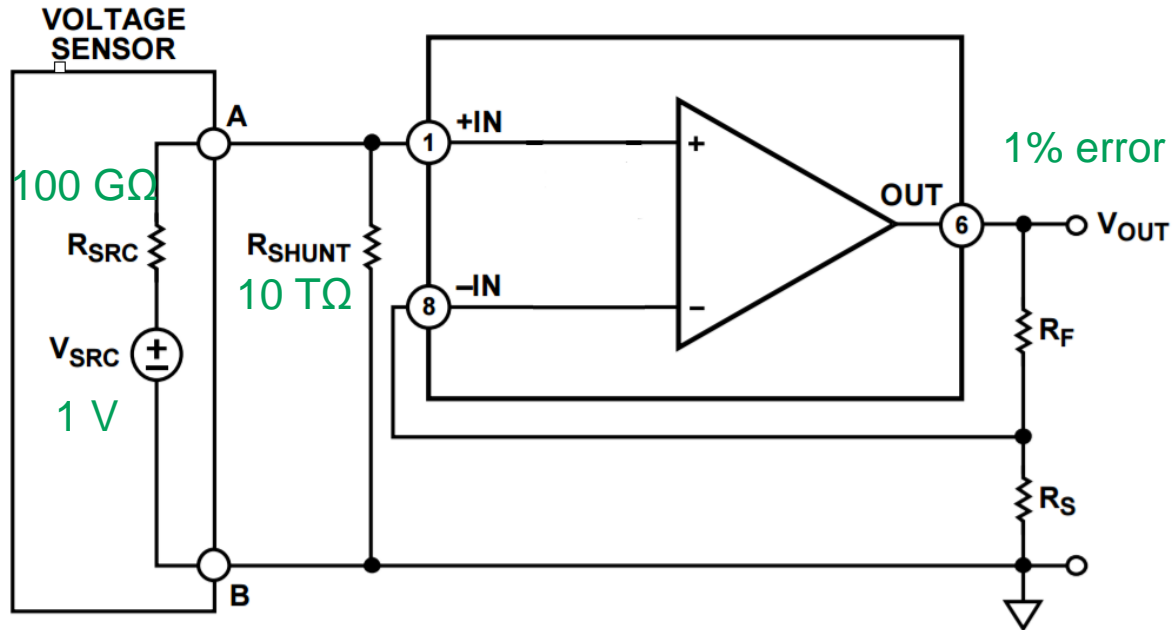

Contamination

Contamination Sources Act as Weak Battery

- Solder flux residue
- Dust and other particulate accumulation
- Dirt
- Body Oils
- Saline moisture

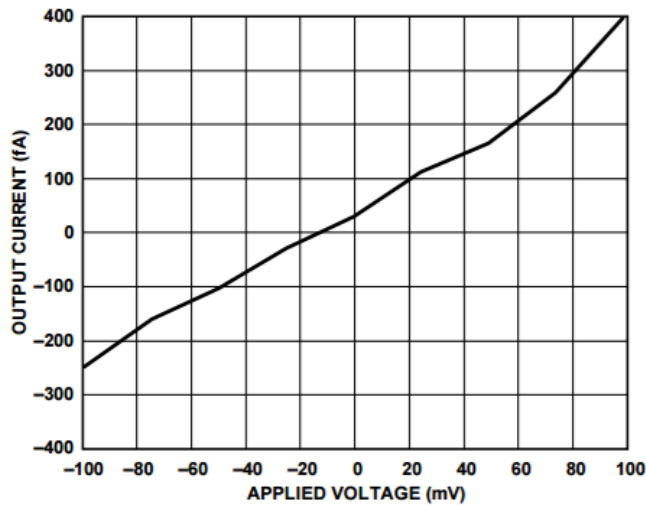

Current to Voltage Response of RMA Contaminated Insulation

$$V_{\text{BATT}} = 15\text{mV}$$
$$R_{\text{BATT}} = 300\text{ G}\Omega$$

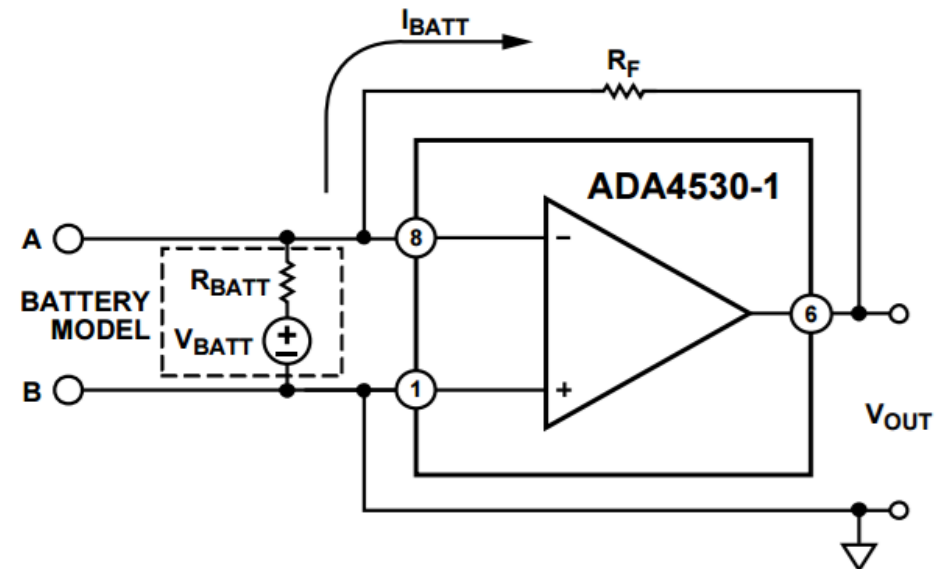

Cleaning and handling is as important as the circuit design itself!

Contamination

- ▶ Washing/cleaning is recommended after assembly
- ▶ Moisture reduces insulation properties of PCB and cables
 - Choose appropriate materials and perform measurements in controlled environments
 - Bake after wash to eliminate moisture absorption
- ▶ NO No-clean solder paste

Material	Moisture Absorption (%)
Hi Pref FR-4	0.50
Nearly pure PTFE	0.02

Source: Rogers Corp.

Table 7. Recommended Cleaning Procedures for Different Solder Paste Material

Solder Paste Type	Solder Paste Part Number	Recommended Cleaning Procedure ¹
RMA	AIM RMA258-15R	15 min clean time in an ultrasonic cleaner with fresh IPA, followed by 1.5 hours of bake time at 125°C
Water Soluble	SAC305 Shenmao	1.5 hours clean time in an ultrasonic cleaner with fresh IPA, followed by 1.5 hours of bake time at 125°C
No Clean	SAC 305 AMTECH LF4300	3 hours clean time in an ultrasonic cleaner with fresh IPA, followed by 3 hours of bake time at 125°C

¹ Bake time was not optimized and was set equal to the cleaning time.

- ▶ UG-865 for an effective cleaning procedure

Dielectric Absorption

- ▶ Dielectric Relaxation / Soakage
- ▶ Delay in polarization of dielectric molecules in response to an electric field
- ▶ Commonly observed in
 - Capacitors
 - Multilayer PCBs
- ▶ Often modeled as an RC in parallel with the “ideal” capacitor
- ▶ Dominates settling time in electrometer circuits

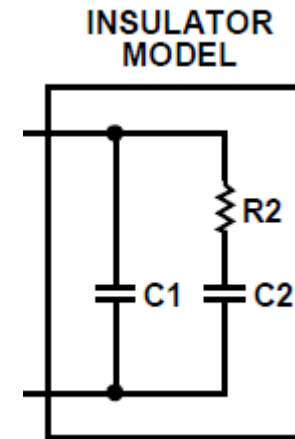

Dealing with Dielectric Absorption in PCBs

- ▶ PTFE, Rogers 4350B

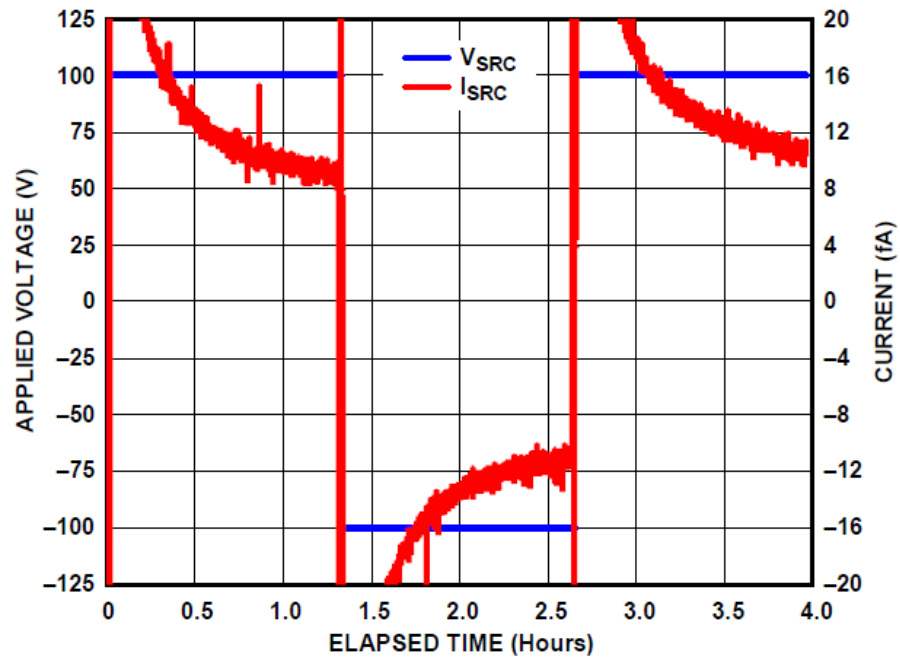

Glass epoxy (FR-4)

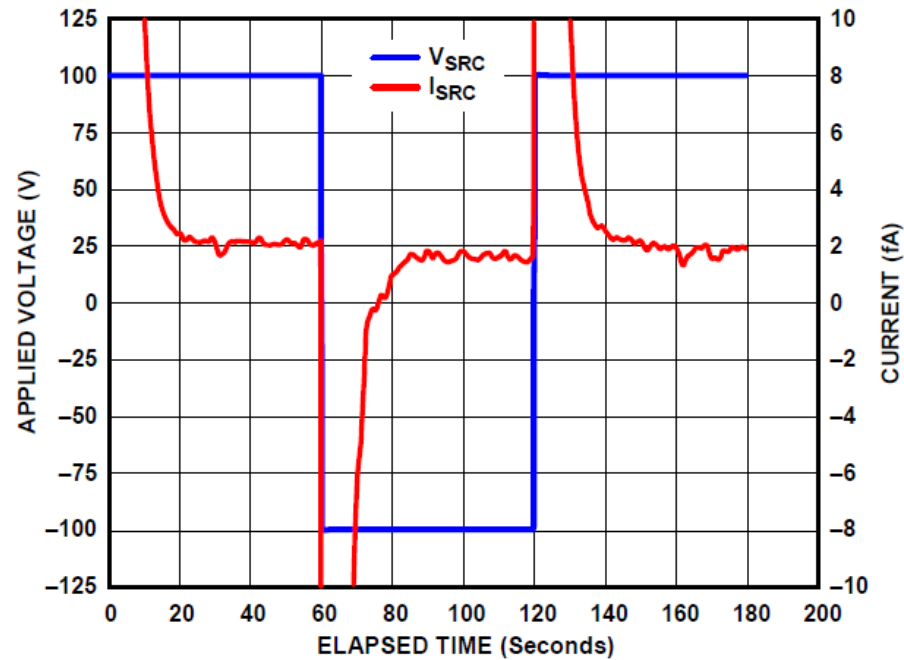

Rogers 4350B

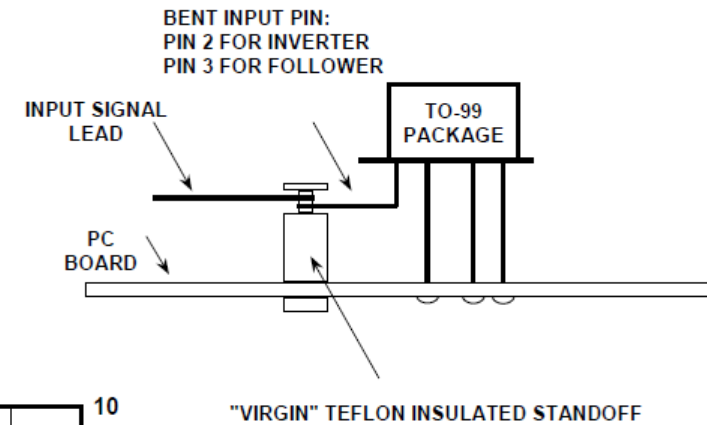

Shielding

- ▶ Shields help keep stray fields away from sensitive nodes
- ▶ Shields should be grounded when exposed to operators for safety

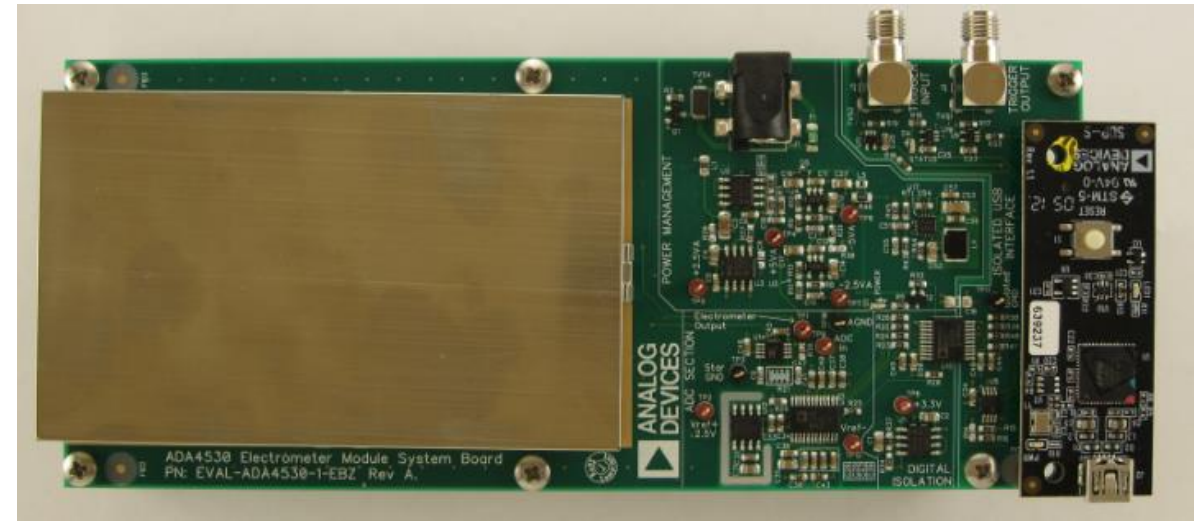

Cabling and connectors

- ▶ Best: Use triax
 - Has an extra inner conductor to guard signal
- ▶ BNC, SMA and coaxial cables are OK as long as there is very little potential difference between center conductor and shield
 - Cost effective
 - Some RF materials (PTFE) have good low-leakage, low DA properties
- ▶ Cable tie down to reduce triboelectric effects

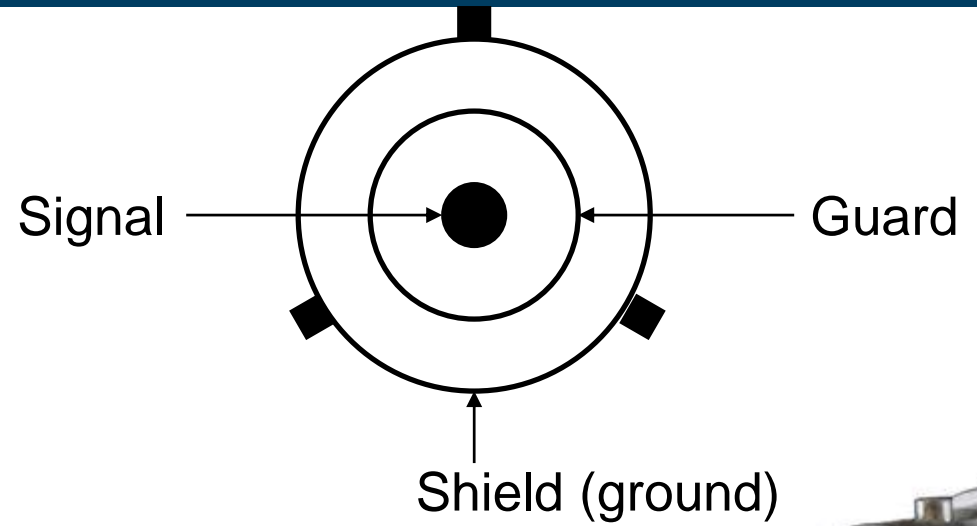

Summary

- ▶ Design of low-level current measurement hardware requires attention to many details!

Problem	Source	Solution
PCB leakage	Moisture and contamination	Dust covers/shielding
	Solder flux contamination	Avoid no-clean solder paste; wash and bake
Dielectric absorption	Charge trapped in dielectrics	Use PTFE / Rogers 4350B dielectric material
Cable leakage	Poor quality insulation between conductors	Use PTFE-insulated cables or triax cables/connectors
Extrinsic Noise	E/M fields, Powerline interference	Shielding and guarding
	Mechanical vibrations, triboelectricity	Cable tie-downs

- ▶ A femtoammeter measurement platform solves many problems and enables quick prototyping



AHEAD OF WHAT'S POSSIBLE™

Femtoampere Measurement Platform

MAKING IT EASY FOR DESIGN-INS

Ultra High Sensitivity Femtoammeter Module

- ▶ Development module for sensors with low-level current output
 - Direct interface to sensors like photodiodes, faraday cups through SMA connector
- ▶ Features
 - **<10fA sensitivity** with 10GΩ transimpedance
 - 500pA measurement range
 - Shielding
 - Isolation with **ADuM3151**
 - Femtoampere input bias op amp
 - **ADA4530-1**
 - 24-bit resolution ADC
 - **AD7172-2**
 - USB interface to PC via SDP
 - Simple power supply: 9VDC input
 - **ADP7118, ADP2442, ADP7182**
 - Measurement synchronization
 - Trigger in/out signals

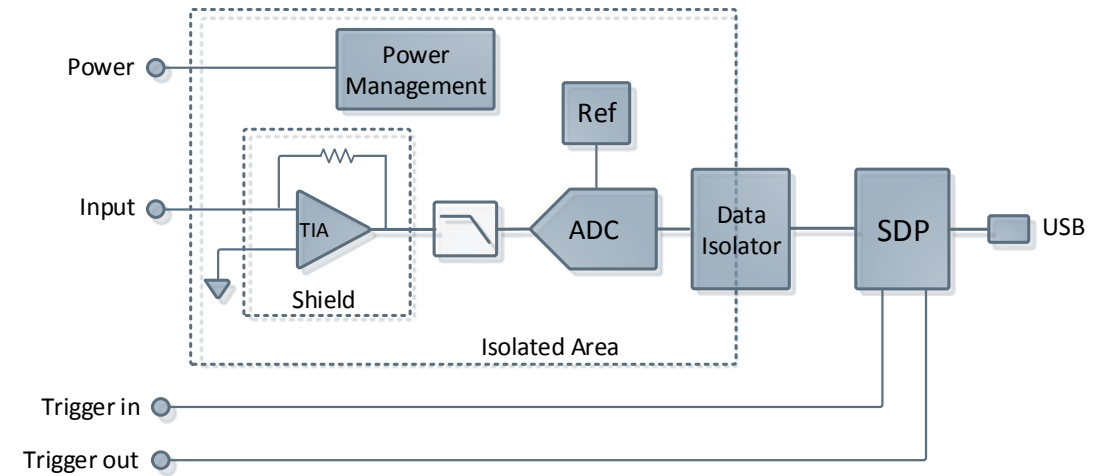
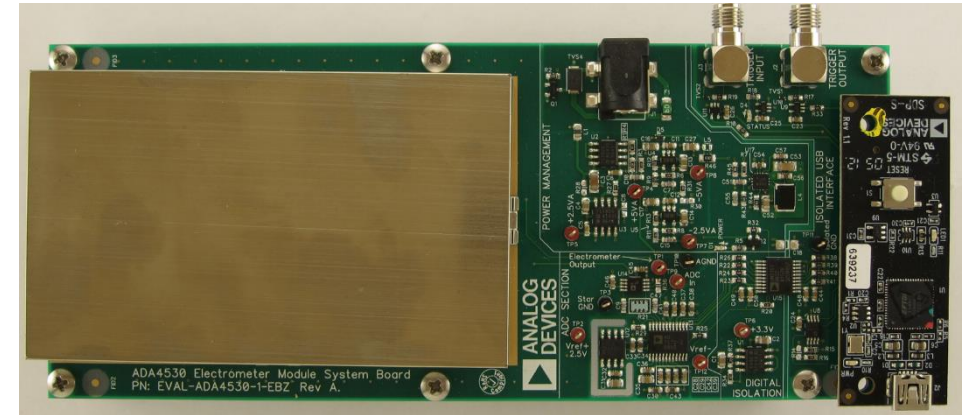

Ultra High Sensitivity Femtoammeter Module

- ▶ Allows user to directly connect sensor to the board in their own application environment
- ▶ Designed for real-world applications

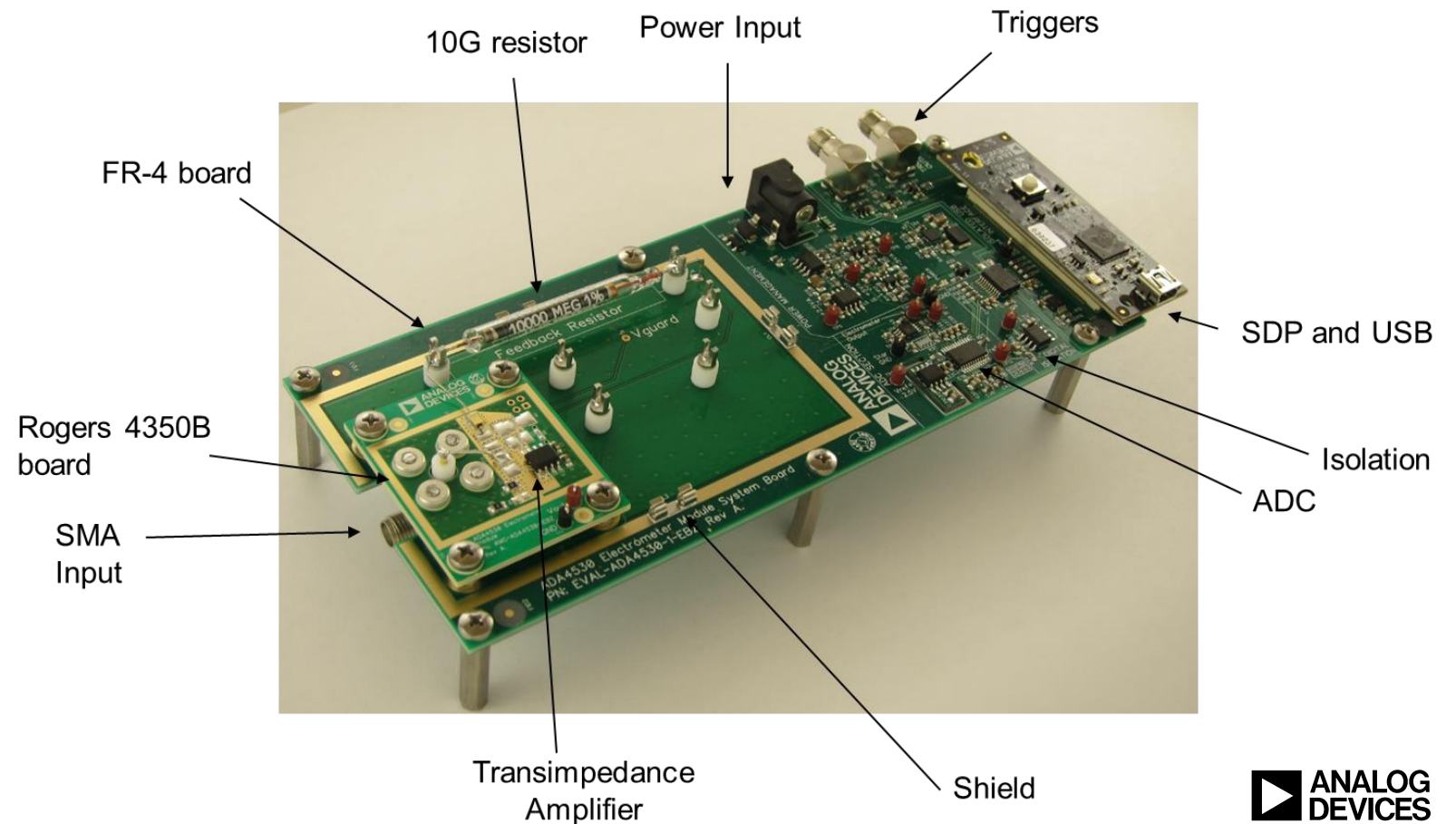
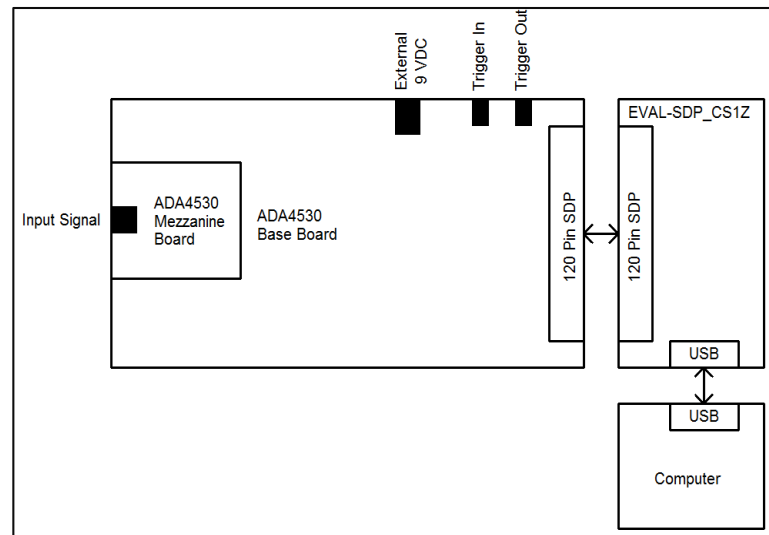

CN-0407: Ultra High Sensitivity Femtoampere Measurement Platform



Circuit Note CN-0407

Circuits from the Lab® Reference Designs

Circuits from the Lab® reference designs are engineered and tested for quick and easy system integration to help solve today's analog, mixed-signal, and RF design challenges. For more information and/or support, visit www.analog.com/CN0407.

Devices Connected/Referenced	
ADA4530-1	Femtoampere Input Bias Current Electrometer Amplifier
AD7172-2	Low Power, 24-Bit, 31.25 kSPS, Sigma-Delta ADC with True Rail-to-Rail Buffers
ADR4525	Ultralow Noise, High Accuracy, Voltage Reference
ADP2442	36 V, 1 A, Synchronous, Step-Down, DC-to-DC Regulator with External Clock Synchronization
ADG1419	2.1 Ω On Resistance, $\pm 15\text{V}/\pm 12\text{V} \pm 5\text{V}$, iCMOS SPDT Switch
ADP7118	20 V, 200 mA, Low Noise, CMOS LDO Linear Regulator
ADP7182	-28 V, -200 mA, Low Noise, Linear Regulator
ADuM3151	3.75 kV, 7-Channel, SPI Isolator Digital Isolators for SPI

Ultrahigh Sensitivity Femtoampere Measurement Platform

EVALUATION AND DESIGN SUPPORT

Circuit Evaluation Boards

[CN-0407 Circuit Evaluation Board \(EVAL-CN0407-SDPZ\)](#),

Consists of Two Boards

[Low Leakage Mezzanine Board \(EVAL-CN0407-1-SDPZ\)](#)

[Data Acquisition Board \(EVAL-CN0407-2-SDPZ\)](#)

[System Demonstration Platform \(EVAL-SDP-CS1Z\)](#)

Design and Integration Files

[Schematics](#), [Layout Files](#), [Bill of Materials](#)

CIRCUIT FUNCTION AND BENEFITS

The system functional diagram in Figure 1 is a precision analog front end for measurement of current down to the femtoampere range. This industry-leading solution is ideal for chemical analyzers and laboratory grade instrument where an ultrahigh sensitivity analog front end is required for signal conditioning current output sensors such as photodiodes, photomultiplier tubes, and Faraday cups. Applications that can use this solution include mass spectrometry, chromatography, and coulometry.

The EVAL-CN0407-SDPZ provides a reference design for real-world application by partitioning the system into a low-leakage mezzanine board and a data acquisition board. The input signal conditioning is implemented with the ADA4530-1 on the mezzanine board. The ADA4530-1 is an electrometer-grade amplifier with ultralow input bias current of 20 fA maximum at 85°C. A guard buffer is integrated on the chip to isolate the input pins from leakage to the printed circuit board (PCB). The default amplifier configuration is in the transimpedance mode with a 10 G Ω glass resistor and a metal shield that prevents leakage current from entering any of the high impedance paths on the board. In addition, the mezzanine board includes unpopulated resistor and capacitor pads to allow prototyping with surface-mount feedback resistors as well as other input configurations.

The data acquisition board uses an AD7172-2 24-bit Σ - Δ analog-to-digital-converter (ADC) and is powered from a single 9 V dc supply. The on-board supply generates all necessary voltages required to power both boards. The board connects to a PC via the SDP-S board (EVAL-SDP-CS1Z) and uses digital isolation to prevent noise from the USB bus or ground loops from degrading low current measurements.

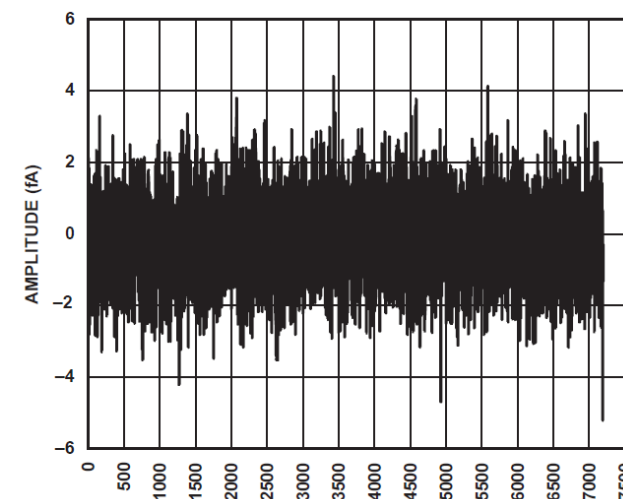
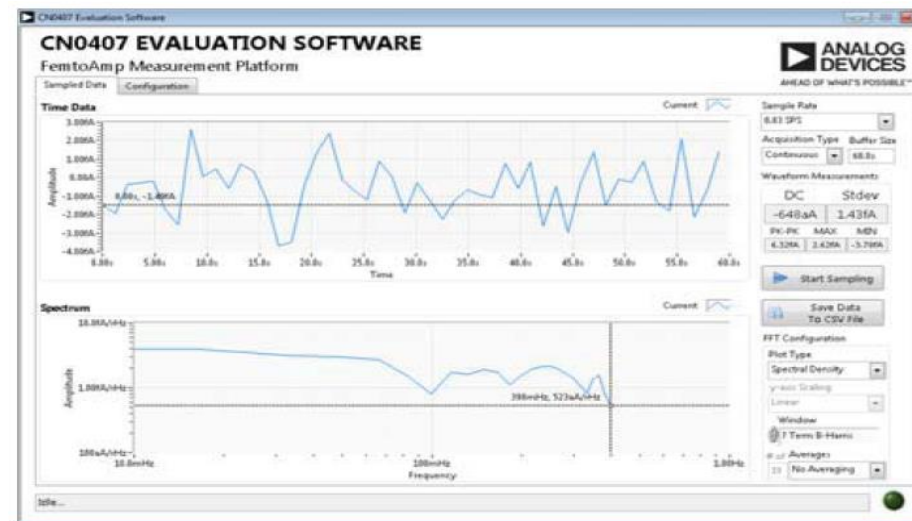

Board Noise (sampled data with an open input at 0.83sps for 120min)



AHEAD OF WHAT'S POSSIBLE™



AHEAD OF WHAT'S POSSIBLE™

The Photoelectric Effect Demo

AS A LOW LEAKAGE MEASUREMENT CASE STUDY

Photoelectric Effect

- ▶ Emission of electrons when light is shone onto a photoemissive material

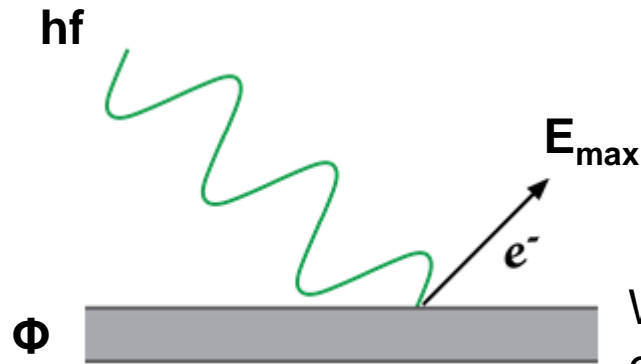

$$E_{\max} = hf - \Phi$$

Work function, Φ : min energy required to eject an electron from the surface of the material

- ▶ Sensor:

- ▶ Phototube (vacuum tube with an anode and a cathode)
- ▶ Cesium Antimony
- ▶ What is the work function of the phototube?

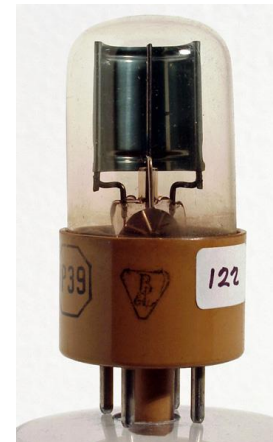

Demo: Using ADA4530-1 to Accurately Measure Current down to 0 fA



Simplified Diagram

ADA4530-1 Femtoammeter Module

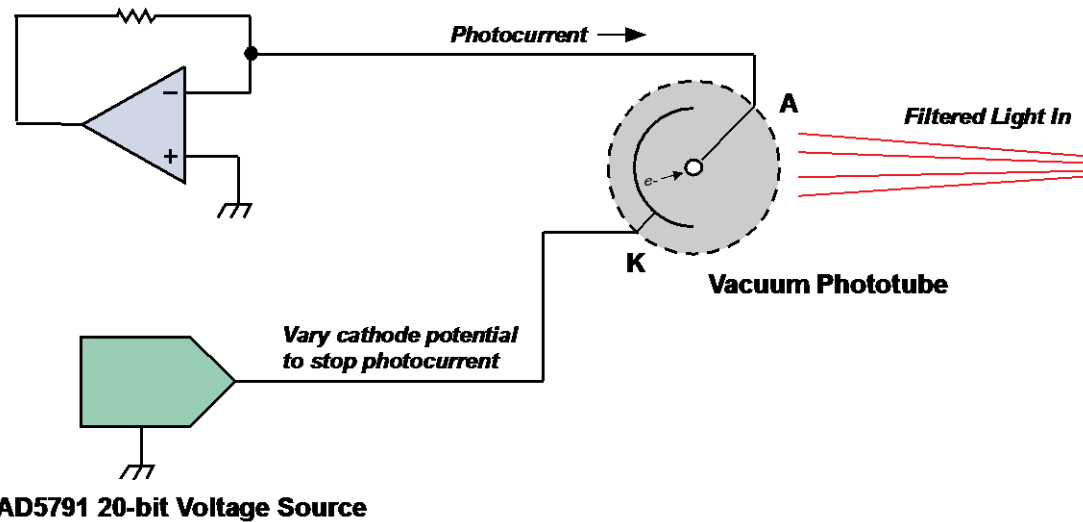

- ▶ Use a phototube with Cesium Antimony material
- ▶ Provide a light source
- ▶ Measure the photocurrent
- ▶ Apply a voltage (stopping potential) opposing the electron flow to measure kinetic energy
- ▶ Calculate work function $E_{\max} = q \times V_{\text{STOP}} = hf - \Phi$

Demo Measurement Results

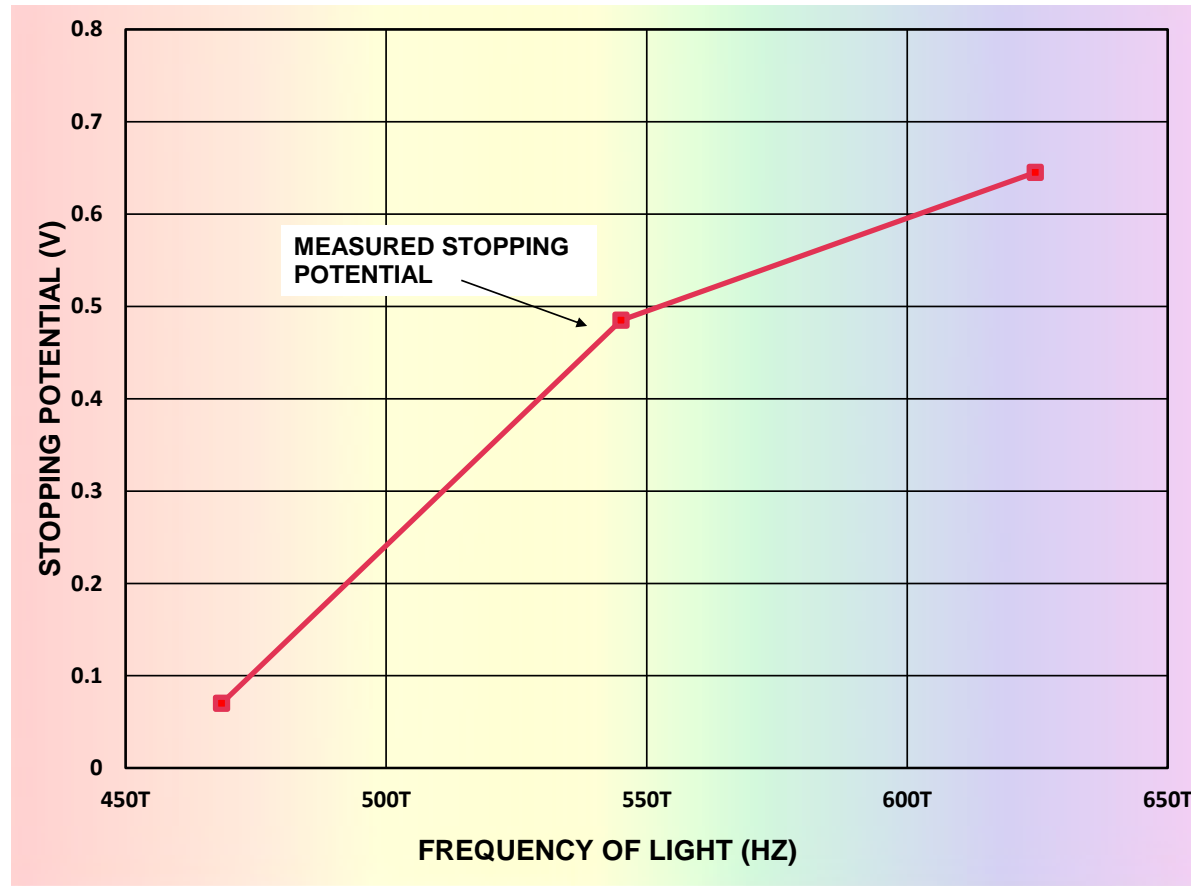

- ▶ The stopping potential varies with light frequency as expected
- ▶ Work function, Φ , measured to be 1.86eV

Conclusion / Takeaways

Things we learned

- ▶ It is important to minimize output error and maximize SNR to achieve high sensitivity current measurements.
 - ▶ Minimizing output error demands a high precision amplifier with low I_B and drift.
 - ▶ Maximizing SNR requires careful selection of gain component.
- ▶ Design of low-level current measurement hardware requires attention to unique considerations.
 - ▶ Board leakage, contamination, moisture, dielectric absorption, cabling, etc. can contribute to significant measurement errors.
 - ▶ Best practices with guarding, shielding, cleaning/handling, appropriate board/solder material and cabling mitigate the errors.
- ▶ ADI's ultra high sensitivity femtoampere measurement platform provides out of the box direct connection to sensors in your application environment.

Useful links

- ▶ ADA4530-1 front end electrometer (<http://www.analog.com/media/en/technical-documentation/data-sheets/ADA4530-1.pdf>)
- ▶ CN-0407: Ultrahigh Sensitivity Femtoampere Measurement Platform (www.analog.com/CN0407)
- ▶ User Guide: UG-865 (http://www.analog.com/media/en/technical-documentation/user-guides/ADA4530-1R-EBZ_UG-865.pdf)
- ▶ App Note: AN1373 (<http://www.analog.com/media/en/technical-documentation/application-notes/AN-1373.pdf>)

Thank You For Watching!

View Additional Webcasts at
www.analog.com/Webcasts

Ask Questions on EngineerZone
ez.analog.com/Webcasts

Search for ADI Parts on Mouser
Mouser.com