



**SERIAL**  
新曄集團

# Single Cell Battery Fuel Gauge

**SS Jung**  
**ss.jung@serialsystem.com**

**2018 2Q**

Your Integral Component to Success

- Battery Characteristic
- What is Fuel Gauge?
- What is TI's Fuel Gauging Technology?
- TI Single Cell Fuel Gauge Solution



**SERIAL**  
新擘集團

# Li-Ion Battery Characteristic

Your Integral Component to Success

- XsYp
  - “X” number of cells in series
    - Voltage of pack is “X” \* Vcell
  - “Y” number of cells in parallel
    - Capacity of pack is “Y” \* Capacity of 1 cell

## Pack Configurations Example

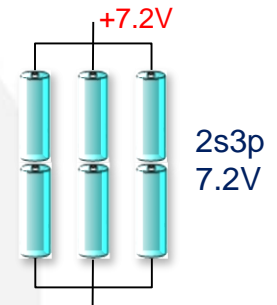
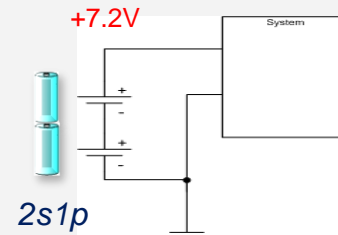
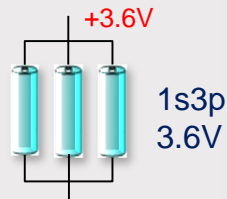
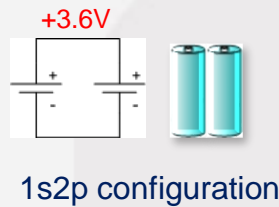

# Terminology – Design Capacity

- Battery label says: 3200/3300mAh (min/typ)

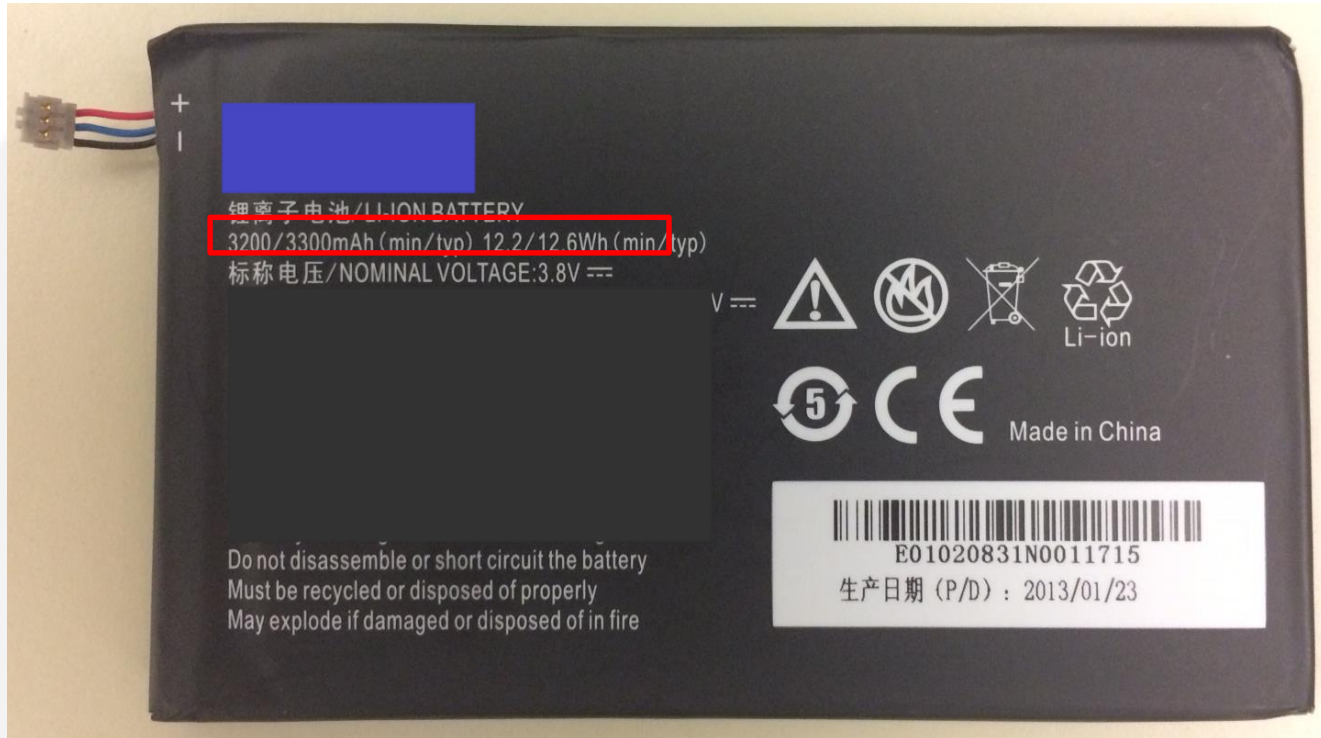

- We say “Design Capacity = 3300mAh”

- “C-rate” or “Hour rate” is a way of expressing current relative to nominal battery capacity.
- If nominal capacity is 3300mAh...
  - A discharge rate of “1C” means use a current of 3300mA.
    - In theory, it would take 1 hour to discharge at this rate, but actually it will probably be shorter.
  - A charge rate of “C/2” means use a current of 1650mA.
    - This is also considered a “2-hour rate”.

# OCV Curve

## Capacitor

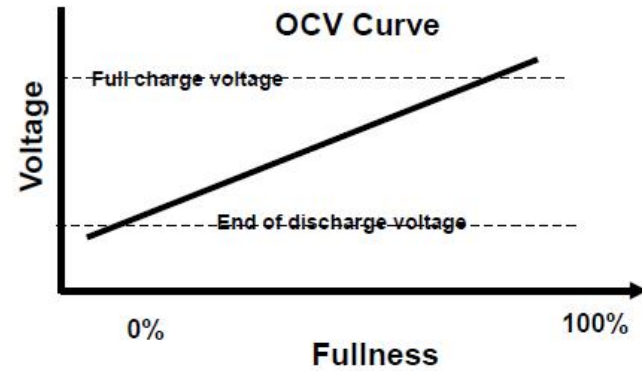
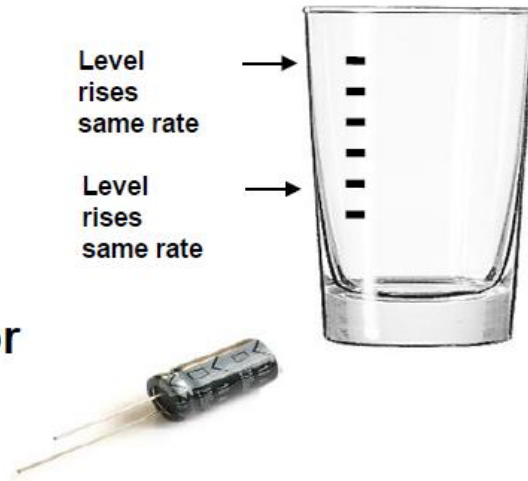

## Battery

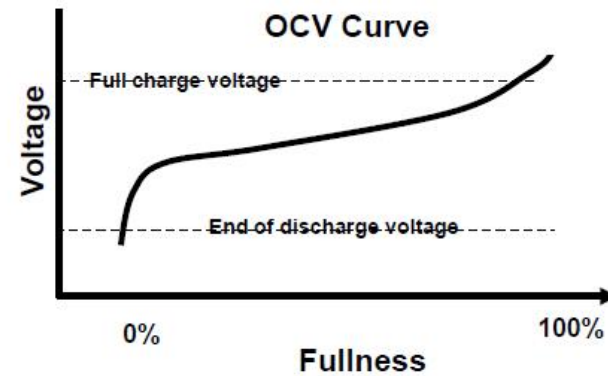
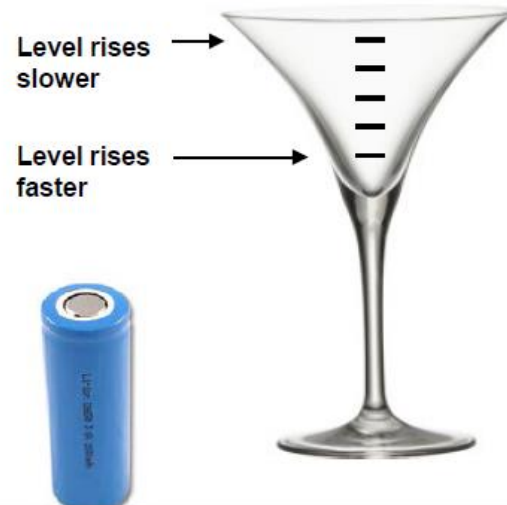

# Simple Battery Model

- A battery is a complex electro-chemical system, but let's start with a simplistic model...

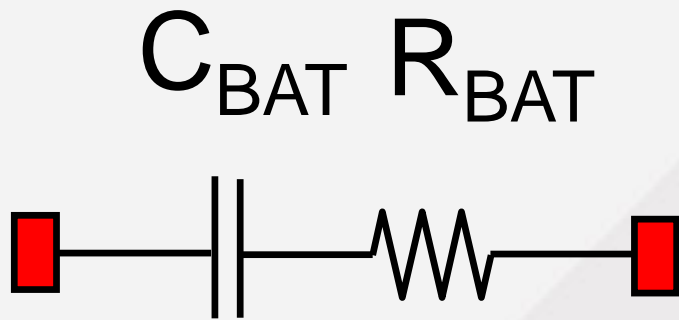

## Constant current discharge, transient effect

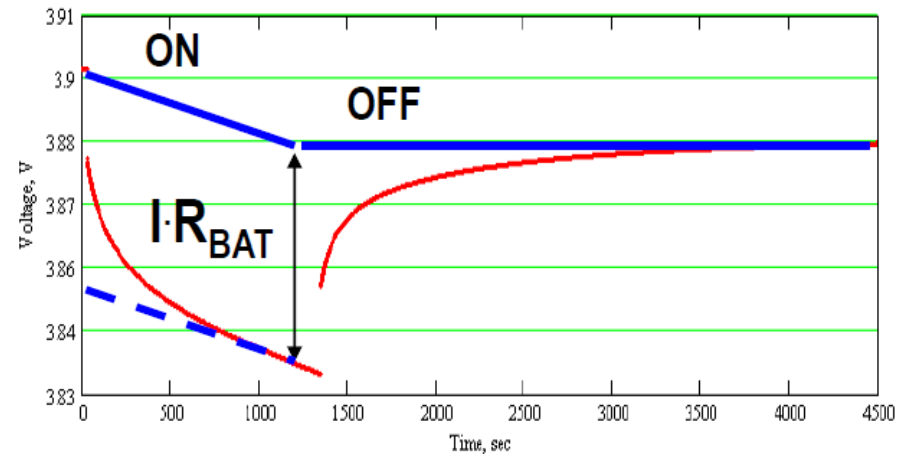

- Capacitor
- - - Capacitor + resistor
- Battery

# IR drop: different usable capacities

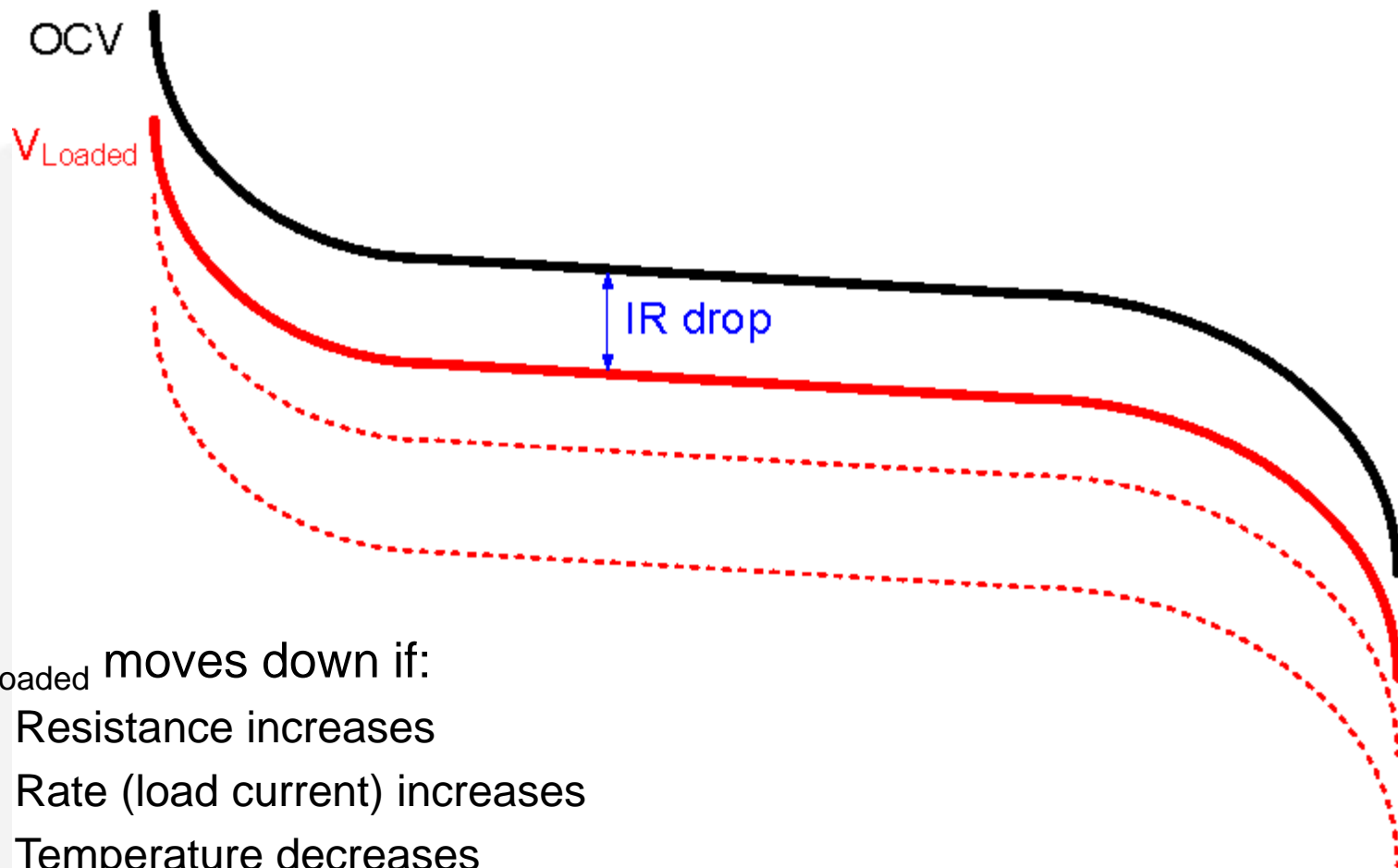

- $V_{\text{Loaded}}$  moves down if:
  - Resistance increases
  - Rate (load current) increases
  - Temperature decreases



**SERIAL**  
新擘集團

# What is Fuel Gauge

Your Integral Component to Success

# Fuel Guage Concept

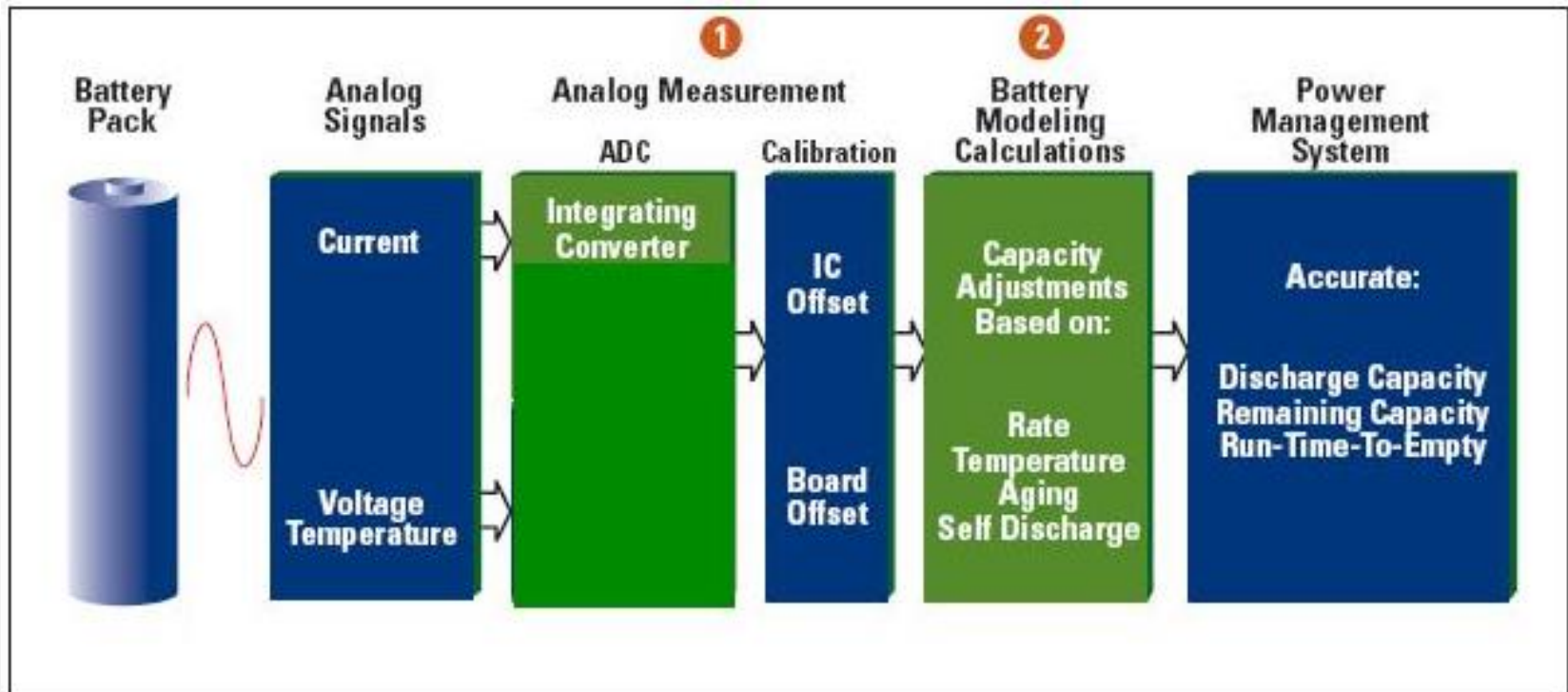

# Broad Applications with Battery Gauges



### PE – Core

- Smartphones
- Notebooks
- Tablets



### PE – Non Core

- Sports Cam
- Wireless Speaker
- Wireless Headset
- Gaming
- MiFi
- Powerbank
- Wearable
- BT accessories



### Industrial

- EPOS
- Handheld meters
- eBike
- Drone
- Home automation
- Portable Medical
- Robotic
- Super cap
- UPS - ESS



# What can a gauge do?

- Predict the future
- Enhance safety
- Be a “black box”
- Extend run-time
- Extend lifetime of a battery

# What can a gauge do?

- Predict the future
  - capacity (% or mAh or mWh)
  - run-time predictions (in minutes)
  - charge time predictions
- Enhance safety
- Be a “black box”
- Extend run-time
- Extend lifetime of a battery

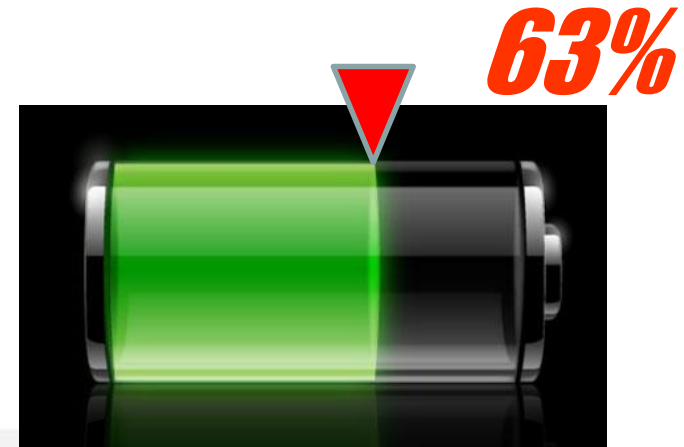

***Run Time 6:27***

***2701 mWh***

***730 mAh***

# What can a gauge do?

- Predict the future
- **Enhance safety**
  - Controls protection functions inside the battery pack
- Be a “black box”
- Extend run-time
- Extend lifetime of a battery

# What can a gauge do?

- Predict the future
- Enhance safety
- **Be a “black box”**
  - record usage conditions
  - assist with warranty analysis and troubleshooting
  - assist with supplier quality improvement
- Extend run-time
- Extend lifetime of a battery

# What can a gauge do?

- Predict the future
- Enhance safety
- Be a “black box”
- **Extend run-time**
  - confidently use all available battery capacity with no surprises
  - no unused capacity due to over-cautious shutdown conditions
- Extend lifetime of a battery

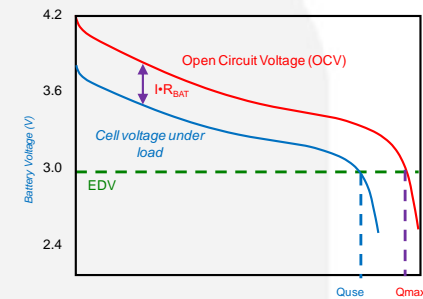
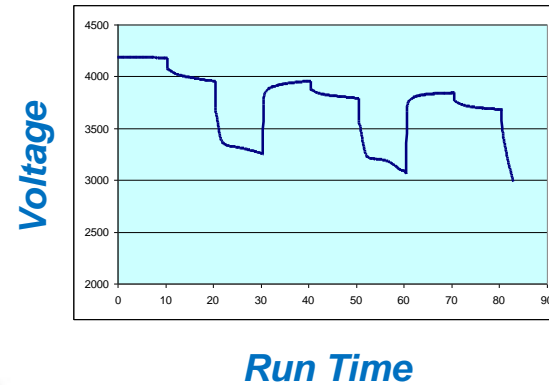

# What can a gauge do?

- Predict the future
- Enhance safety
- Be a “black box”
- Extend run-time
- **Extend lifetime of a battery**
  - get more cycles from a battery
  - uses dynamic learning and battery modeling to control healthy, safe, and fast charging

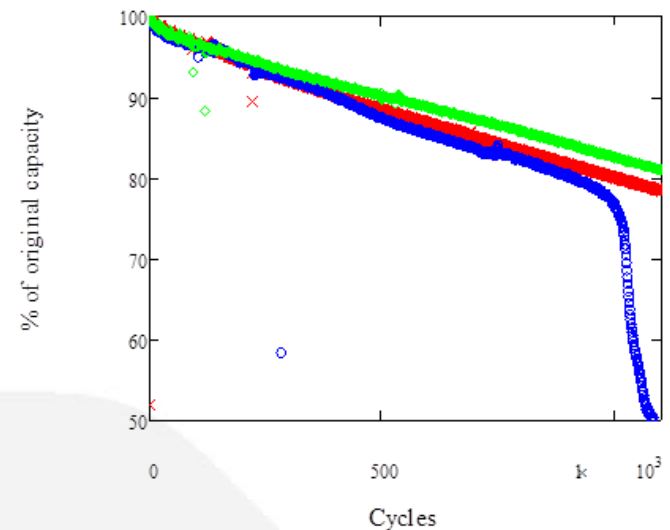

# What else can a gauge do...

- Authentication
  - Ensure only safe/authorized packs are used
- State of Health
  - Objectively tell user when a battery is at end of life
- Traceability
  - Store serial numbers, production information, and more inside gauge's flash memory
- Instrumentation in system
  - Highly accurate voltage, current, and temperature measurements
  - Useful for system characterization and production tests
- Assist with power management
  - Control charger or load
  - Recommend maximum current that won't crash battery
  - Allow host to remain in low power state and wait for interrupts



**SERIAL**  
新擘集團

# What is TI's Fuel Gauging Technology?

Your Integral Component to Success

- OCV – open circuit voltage
  - relaxed or predicted voltage with no load
- DOD – depth of discharge
  - 0% is charged to the brim, 100% is completely empty of energy
  - Does not depend on load or temperature or system characteristics
- RM – Remaining Capacity in mAh
  - Usable capacity of the battery from current DOD to empty
- FCC – Full Charge Capacity in mAh
  - Usable capacity of the battery from full to empty
- SOC – state of charge, 0% - 100%
  - Full and empty points depend on the system
  - Can change with load and temperature
  - $SOC = RM / FCC$
- EDV – End of Discharge Voltage

# Usable Capacity

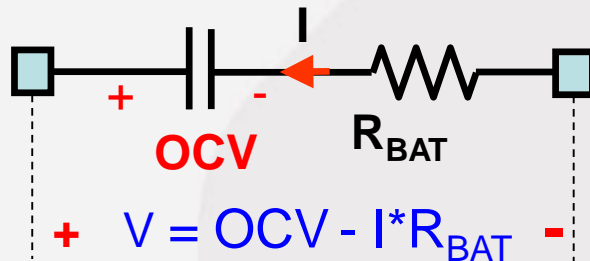
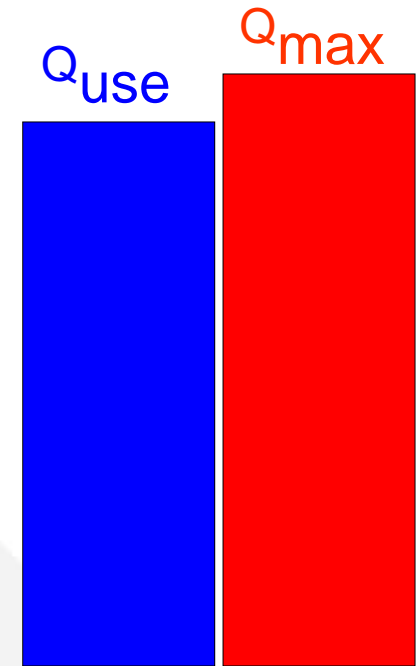
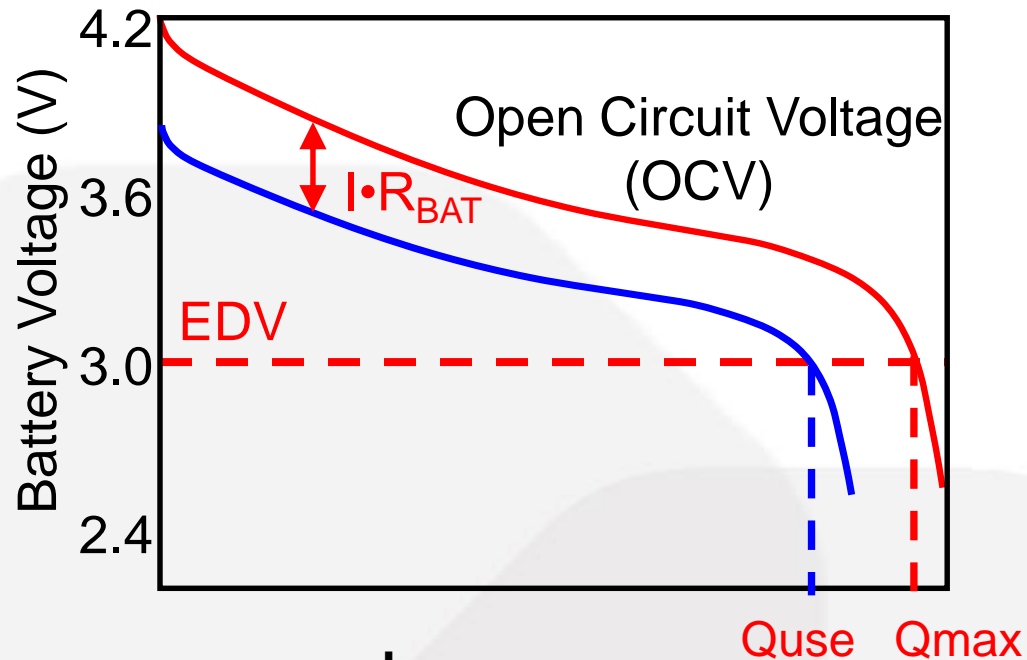

- EDV will be reached earlier for higher discharge current.
- Usable capacity  $Q_{use} < Q_{max}$

# What Does A Fuel Gauge Do?

Which route is the battery taking?

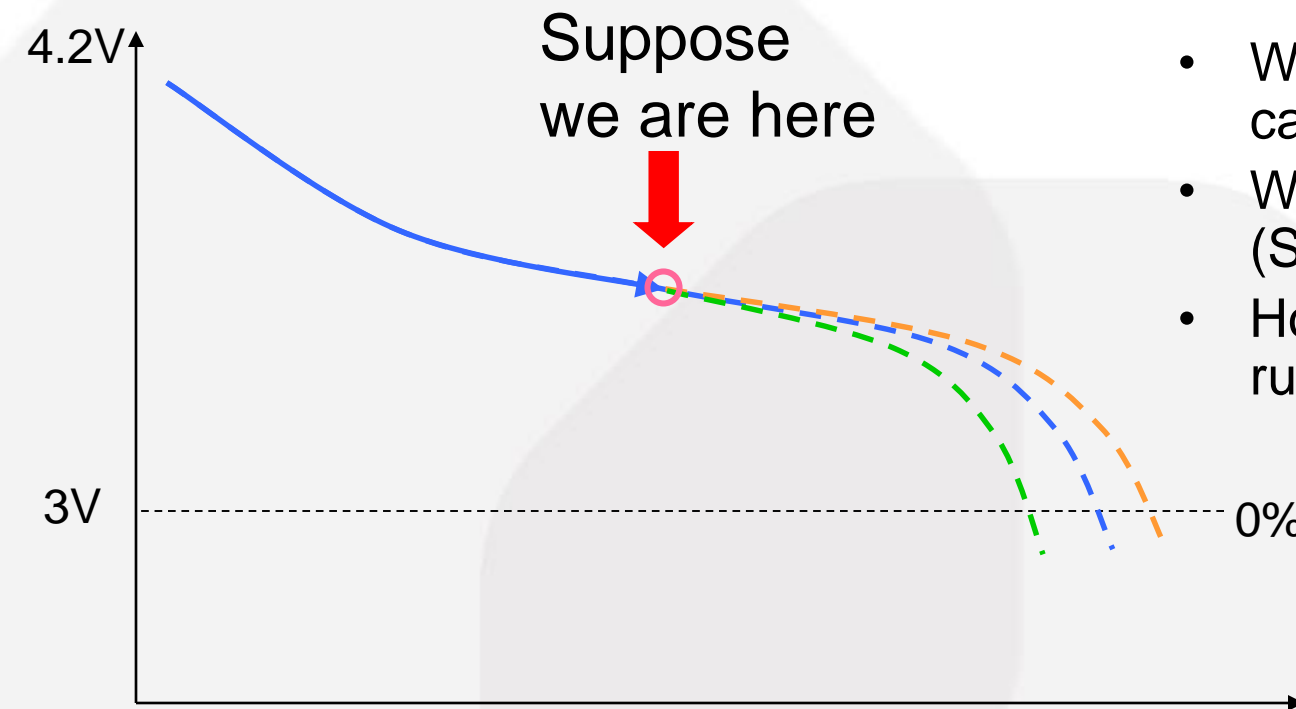

- What is the remaining capacity at current load?
- What is the State of charge (SOC)?
- How long can the battery run?

# Current Integration Based Fuel-gauging

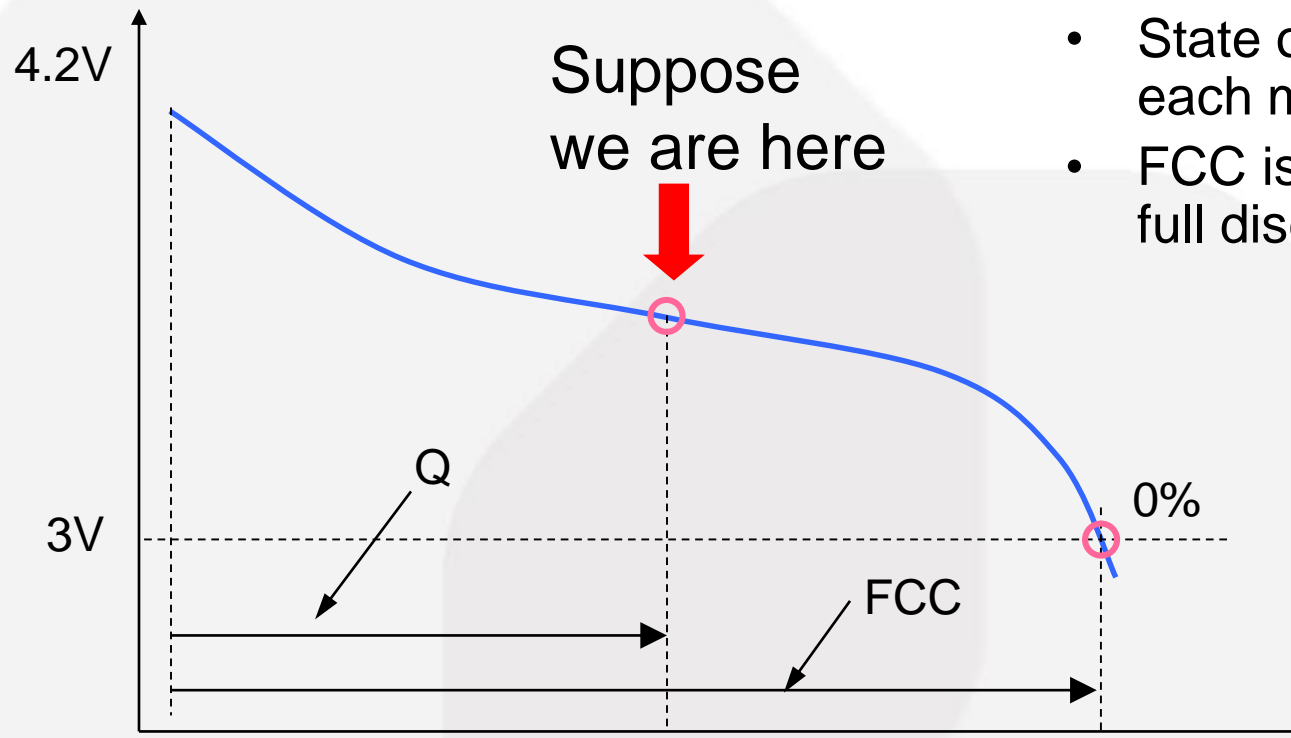

- Battery is fully charged
- During discharge capacity is integrated
- State of charge (SOC) at each moment is  $RM/FCC$
- FCC is updated every time full discharge occurs

$$RM = FCC - Q$$

$$SOC = RM/FCC$$

# Learning Before Fully Discharged

– fixed voltage thresholds

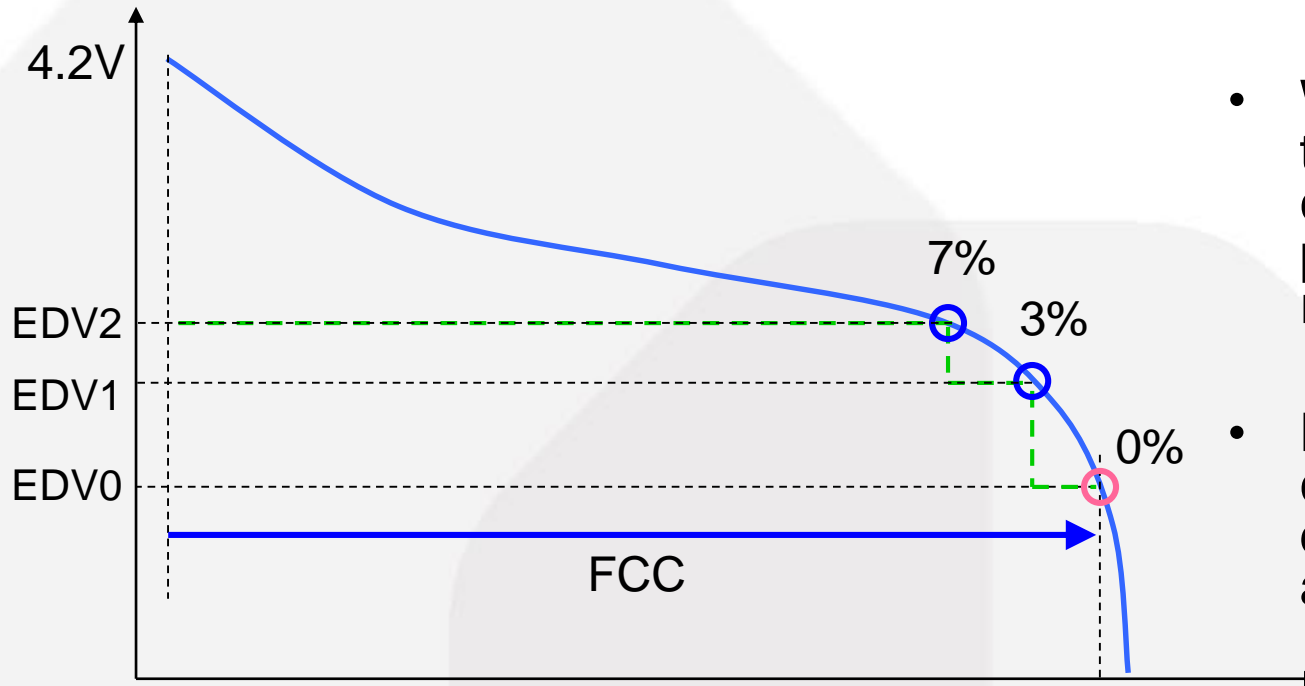

- It is too late to learn when 0% capacity is reached → Learning FCC before 0%
- We can set voltage threshold that correspond to given percentage of remaining capacity
- However, true voltage corresponding to 7% depends on current and temperature

# Learning before fully discharged

## with current and temperature compensation

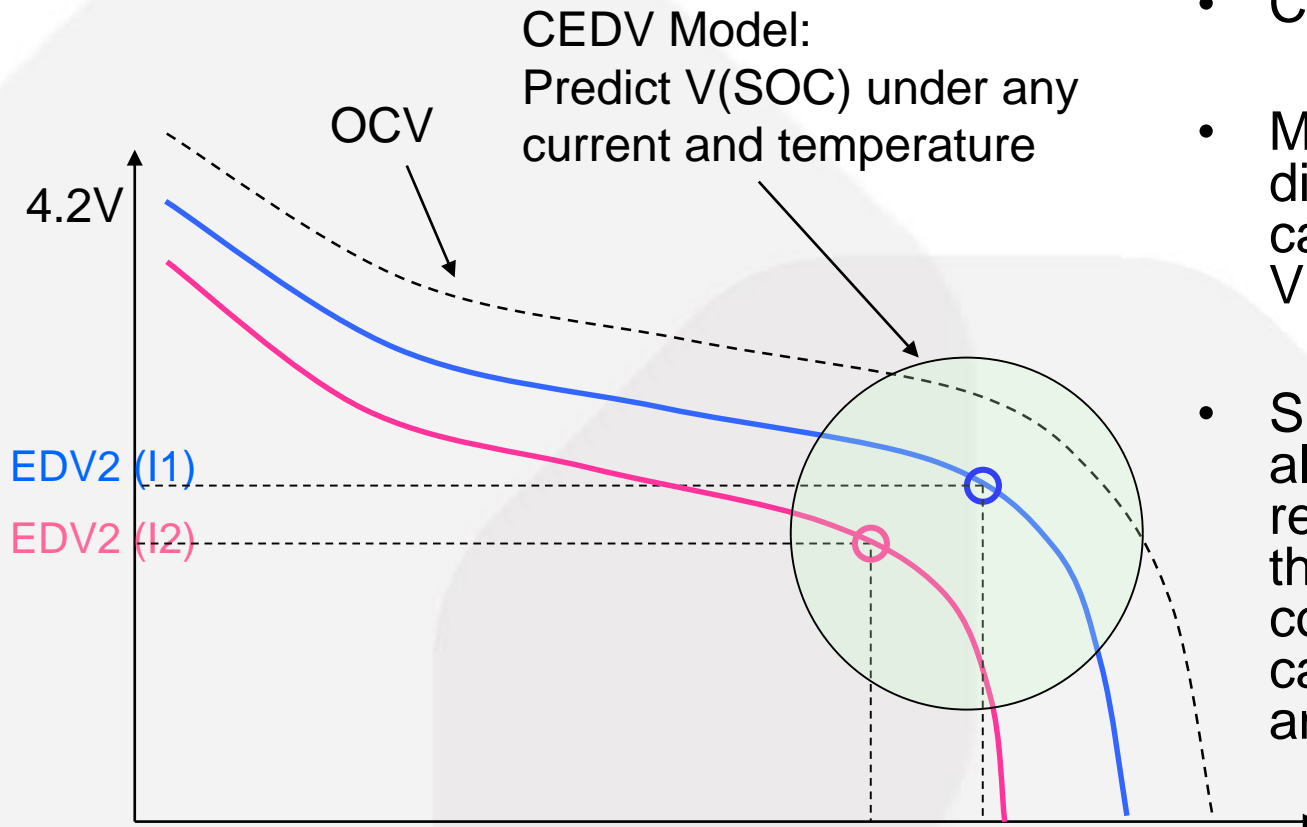

- CEDV
- Modeling last part of discharge allows to calculate function  $V(\text{SOC}, I, T)$
- Substituting  $\text{SOC}=7\%$  allows to calculate in real time CEDV2 threshold that corresponds to 7% capacity at any current and temperature

# CEDV Model Visualization

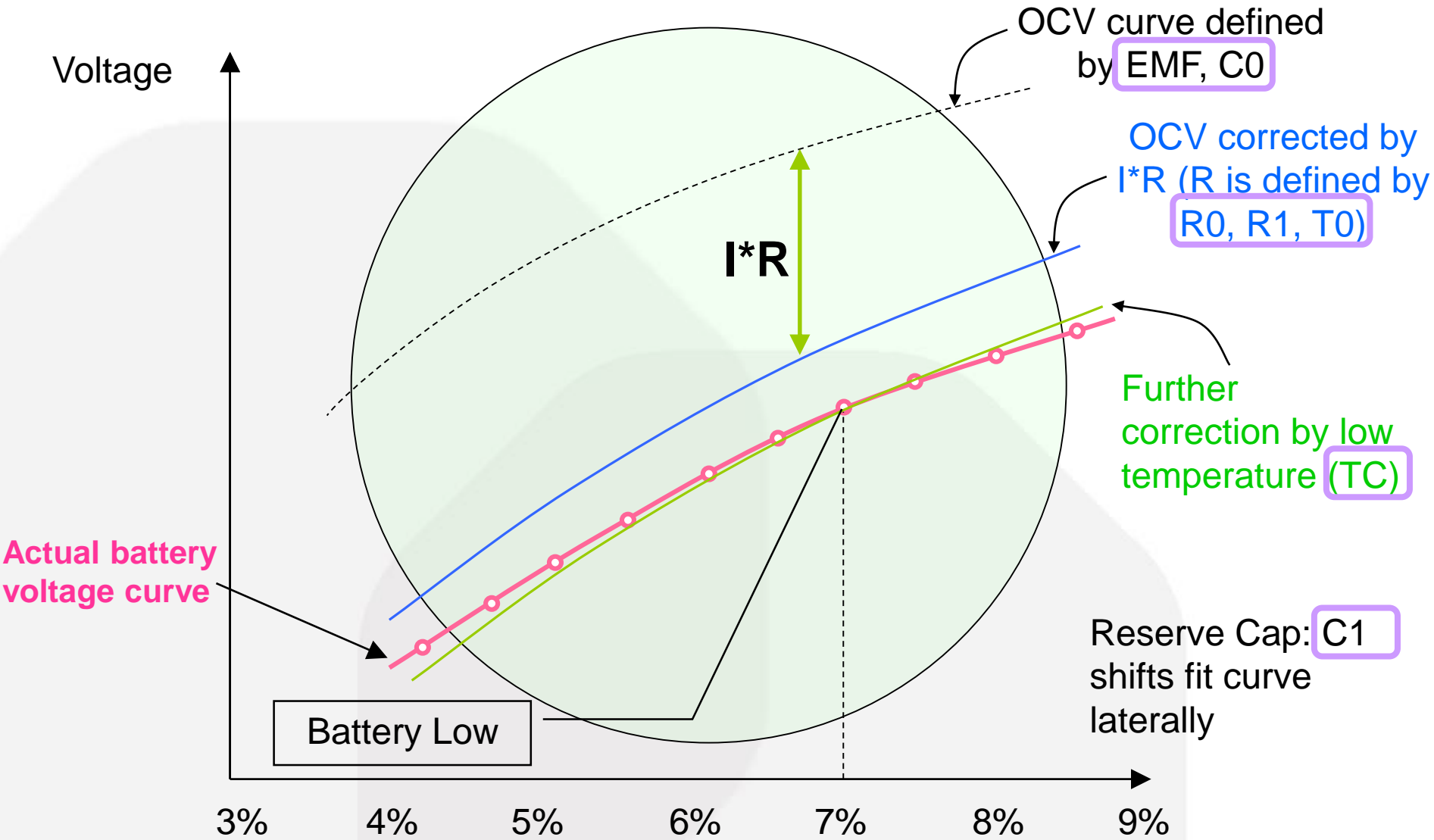

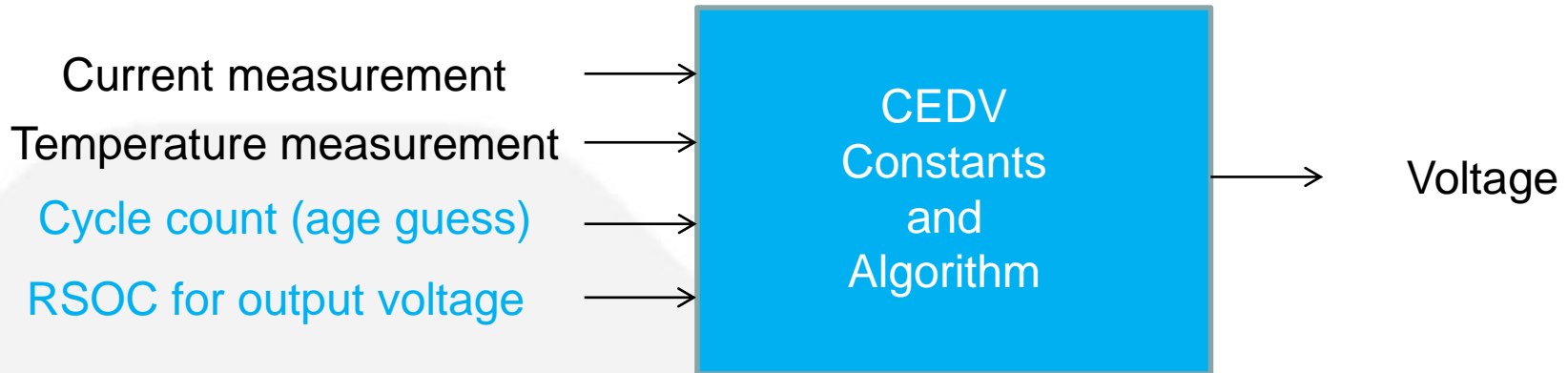

The seven constants describe:

- OCV curve shape
- Temperature effect on OCV
- Resistance
- Temperature effect on resistance
- Low temperature effects
- Aging properties
- Reserve capacity

## Cell Voltage Measurement

- Measures cell voltage
- Advantage: Simple
- Not accurate over load conditions

## Coulomb Counting

- Measures and integrates current over time
- Affected by cell impedance
- Affected by cell self discharge
- Standby current
- Cell Aging
- Must have *full to empty* learning cycles
- Must develop cell models that will vary with cell maker
- Can count the charge leaving the battery, but won't know remaining charge without complex models
- Models will become less accurate with age

## Impedance Track™

- **Directly measures effect of discharge rate, temp, age and other factors by learning cell impedance**
- **Calculates effect on remaining capacity and full charge capacity**
- **No host algorithms or calculations**

# OCV (open circuit voltage)

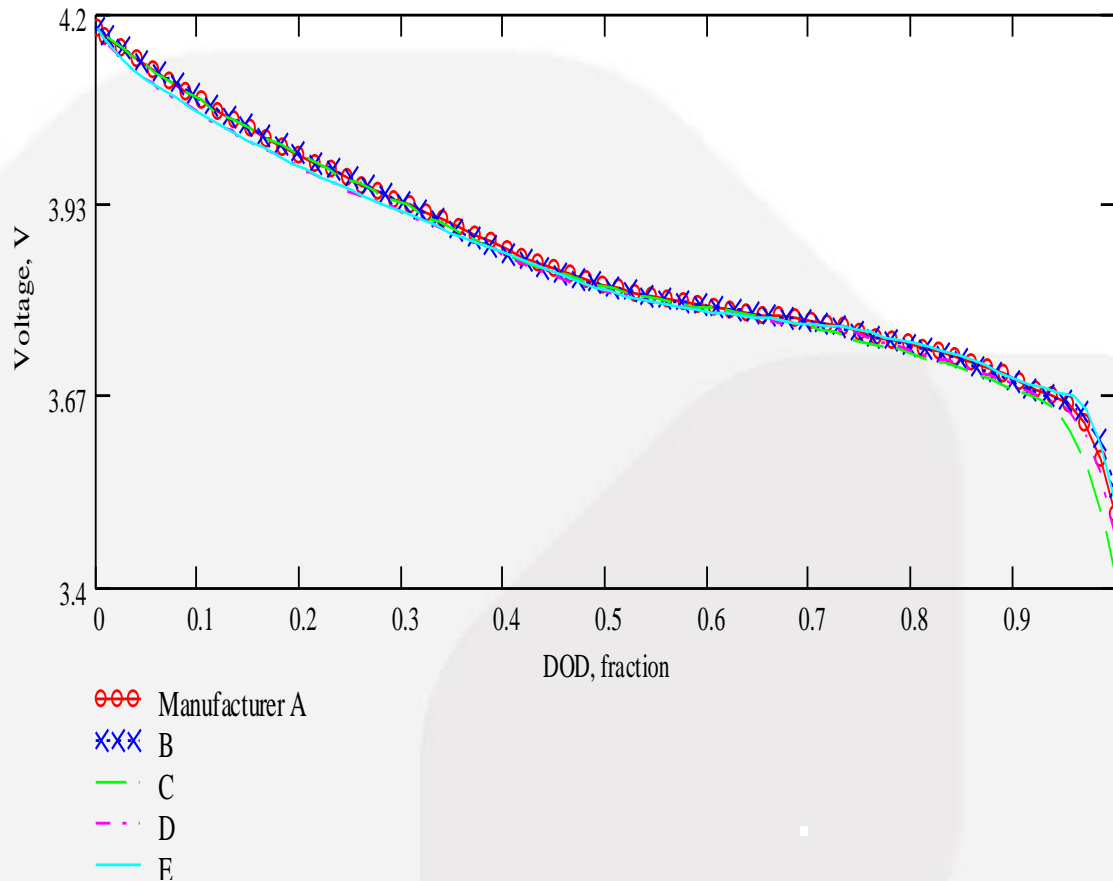

- OCV profiles can be very consistent if base electrode chemistry is the same
- Most voltage deviations from average are below 5mV
- Average DOD prediction error based on average voltage/DOD dependence is below 1.5%
- Same OCV database can be used with batteries produced by different manufacturers as long as base chemistry is same
- Generic database allows **significant simplification of fuel-gauge implementation** at user side

# Measuring OCV

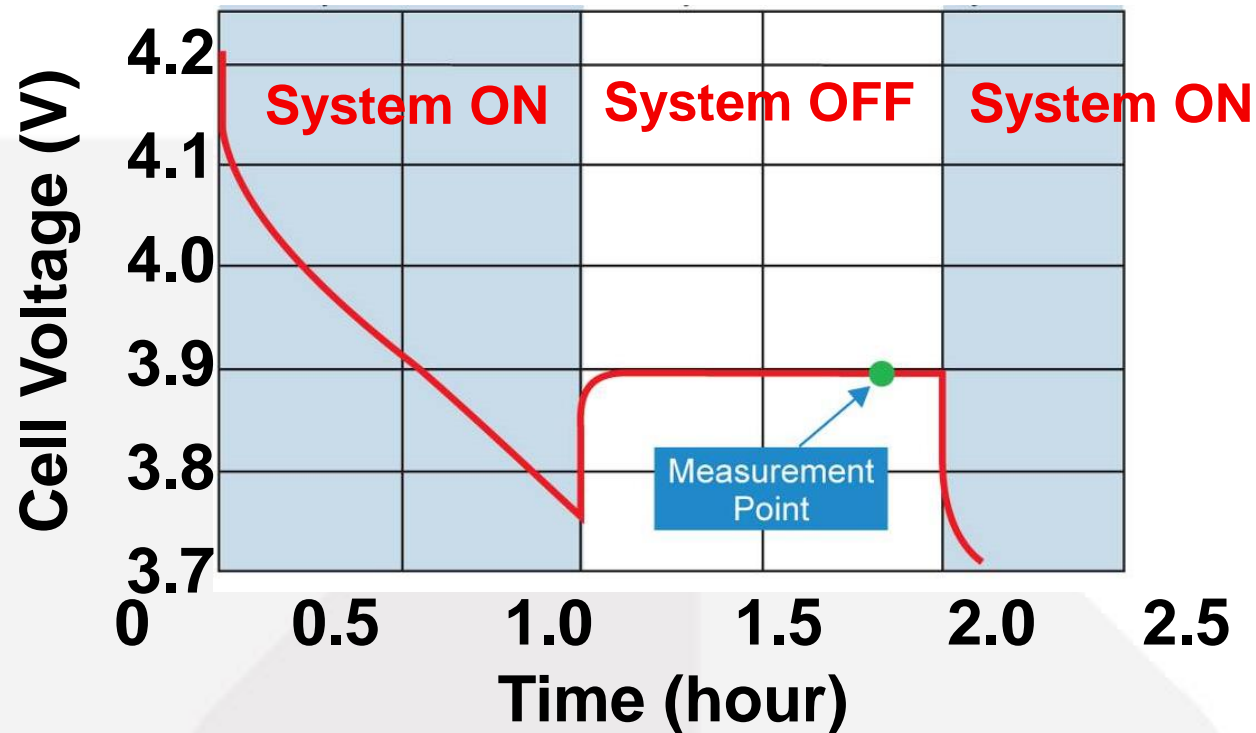

- OCV measurement allows SOC with 0.1% max error
- Self-discharge estimation is eliminated

# Qmax updating

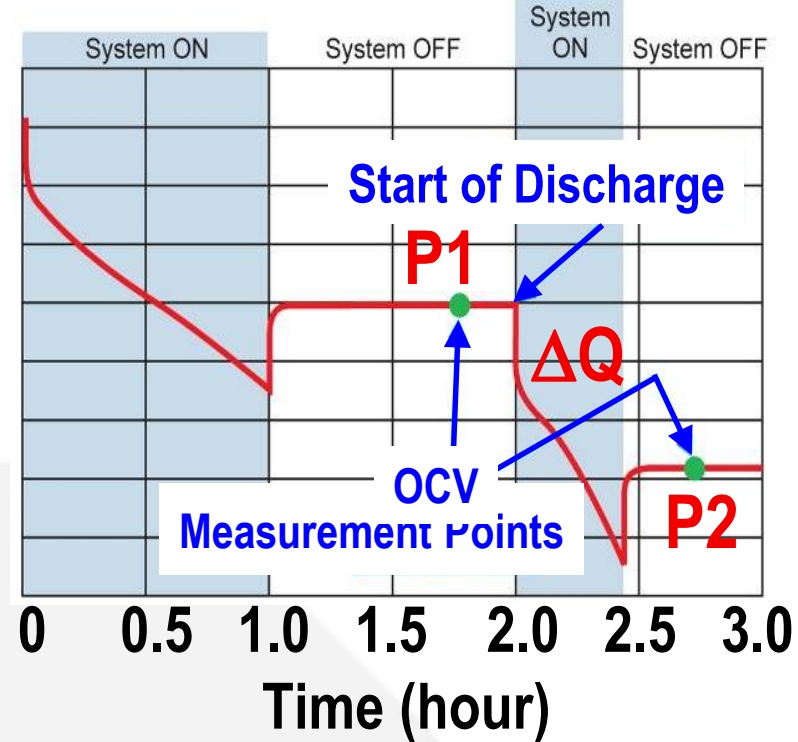
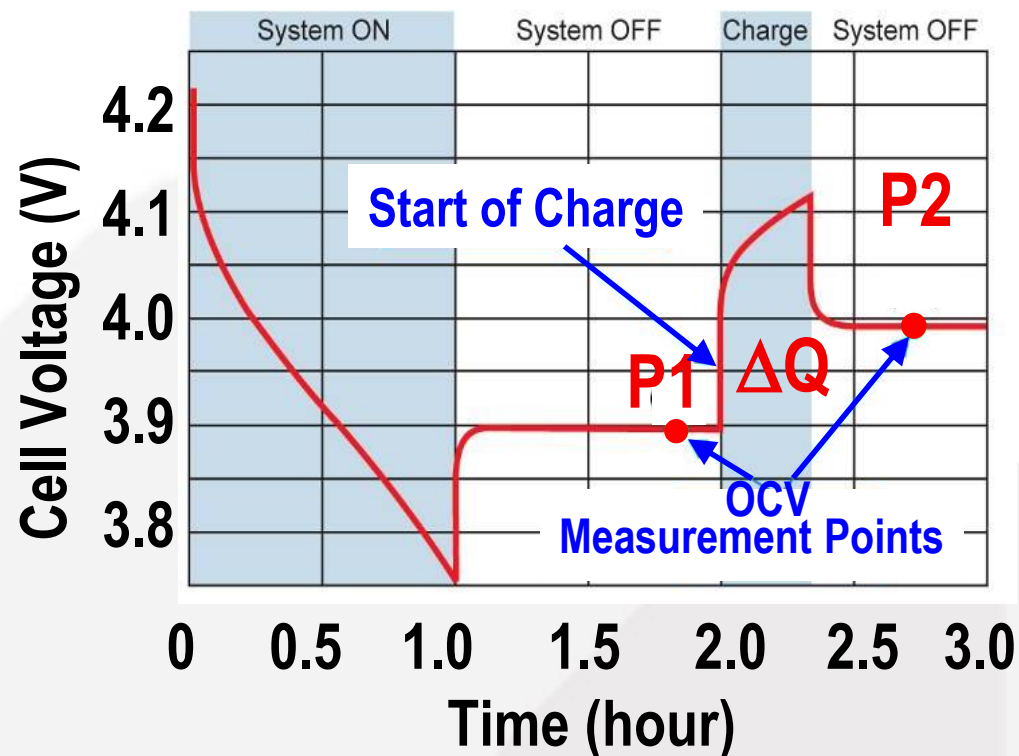

- Charge passed is determined by exact coulomb counting
- SOC1 and SOC2 measured by its OCV
- Method works for both charge or discharge exposure

$$Q_{max} = \frac{\Delta Q}{SOC1 - SOC2}$$

- Data flash contains a fixed table:  $OCV = f(SOC, T)$
- IT algorithm: Real-time measurements and calculations during charge and discharge.

$$R_{BAT} = \frac{OCV - V_{BAT}}{I_{AVG}}$$

$$V = OCV(T, SOC) - I * R(T, SOC, Aging)$$

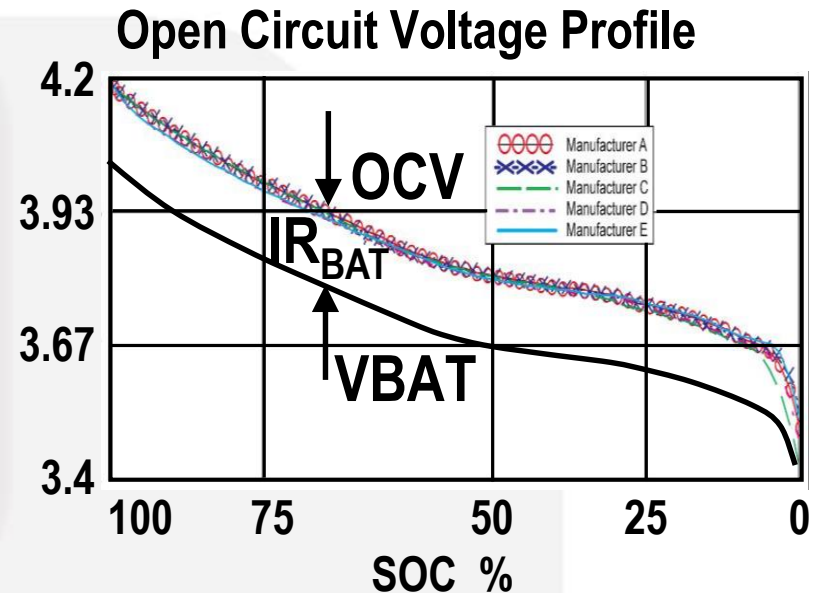

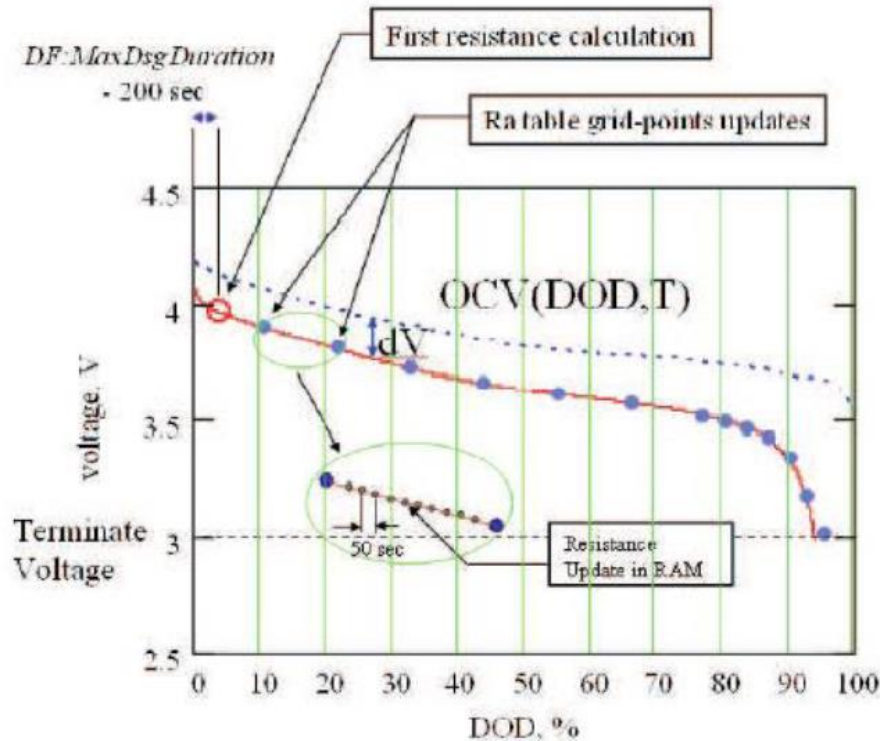

M	Grid Point
0	100
1	88.9
2	77.8
3	66.7
4	55.6
5	44.5
6	33.4
7	22.3
8	19
9	15.7
10	12.4
11	9.1
12	5.8
13	2.5
14	0

Figure 12. Impedance Updates

- After the waiting time, R is updated every 50s to RAM
- R is updated in the Data Flash (Ra table) at Grid Point

# Combination of integration and correlation

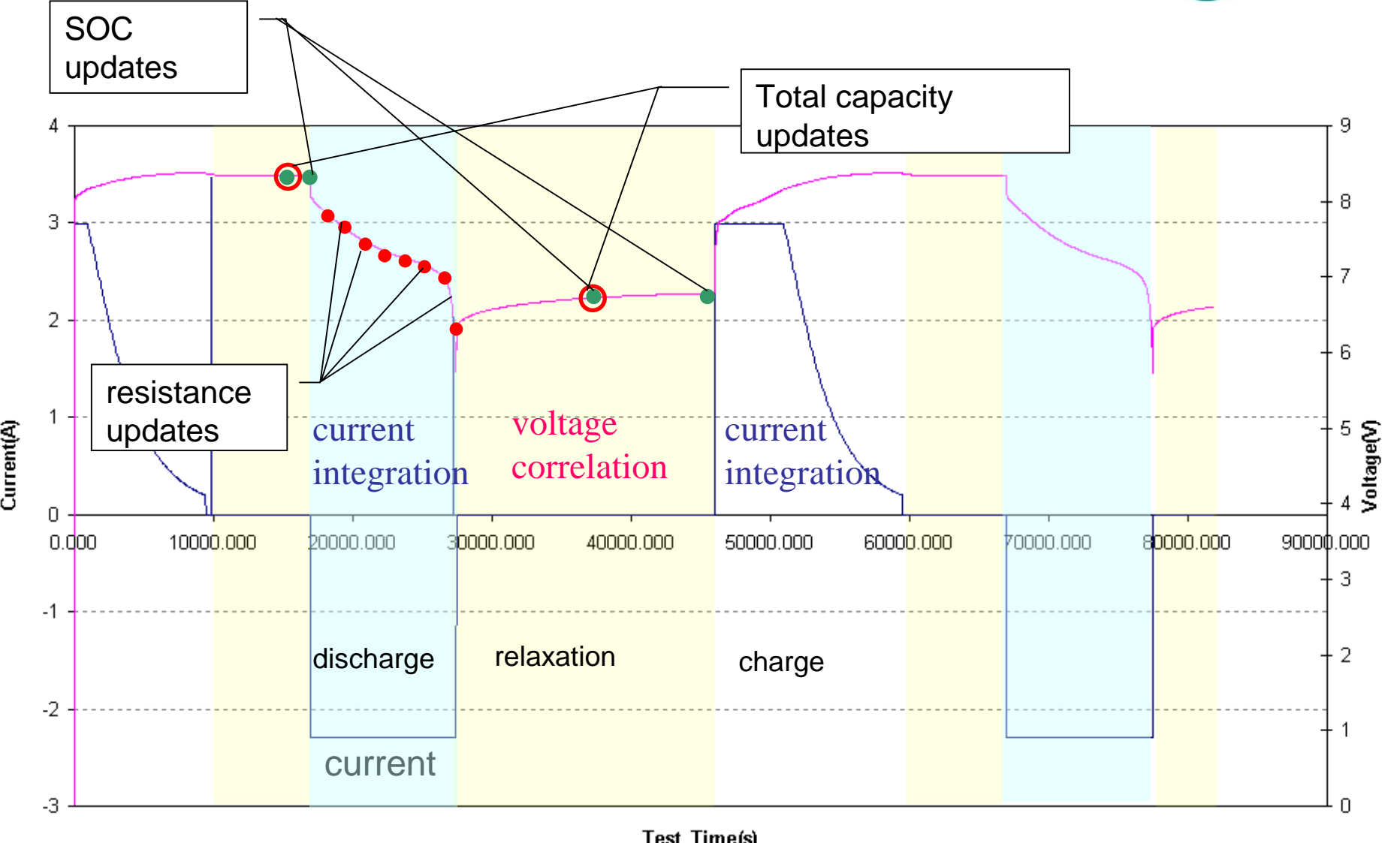

## 1. Chemistry table in Data Flash:

$$OCV = f(dod)$$

$$dod = g(OCV)$$

## 2. Impedance learning during discharge:

$$R = \frac{OCV - V}{I}$$

## 3. Update Max Chemical Capacity for each cell

$$Q_{max} = \text{PassedCharge} / (\text{SOC1} - \text{SOC2})$$

## 4. Run periodic simulations to update predictions of Remaining and Full Capacity



**SERIAL**  
新擘集團

# TI Single Cell Fuel Gauge Solution

Your Integral Component to Success

# Single-Cell Fuel Gauge Type

Pack-side

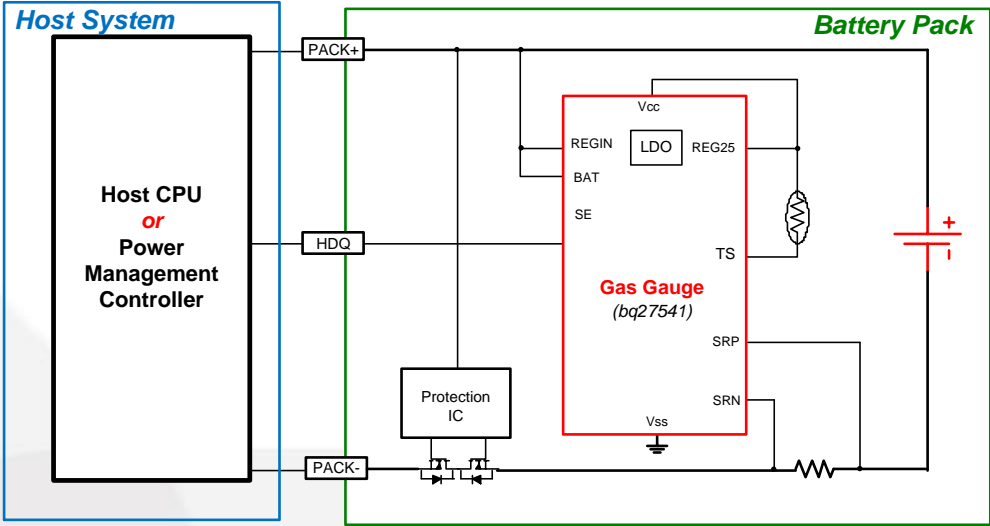

System-side

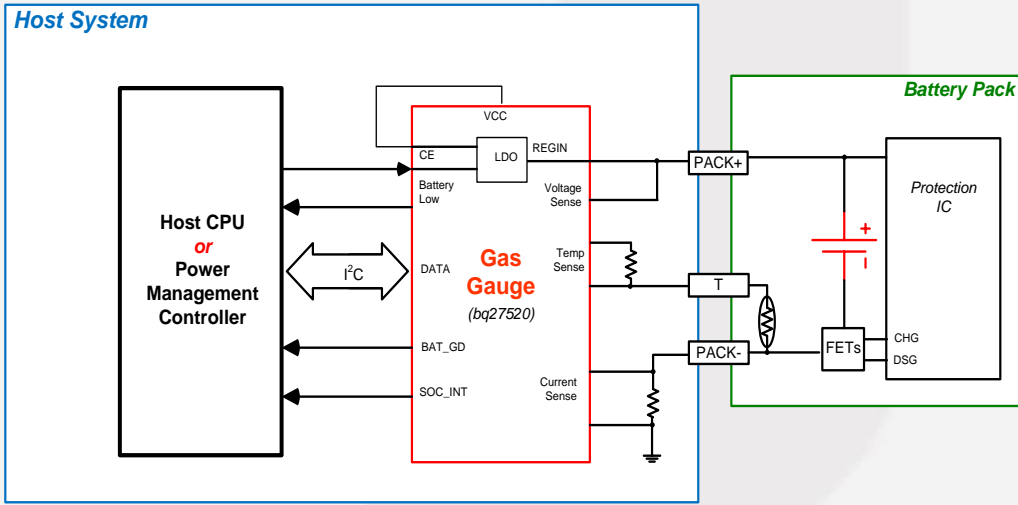

# Single-Cell Fuel Gauge Type

aka "pack-side"

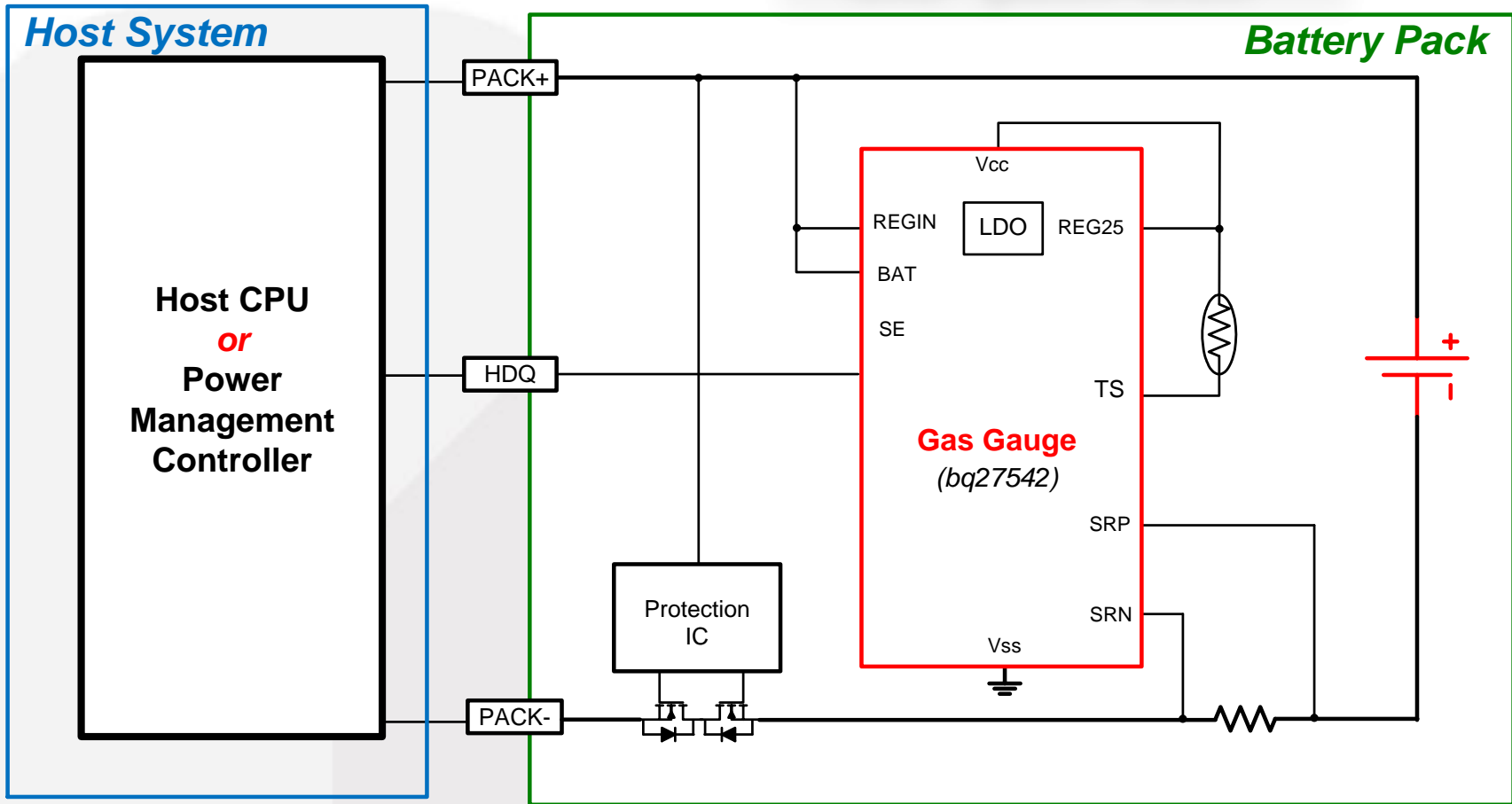

# Single-Cell Fuel Gauge Type

aka “system-side” / “host-side”

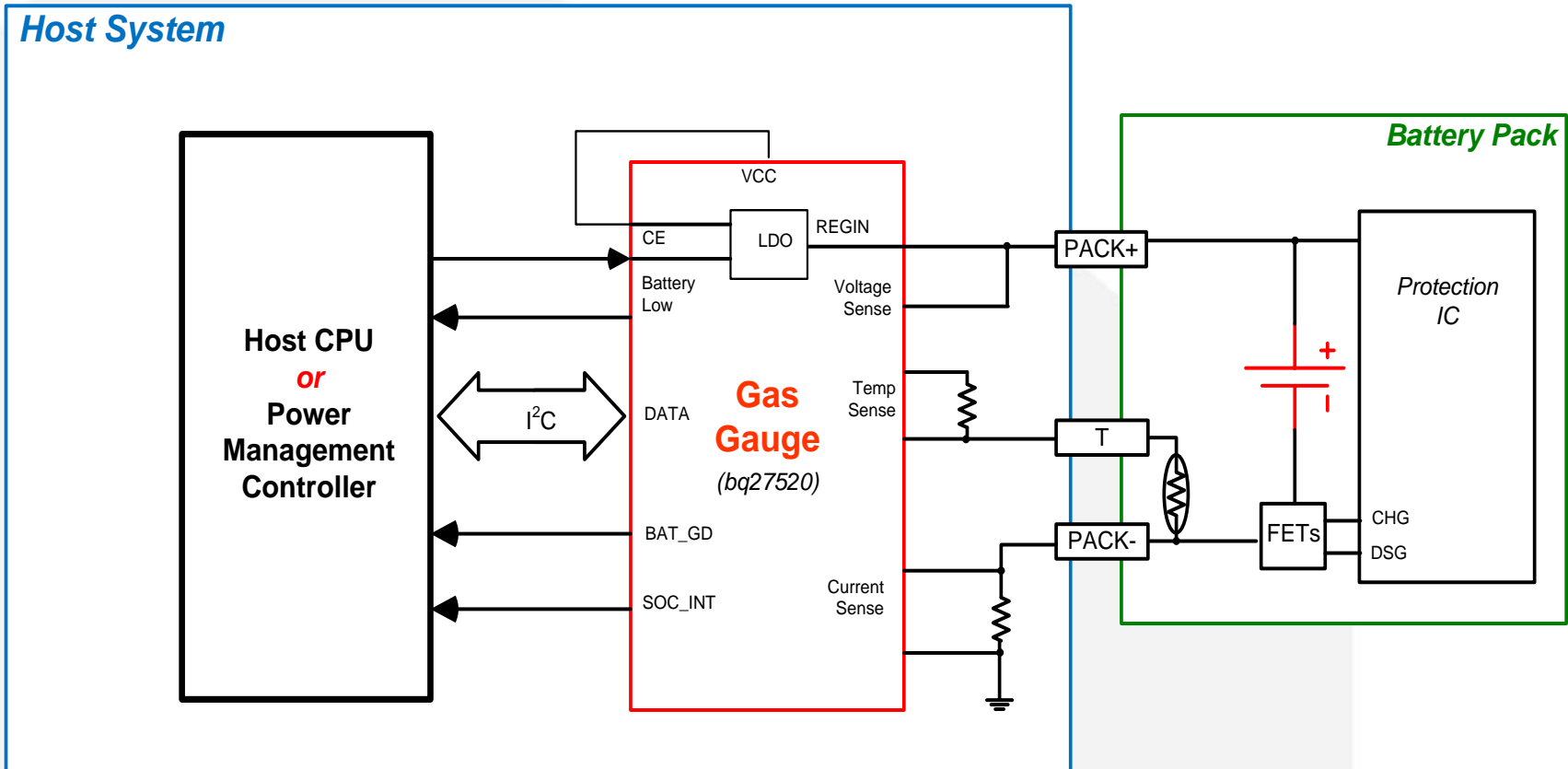

# Discrete Single Cell Gauge

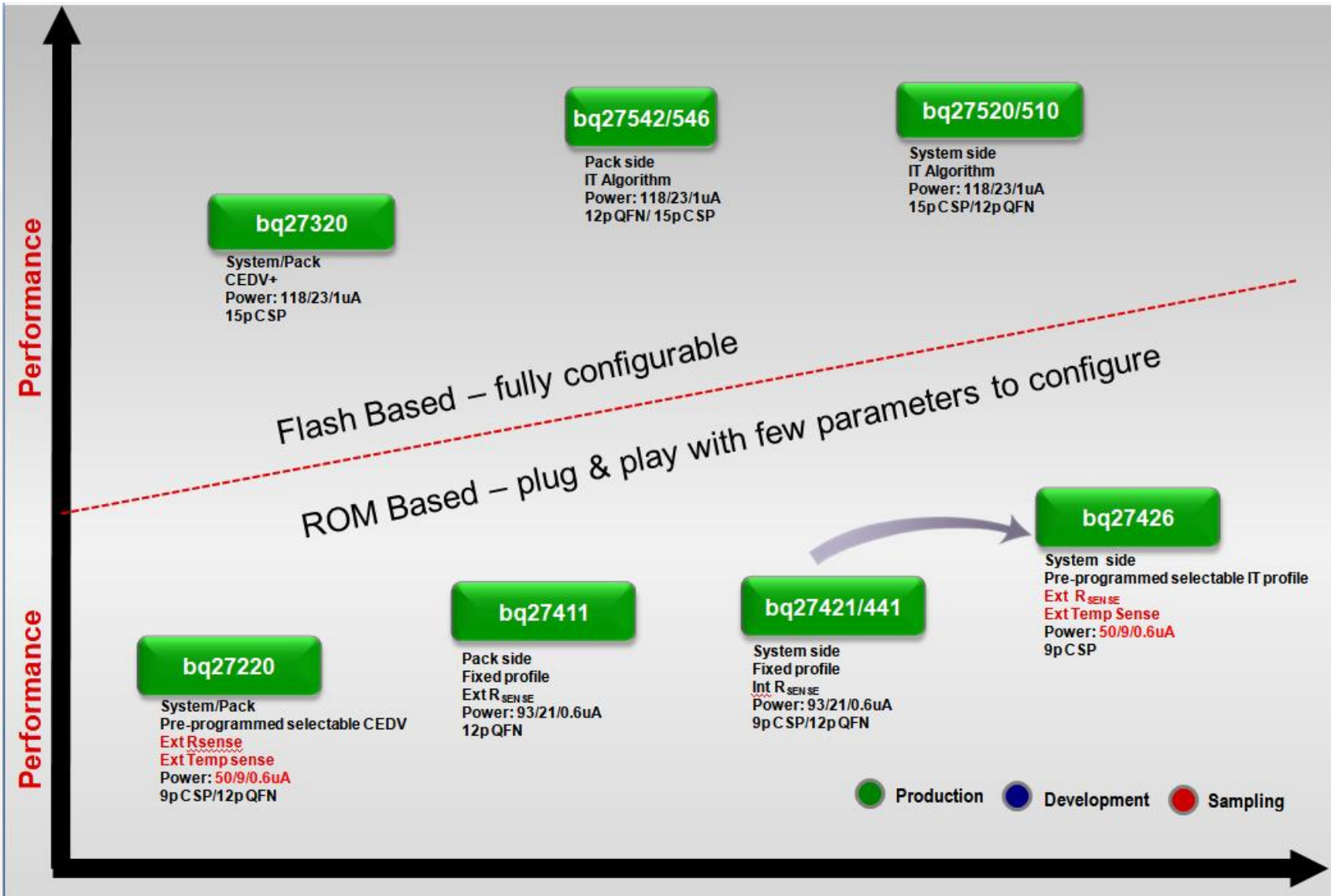

# Discrete Single Cell Gauge Selection Guide



	Algorithm	R <sub>SENSE</sub>	Package	Size	Architecture
bq27520	IT	External	CSP	2.6 x 2 mm	System Side
bq27320	CEDV+	External	CSP	2.6 x 2 mm	System/Pack
bq27426	IT-Lite, fixed profile	External	CSP	1.6 x 1.6 mm	System Side
bq27427	IT-Lite, fixed profile	External	QFN	2.6 x 4 mm	System Side
bq27421	IT-Lite, fixed profile	Integrated	CSP	1.6 x 1.6 mm	System Side
bq27441	IT-Lite, fixed profile	Integrated	QFN	2.6 x 4 mm	System Side
bq27220	CEDV+	External	CSP	1.6 x 1.6 mm	System/Pack
bq27221	CEDV+	External	QFN	2.6 x 4 mm	System/Pack
bq27411	IT-Lite, fixed profile	External	QFN	2.6 x 4 mm	Pack Side
bq27542	IT	External	SON	2.6 x 4 mm	Pack Side
bq27546	IT	External	CSP	2.6 x 2 mm	Pack Side

● Production  
 ● Development  
 ● Sampling

# CEDV vs Impedance Track

Property	CEDV	Impedance Track
Worst error new, learned	<b>+/-2%</b>	<b>+/-1%</b>
Worst error aged, learned	<b>+30% (+/- 15% with age data)</b>	<b>+/-2%</b>
Data collection	<b>3 temperatures, 2 rates, Fitting to obtain parameters. 1 week</b>	<b>Chemistry selection test, Optimization cycle 1 week</b>
Instruction flash	<b>small</b>	<b>large</b>
Voltage accuracy requirement	<b>20mV/pack</b>	<b>3mV/pack</b>
State of charge initialization (host side requirement)	<b>Yes</b>	<b>Yes</b>
FCC temperature compensation	<b>No</b>	<b>Yes</b>
FCC rate compensation	<b>No</b>	<b>Yes</b>
Learning cycle in production	<b>required</b>	<b>Not required</b>

## \* **ROM based gauges (bq274xx and bq27621)**

OTP store FW, default configuration parameters, chemID and Ra table.

Fast configuration

Accuracy error expected to be <5%

## \* **FLASH based gauges (bq275xx, bq277xx family and bq27320)**

Flash memory is available in large block sizes to accommodate entire software algorithms.

All firmware in FLASH and all configurable data parameters in FLASH (chemID and Ra table)

More time to get configuration

Accuracy error expected to be <1%

# Development Set up

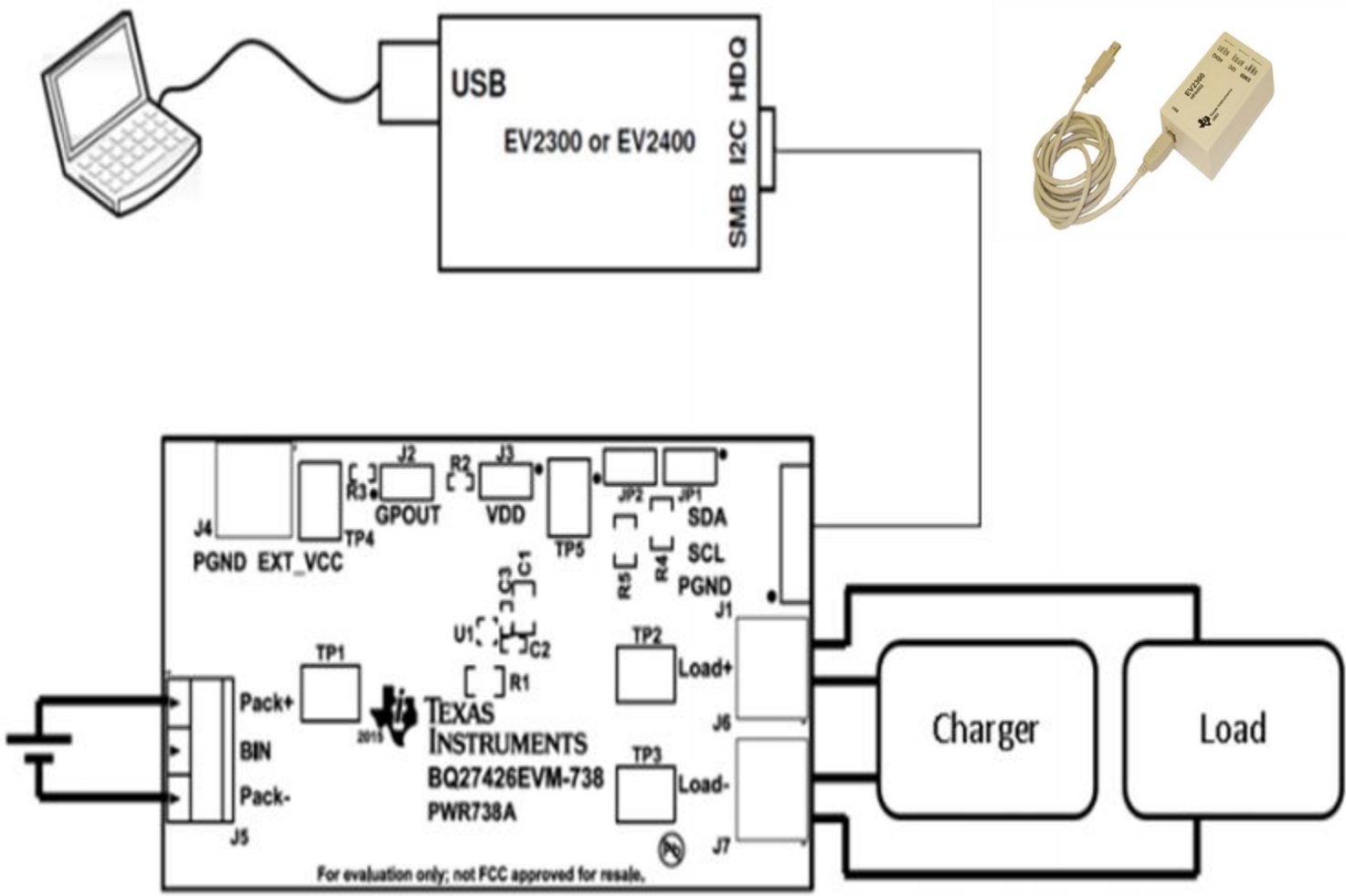

# Development Tool – BQ Studio



Battery Management Studio ( bqStudio ) 1.3.44

File View Window Help

Project Registers Data Memory Commands Calibration Authentication Chemistry Advanced Comm Programming Golden Image Watch Data Graph Errors Learning Cycle Parameter Q&A I2C To HDQ

Dashboard

**Auto Refresh is ON - Click to Turn OFF**

bqStudio Version: 1.3.44

EV2300  
Version:3.1r

I2C

bq27541G1  
0541\_2\_24  
Addr: 0xAA  
30.2 °C

4001 mV  
81%

### Registers

Start Log Scan Refresh

Name	Value	Units	Name	Value	Units	Name	Value	Units
<input checked="" type="checkbox"/> Control	0x0224	Hex	<input type="checkbox"/> Full Charge Capacity	945	mAh	<input type="checkbox"/> Filtered RM	760	mAh
<input checked="" type="checkbox"/> At Rate	0	mA	<input type="checkbox"/> Average Current	0	mA	<input type="checkbox"/> Average Power	0	mw/cw
<input type="checkbox"/> Unfiltered SOC	81	%	<input type="checkbox"/> Time to Empty	65535	Min	<input type="checkbox"/> Internal Temperature	25.3	°C
<input type="checkbox"/> Temperature	30.2	°C	<input type="checkbox"/> Filtered FCC	945	mAh	<input type="checkbox"/> Cycle Count	0	Num
<input type="checkbox"/> Voltage	4001	mV	<input type="checkbox"/> Standby Current	-10	mA	<input type="checkbox"/> State Of Charge	81	%
<input type="checkbox"/> Nom Available Capacity	778	mAh	<input type="checkbox"/> Unfiltered FCC	945	mAh	<input type="checkbox"/> State Of Health	95	Num
<input type="checkbox"/> Full Available Capacity	963	mAh	<input type="checkbox"/> Max Load Current	-500	mA	<input type="checkbox"/> Passed Charge	0	mAh
<input type="checkbox"/> Remaining Capacity	760	mAh	<input type="checkbox"/> Unfiltered RM	760	mAh	<input type="checkbox"/> DOD0	3504	Num
						<input type="checkbox"/> Self Discharge Current	0	mA
						<input type="checkbox"/> Design Capacity	1000	mAh

### Bit Registers

Name	Value	Bit7	Bit6	Bit5	Bit4	Bit3	Bit2	Bit1	Bit0
<input type="checkbox"/> Control Status (hi...)	0x0094	SE	FAS	SS	CALMODE	CCA	BCA	RSVD	HDQHOSTIN
<input type="checkbox"/> Control Status (lo...)		SHUTDWN	HIBERNATE	FULL SLEEP	SLEEP	LDMD	RUP_DIS	VOK	QEN
<input type="checkbox"/> Flags (high)	0x0108	OTC	OTD	BATHI	BATLOW	CHG_INH	RSVD	FC	CHG
<input type="checkbox"/> Flags (low)		OCVTAKEN	ISD	TDD	HW1	HW0	SOC1	SOFC	DSG
<input type="checkbox"/> Pack Configuratio...	0x5177	RESCAP	CALEN	INTPOL	INTSEL	RSVD	WAKE	RSNS1	RSNS0
<input type="checkbox"/> Pack Configuratio...		GNDSEL	RFACTSTEP	SLEEP	RMFCC	SE_PU	SE_POL	SE_EN	TEMPS

Bit Status 0
  Bit Status 1

### Commands

CONTROL\_STATUS

DEVICE\_TYPE

FW\_VERSION

HW\_VERSION

RESET\_DATA

PREV\_MACWRITE

CHEM\_ID

BOARD\_OFFSET

CC\_OFFSET

CC\_OFFSET\_SAVE

DF\_VERSION

Manual Control Panel

Enter Cmd Delay Ms

1000

Read Addr Length

Log Panel Clear Log

Transaction Log

Name	Cmd	Result



- Characterize battery
- Determine CEDV constants
- Test gauge and optimize
- Finalize golden file
- Ready for production
  - Program and test PCB

## Created from **seven text files**

- Discharge log at high temperature & high average current
- Discharge log at room temperature & high average current
- Discharge log at low temperature & high average current
- 3 more, as above for low average current
- Simple config file
  - Number of cells in series
  - Termination voltage
  - Miscellaneous
- Web-based tool – Just remember:
  - TI.com
  - Search for “Gauging” or “GPC”
  - Choose link to Gauging Parameter Calculator

- Determine chemID (battery profile)
- Perform learning cycle
- Test gauge and optimize
- Finalize golden file
- Ready for production
  - Program and test PCB

## 1-2-3 Battery Characterization for Impedance Track Chemistry ID

1. Lookup the cell/pack in the TI database to see if there is an existing chemID.
2. If not found, create discharge logs and test for match to existing chemID with TI tool.
3. If no match, send cells to TI to characterize and create a new chemID .

# Learning Cycle

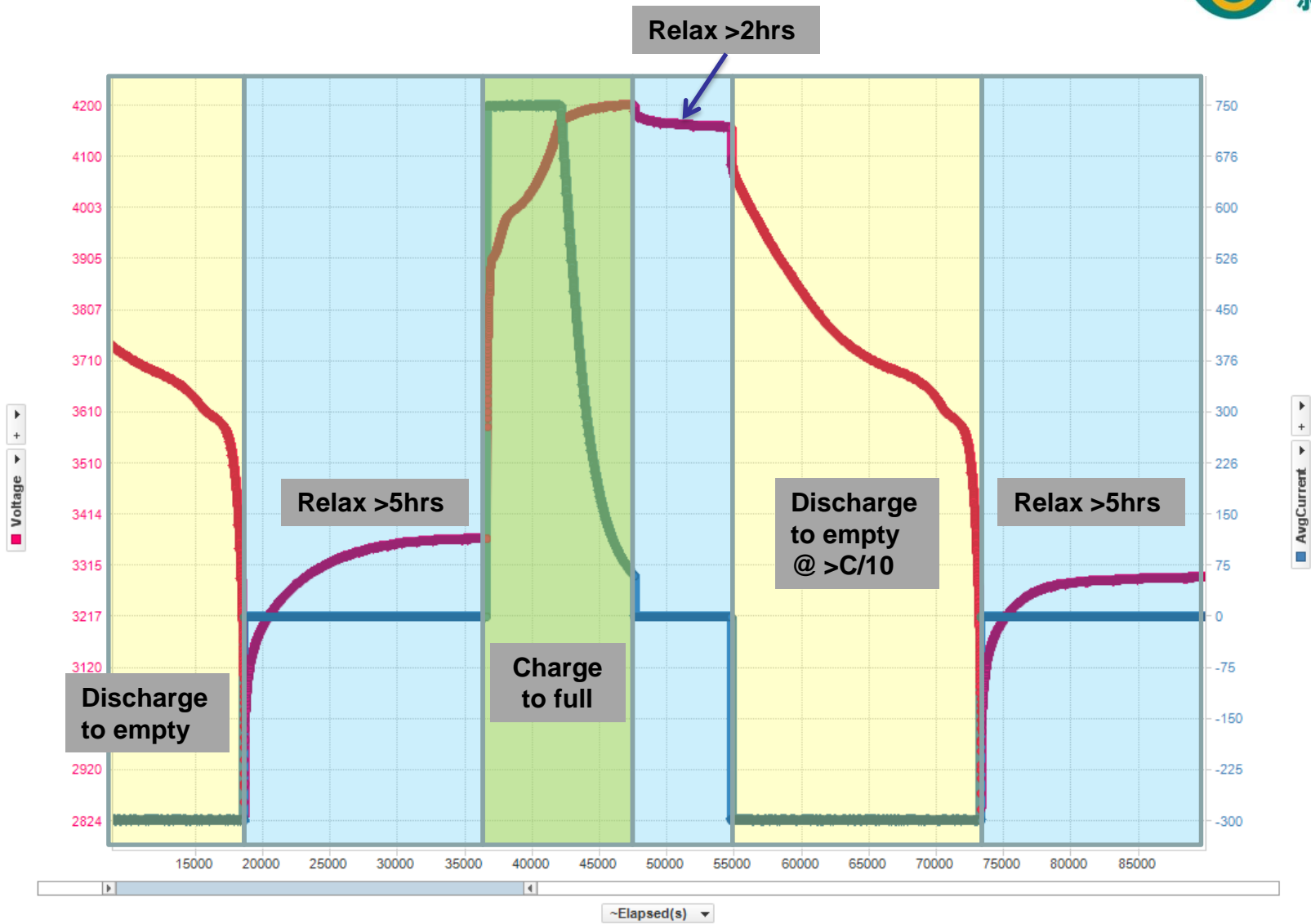



**SERIAL**  
新曄集團

**Thank you**

**SS Jung**  
**ss.jung@serialsystem.com**

**2018 2Q**

Your Integral Component to Success