

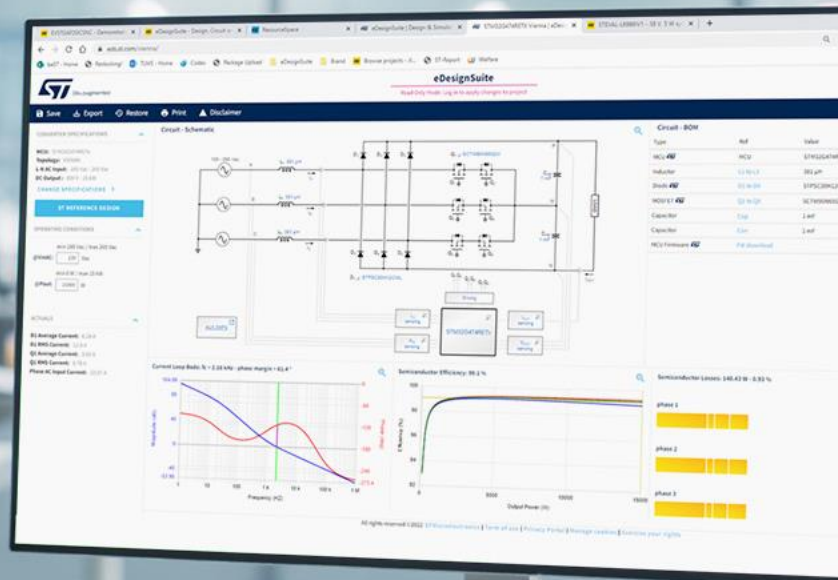

life.augmented



eDesignSuite와 eDSim을 활용한 DC-DC 컨버터 설계: Leading the innovation of Design tools

STMicroelectronics

권경희 대리

Agenda

1 Introduction to eDesignSuite

4 Digital Power Workbench

2 Power management design center

5 Takeaway

3 New features:

- eDSim
- Evaluation board advisor
- Export to CAD
- Power tree designer



System SW tools to support engineers in their system design effort through a compelling, coherent and engaging user experience

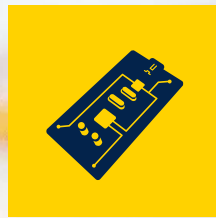

More **accurate**, more **reliable** and more **intuitive** design process



Improved **user experience** with multi-language console



Clever user interactions: reworked engine, optimized algorithms, improved portability



Power management design center

Power supply design tool

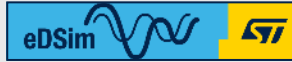

NEW



Export to CAD

NEW

Evaluation boards

NEW

LED lighting design tool



Export to CAD

NEW

Evaluation boards

NEW

Digital power workbench



NEW

Thermal-electrical simulators for components



AC switches simulator



Rectifier diodes simulator



TVS simulator **NEW**



STPOWER Studio **NEW**

Signal conditioning design tools



Active filters

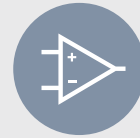

Comparators



Current sensing

NFC/RFID calculators



NFC inductance



UHF link budget **NEW**



NFC tuning circuit **NEW**



Where to find eDesignSuite?

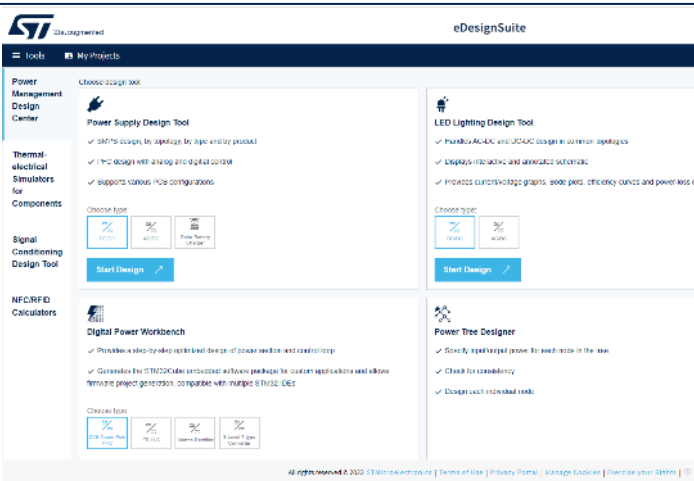

Load the eDesignSuite console
<https://eds.st.com/>

Find it under the “Tools & Software” widget
<https://st.com/>

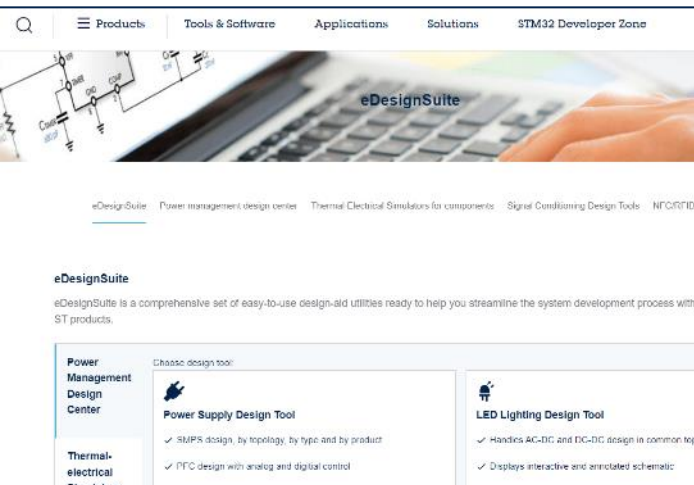
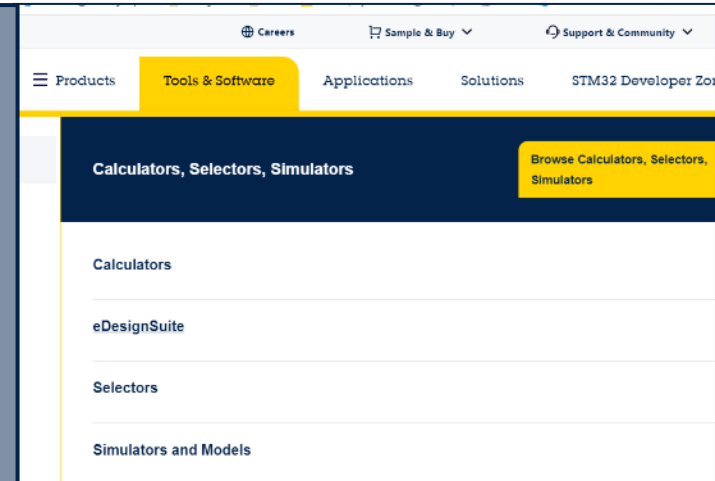

Visit the eDesignSuite page
<https://st.com/edesignsuite>

Launch it from any device product page

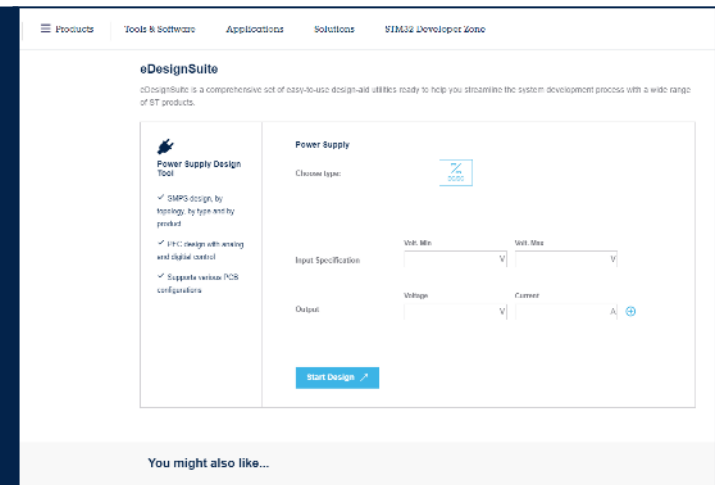

MOOC series in Appinium platform

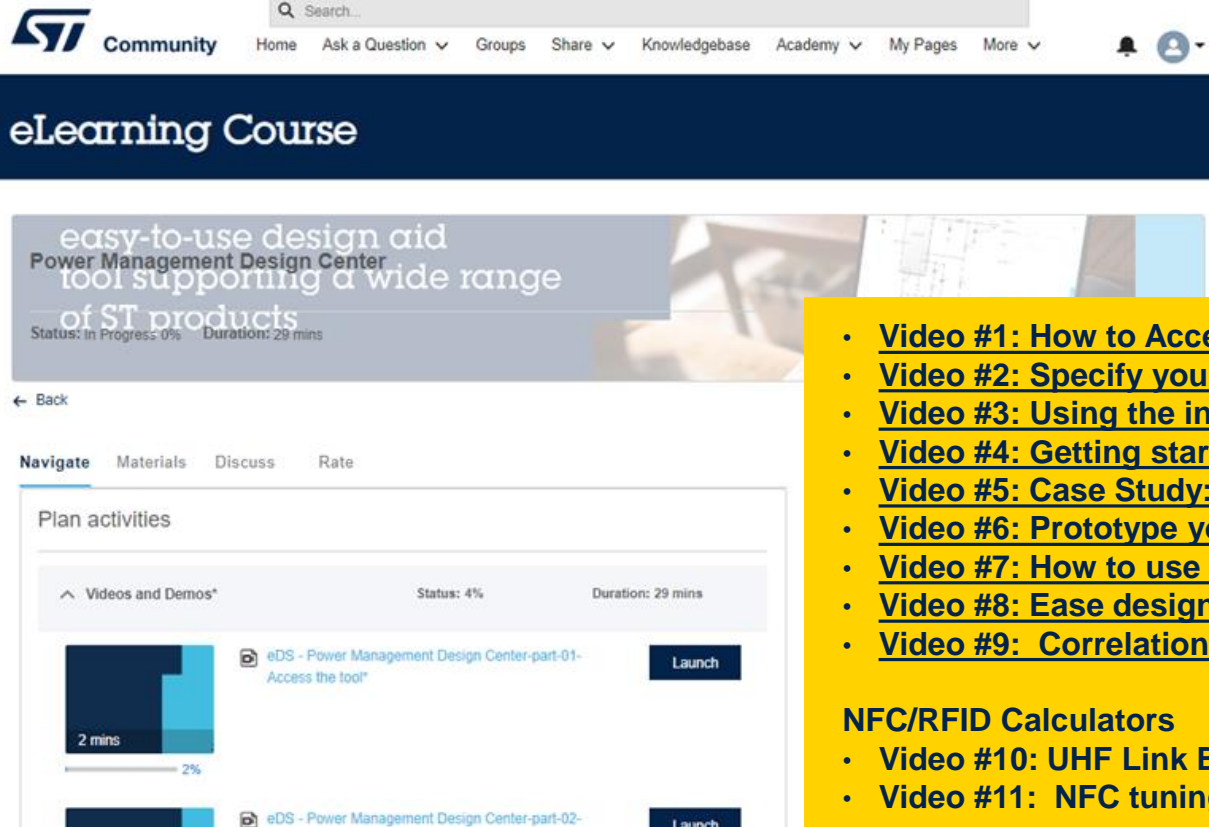

The screenshot shows the Appinium eLearning course interface. At the top, there is a navigation bar with the ST Community logo and a search bar. Below the navigation bar, the course title "eLearning Course" is displayed. The main content area features a banner for the "Power Management Design Center" with the text "easy-to-use design aid tool supporting a wide range of ST products". Below the banner, there is a "Plan activities" section with a table of video activities. The first activity is "eDS - Power Management Design Center-part-01- Access the tool" with a duration of 2 mins and a status of 2%. The second activity is "eDS - Power Management Design Center-part-02-" with a duration of 29 mins and a status of 4%. The overall course status is 4% and the total duration is 29 mins.

easy-to-use design aid
Power Management Design Center
tool supporting a wide range
of ST products
Status: In Progress: 0% Duration: 29 mins

← Back

Navigate Materials Discuss Rate

Plan activities

Activity	Status	Duration
eDS - Power Management Design Center-part-01- Access the tool*	2%	2 mins
eDS - Power Management Design Center-part-02-	4%	29 mins

- [Video #1: How to Access the tool](#)
- [Video #2: Specify your use case and Select a matching IC](#)
- [Video #3: Using the interactive dashboard to Analyze and Refine your design's operating conditions](#)
- [Video #4: Getting started with eDSim for accurate Simulation of your circuit design](#)
- [Video #5: Case Study: Design and Simulate L6983 buck converter operation with eDSim](#)
- [Video #6: Prototype your circuit desing](#)
- [Video #7: How to use the evaluation board selector](#)
- [Video #8: Ease design of digitally controlled converters with Digital Power Workbench](#)
- [Video #9: Correlation of eDesignSuite/eDSim simulations vs. bench measurements](#)

NFC/RFID Calculators

- [Video #10: UHF Link Budget](#)
- [Video #11: NFC tuning circuit](#)

Power management design center



eDesignSuite PMDC: future enrichment

Get fast, accurate and reliable designs



Board advisor

- Helps select the evaluation board that best suits your needs



Power tree

- Multi-rail DC supply
- Switching converter or LDO stage



Export to CAD

- Export in real time eDesignSuite Schematics into OrCAD Capture format

Simplify board design

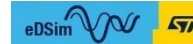

eDSim

- 10 to 50 times faster than SPICE when simulating SMPS
- Time and Frequency Domain simulations
- Provide Loop stability with Bode Plots

Detailed Time and frequency simulations



STPOWER Studio

- Dynamic electro-thermal simulation software dedicated to STPOWER devices

Power density Better system power simulation



Digital Power

- Power stage optimizer
- Digital feedback network designer
- STM32 FW generator

System design tool Analog + FW





Streamline your design process

1 Specify the application use-case

	Non Isolated	Buck, Multi-Output Buck, Boost, Buck-Boost
	Isolated	Buck, LLC
	Non Isolated	Buck, FF-Flyback, PFC Pre-Regulation
	Isolated	FF-Flyback, QR-Flyback, PWM Controllers

3 Analyze time & frequency domain results, efficiency and losses

5 Simulate the circuit with the fast and powerful eDSim tool

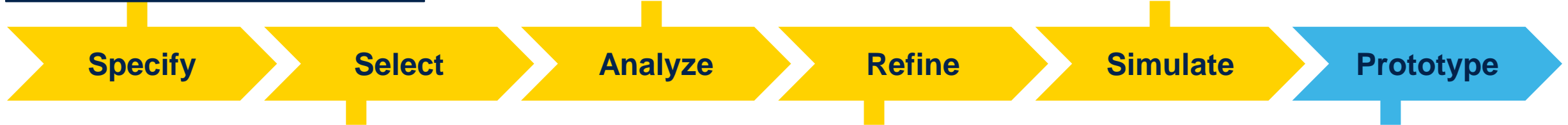

2 Select among the suggested ICs, the ones with specific features

4 Refine the specifications of the project

6 Export the OrCAD file to start the prototyping phase

eDesign Suite – how to find

- Go to st.com/edesignsuite
- or
- From **st.com** go to
 - Tools & Software -> Calculators, Simulators, Selectors -> eDesign Suite

The screenshot displays the STMicroelectronics website interface. The navigation menu at the top includes 'Tools & Software', which is highlighted in yellow. Below it, the sub-menu 'Calculators, Selectors, Simulators' is also highlighted in yellow. A pink arrow points from this sub-menu to the 'eDesignSuite' link. The main content area shows the 'eDesignSuite' page with a grid of design tools. A pink arrow points from the 'eDesignSuite' link to the 'Start Design' button of the 'Power Supply Design Tool'.

Select Product



eDesignSuite

English

Tools My Projects

Help

Power Supply Design Tools > DC/DC

1 Results

Specifications  [Reset All](#)

Vin min is required; Vin max is required; Vout is required; Iout is required

Input (Voltage)
Vin min is required Vin max is required

Output
Vout is required Iout is required

ADD OUTPUT

Output Power -

Features [Sorting](#)

Search L6983C50QTR

L6983C50QTR
Buck

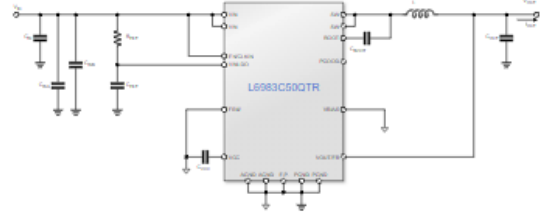

Vin: 5 - 38 V
Vout: 5 V
Iout: \approx 3 A
fosc: 400 kHz (200 - 2300 kHz)
fsync: none

 QFN16

[Datasheet](#) [Product Folder](#)

START DESIGN

54 MATCHING BOARD/S



Set Condition

- Input 20V-30V & Output 5V/1A → Start Design

The image shows a circuit schematic for an L6983C50QTR Buck converter. The schematic includes an input terminal V_{IN} connected to the VIN pin of the IC. Input capacitors C_{IN} , C_{INA} , and C_{INB} are connected to ground. A resistor R_{FILT} and capacitor C_{FILT} are connected between the VIN and VINLDO pins. The EN/CLKIN pin is connected to the VINLDO pin. The SW pin is connected to an inductor L , which is then connected to the output terminal V_{OUT} . A bootstrap capacitor C_{BOOT} is connected between the SW and BOOT pins. The PGOOD pin is connected to the output. The VBIAS pin is connected to ground. The VOUT/FB pin is connected to the output. The VCC pin is connected to ground through capacitor C_{VCC} . The FSW pin is connected to ground. The AGND, E.P., and PGND pins are connected to ground.

Specifications		Reset All
Input (Voltage)	Min V	Max V
	20	30
Output	Voltage	Current
	5	1
Output Power	5 W	

START DESIGN ▼

8 MATCHING BOARD/S
2 ADDITIONAL BOARD/S

All circuit parameters at a glance

Full set of commands

Fully annotated & interactive schematic

Project specifications

DC/DC CONVERTER SPECIFICATIONS

IC: L6983C50QTR
 Topology: BUCK
 Input: 20 - 30 V
 Output: 5 V (2% ripple) - 1 A max

Operating conditions

OPERATING CONDITIONS

from 20 to 30 V
 @Vin: 30 V
 from 1 mA to 1 A
 @Iout: 1 A
 from -40 to 150 °C
 @Ta: 25 °C

Fully annotated and interactive BOM

Type	Ref	Value	Description
IC	47	IC	L6983C50QTR
Capacitor	Cin	10 µF	50 V - 10% - muRata - GRM550...
Capacitor	Cout	120 µF	16 V - 20% - Würth Elektronik - ...
Inductor	L	39 µH	2.74 A - Würth Elektronik - 744...
Capacitor	Cvcc	1 µF	1 µF
Resistor	Rfilt	100 Ω	100 Ω
Capacitor	Cfilt	1 µF	1 µF
Capacitor	Cboot	100 nF	100 nF
Capacitor	CinA	1 µF	1 µF
Capacitor	CinB	1 µF	1 µF

Full set of analysis diagrams

Simulation: duty cycle 17.2%

Efficiency: 92.2%

Bode: fc = 32.29 kHz - phase margin = 107.4°

Losses: 422 mW - 7.79%

- IC: 364 mW - 86.27%
- Inductor: 57 mW - 13.58%
- Other: 1 mW - 0.15%



Full set of analysis diagrams

Interactive dashboard for refinement and custom components

Circuit - Schematic

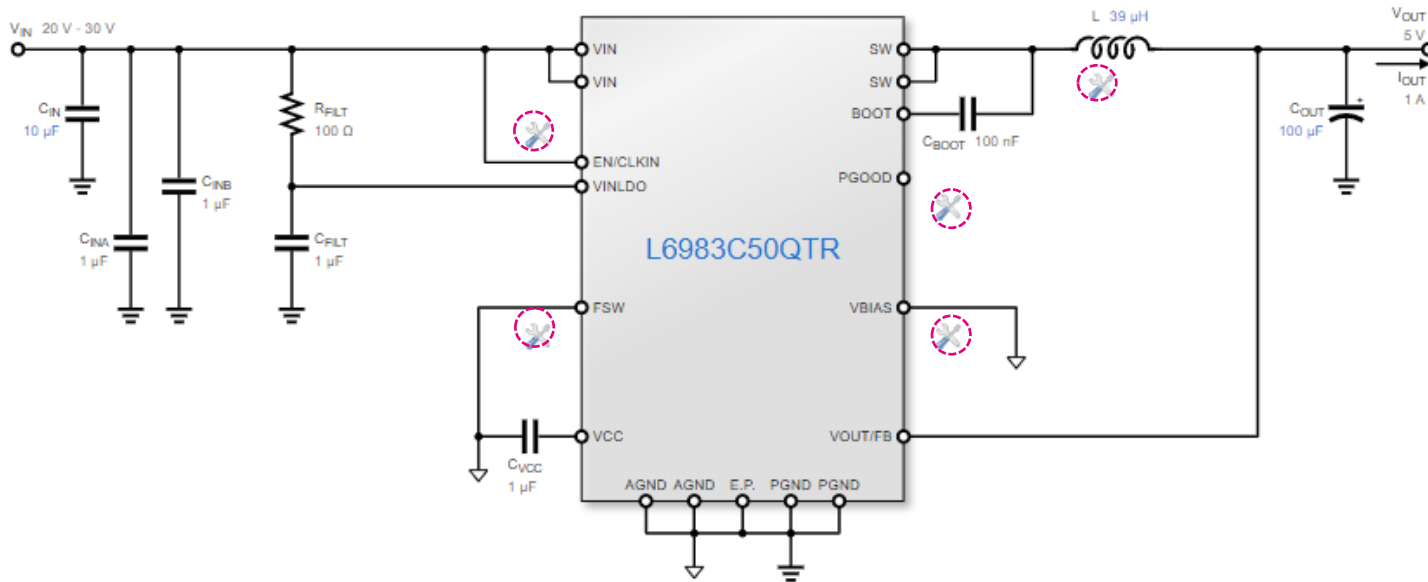

Circuit - BOM



Type	Ref	Value	Description
IC	IC	L6983C50QTR	L6983C50QTR - ...
Capacitor	Cin	10 µF	50 V - 10% - mu...
Capacitor	Cout	100 µF	6.3 V - 20% - Sa...
Inductor	L	39 µH	2.74 A - Würth E...
Capacitor	Cvcc	1 µF	
Resistor	Rfilt	100 Ω	
Capacitor	Cfilt	1 µF	
Capacitor	Cboot	100 nF	
Capacitor	CinA	1 µF	
Capacitor	CinB	1 µF	



INTERACTIVE DASHBOARD

The user can refine sections of the circuit (clamer net, passive components, compensation net, MOSFETs, diodes, etc)

INDUCTOR
You can select inductor with real spec.

L6983C50QTR BUCK Design Wizard

IO SPECIFICATION

ADDITIONAL REQUIREMENTS

INDUCTOR SELECTION

INPUT CAPACITOR

OUTPUT CAPACITOR

INDUCTOR SELECTION

AUTOSELECTED REPLACE

Part Number: 744771139

Manufacturer: Würth Elektronik

Value: 39 µH

DCR: 57 mΩ

Irms: 2.49 A

Isat: 2.74 A

Mount Type: Surface Mount



Your design gets portable and exportable

Save



Save your project on ST server. Open it from any machine. Your design gets portable!

Export



Export the schematic and Bill of Material



Save **Export** **Export dsn OrCAD** **Export for eDSim** **Restore** **Print** **Disclaimer**

NEW

Save **Export** **Export dsn OrCAD** **Export for eDSim** **Restore** **Print** **Disclaimer**

DC/DC CONVERTER SPECIFICATIONS

IC: L6983C50QTR
 Topology: BUCK
 Input: 6.5 - 19V
 Output: 5V (2% ripple) - 3A max
 CHANGE SPECIFICATIONS >

2 MATCHING BOARD/S

CONVERTER OPTIMIZATION

reduced BOM Neutral Maximum efficiency

OPERATING CONDITIONS

min 6.5V / max 19V
 @Vin: 19V
 min 1mA / max 3A
 @Iout: 3A
 min -40°C / max 150°C
 @Tc: 25°C

ACTUALS

Vout: 5V
 ripple: 42mV - 0.85%
 IL ripple: 824mA - 27.46% of 3A
 fsw: 400kHz
 Tmc: 706.03ns

https://eds.st.com/console/#/support/en/home_st

Circuit - Schematic

Circuit - BOM

Type	Ref	Value
IC	IC457	L6983C50QTR
Capacitor	Cin	10µF
Capacitor	Cout	100µF
Inductor	L	12µH
Capacitor	Cvcc	1µF
Resistor	Rfilt	100Ω
Capacitor	Cfilt	1µF
Capacitor	Cboot	100nF
Capacitor	CinA	1µF
Capacitor	CinB	1µF

Simulation: duty cycle 28.2%

Efficiency: 90.7%

Bode: fc = 18.2 kHz - phase margin = 70.3°

Losses: 1.54 W - 9.29%

IC Inductor Other

All rights reserved ©2022 STMicroelectronics | Term of use | Privacy Portal | Manage cookies | Exercise your rights

NEW

Save **Export** **Export dsn OrCAD** **Export for eDSim**



Export

an OrCAD file of your project to start the prototyping phase



Export and customize

the eDesignSuite project on eDSim

New features

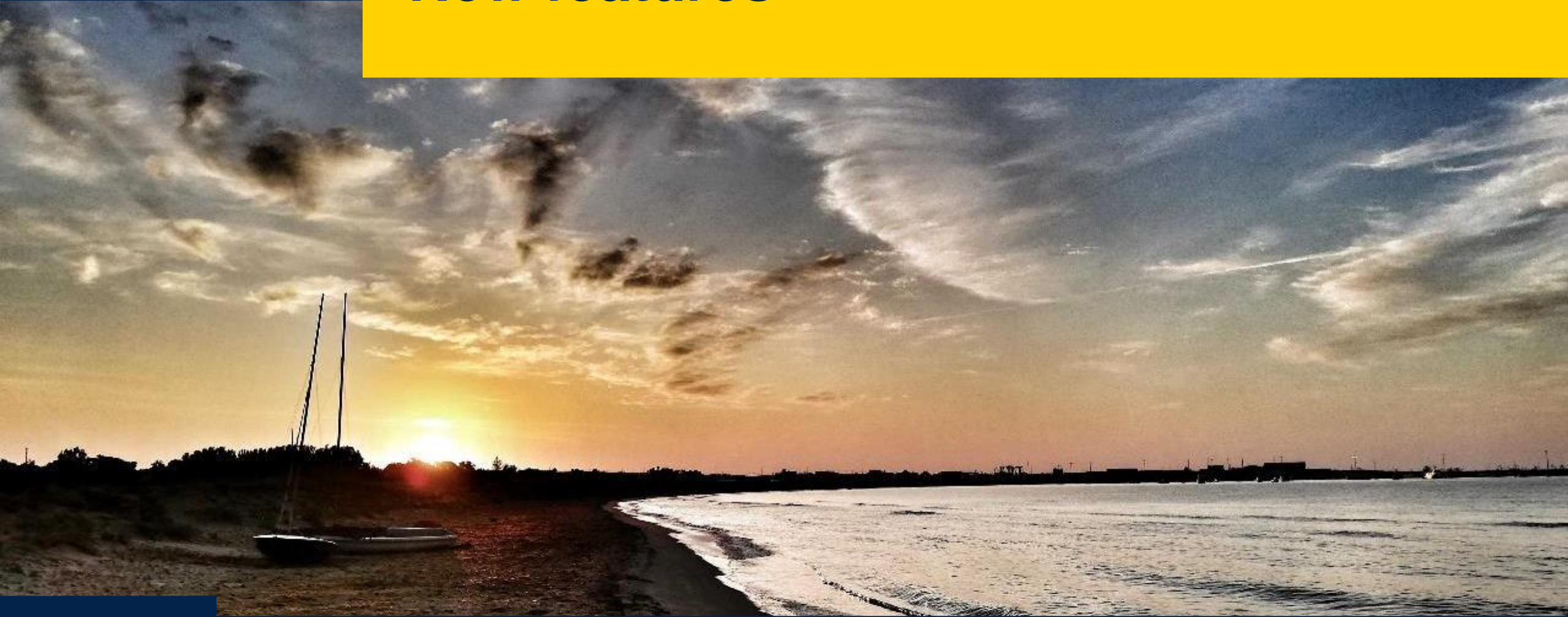

A complete powerful tool to reduce risks in hardware prototyping



- Fine tune your IC behavior and related best configuration
- Extend the analysis in Time/frequency domain.
- Dive in specific usage case condition (mission profile)

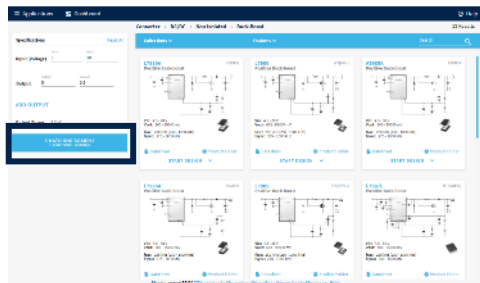

- Helps select the evaluation board that best suits your needs

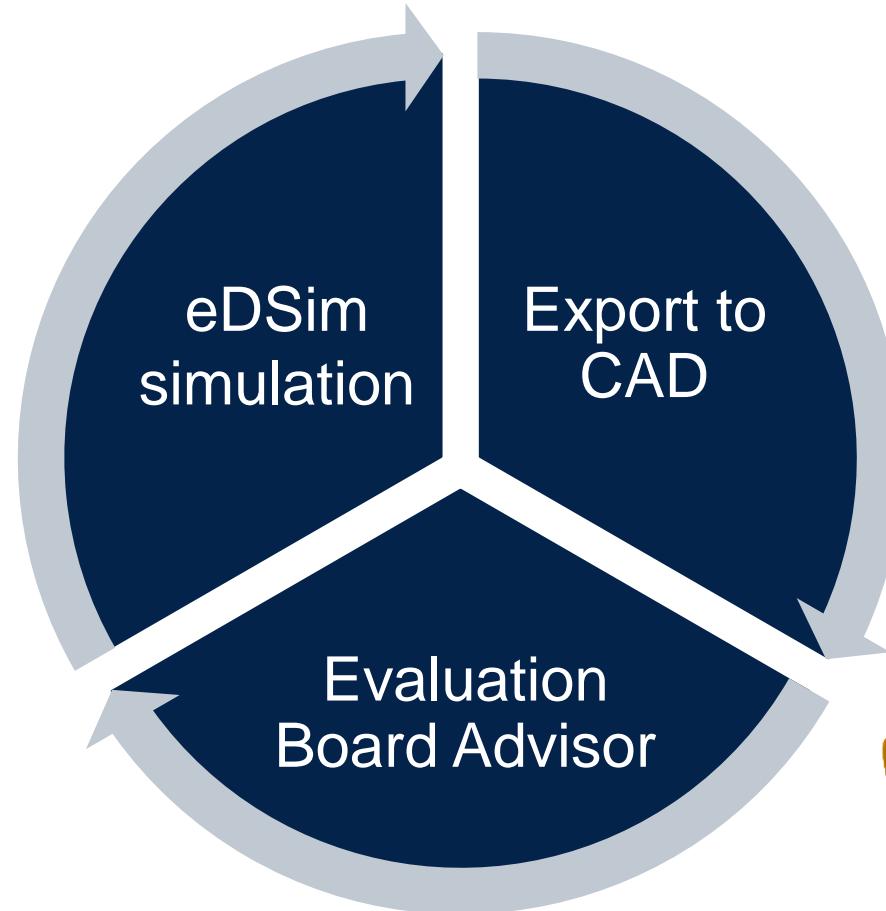

- Define your best system solution proposal
- Export in real time eDesignSuite Schematics into OrCAD Capture format

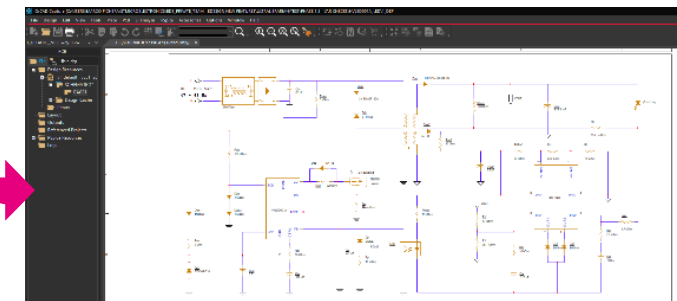
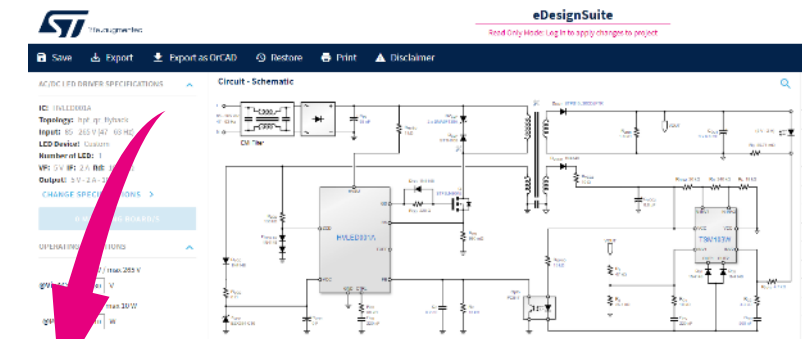

eDSim



New fast and powerful simulator for SMPS and analog ICs

Crunch your electrical simulation 10-50 times faster than traditional analog SPICE simulators

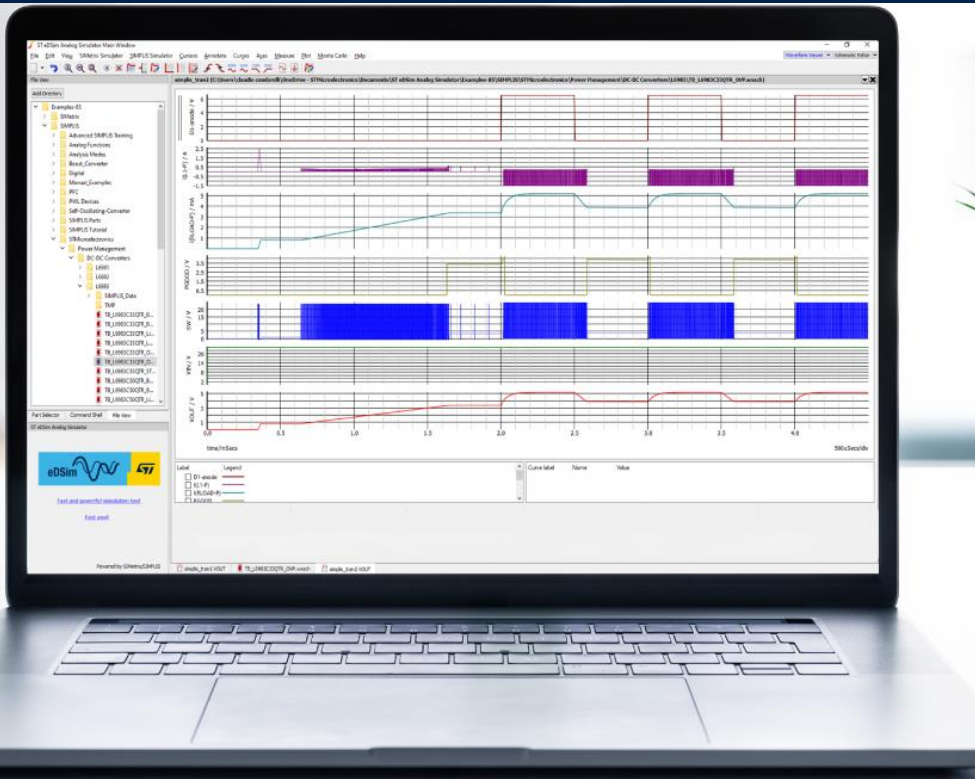

- 10 to 50 times faster than SPICE when simulating SMPS
- Time and Frequency Domain simulations
- Provide Loop stability with Bode Plots
- Based on SIMPLIS engine, in line with main competitors (i.e. Maxim, Renesas, MPS)



Start simulation with eDSim



How to use eDSim?

- Buck Converter example





Parameter	Value
Vin	12V
Vout	1.2V
Iout	10A
Fsw	500KHz

- SIMPLIS Schematic을 사용하여 open loop 회로도 생성
- SIMPLIS의 3가지 분석방법을 통해 시뮬레이션 진행



2. Download

3. Run

Name	Status	Date modified	Type	Size
 eDSim.bat	✓	7/25/2022 4:54 AM	Windows Batch File	1 KB
 L6983C50QTR_startup_L6983.compvalues...	✓	7/25/2022 4:54 AM	Text Document	1 KB
 L6983C50QTR_startup_L6983.wxsch	✓	7/25/2022 4:54 AM	Schematic	543 KB
 readme.txt	✓	7/25/2022 4:54 AM	Text Document	1 KB



Simulation examples

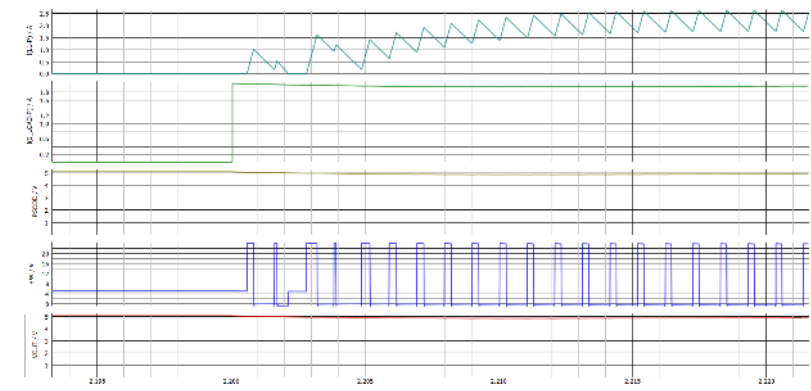
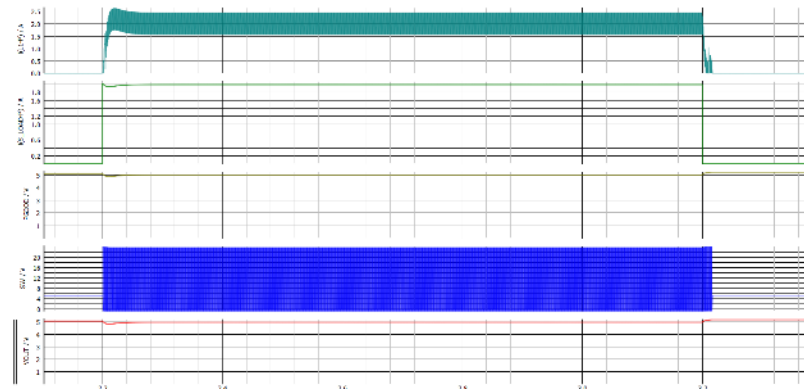
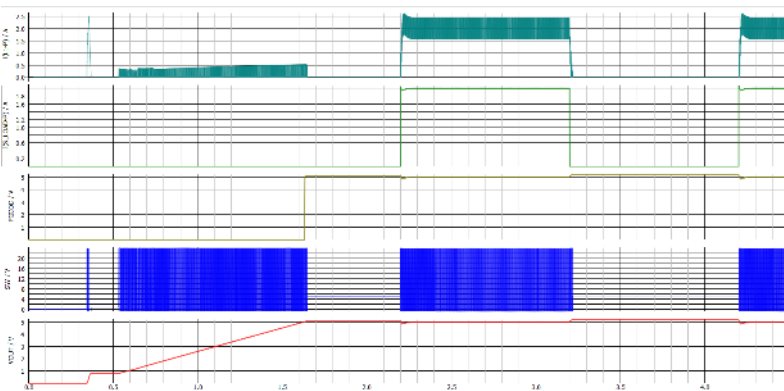
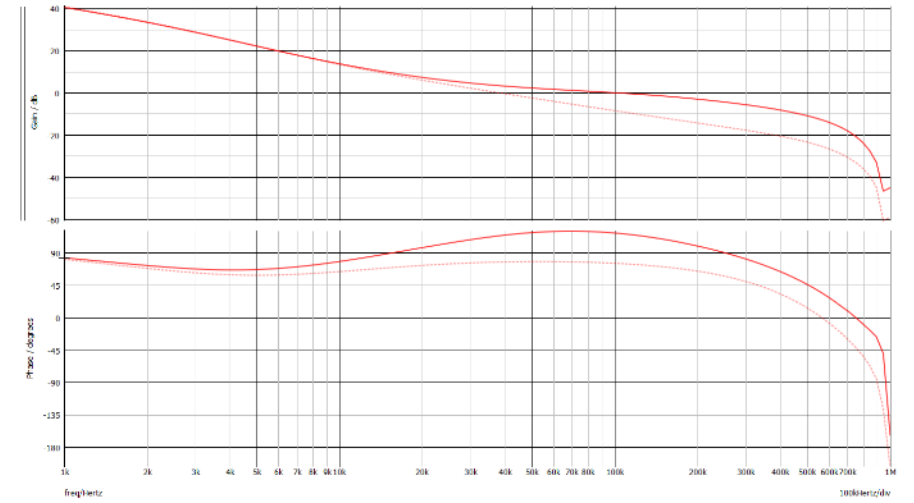
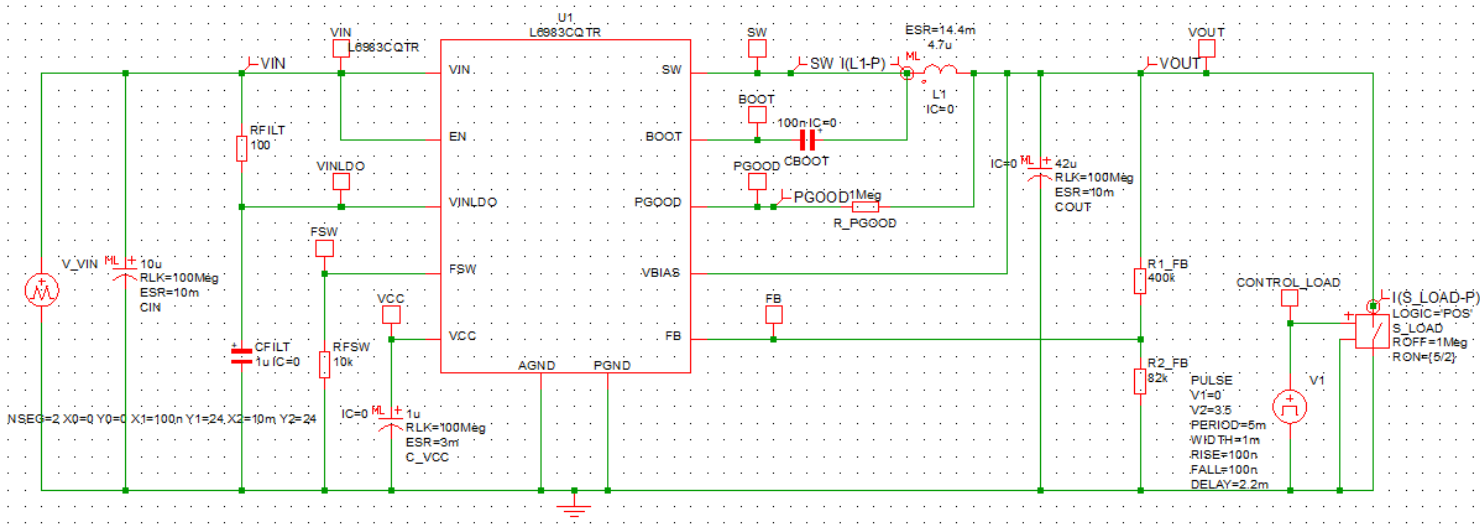

Evaluation board advisor

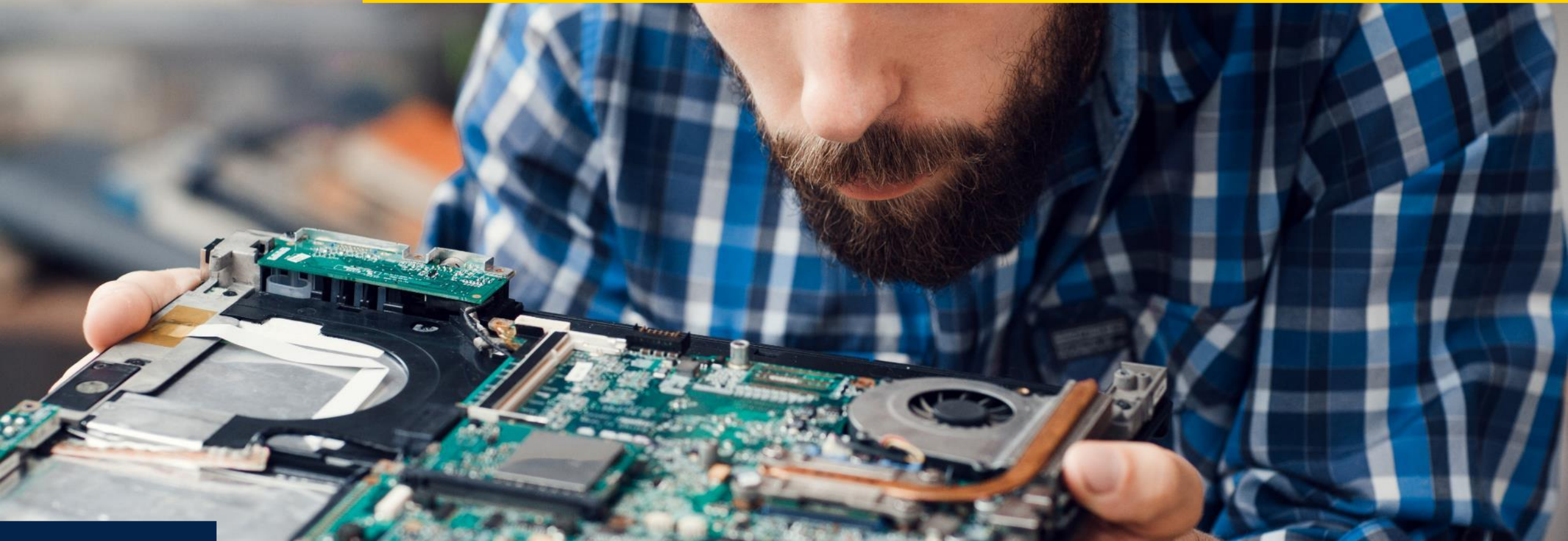

life.augmented

A new capability is now available and used to show **matching** and **additional** boards number.

The **matching boards** are the ones that strictly satisfy user specification.

The **additional boards** are proposed applying **tolerances^(*)** on the user specs, allowing to suggest more boards for our customers.

(*) tolerances can be customized

The button information is refreshed each time the user changes the electrical parameters.

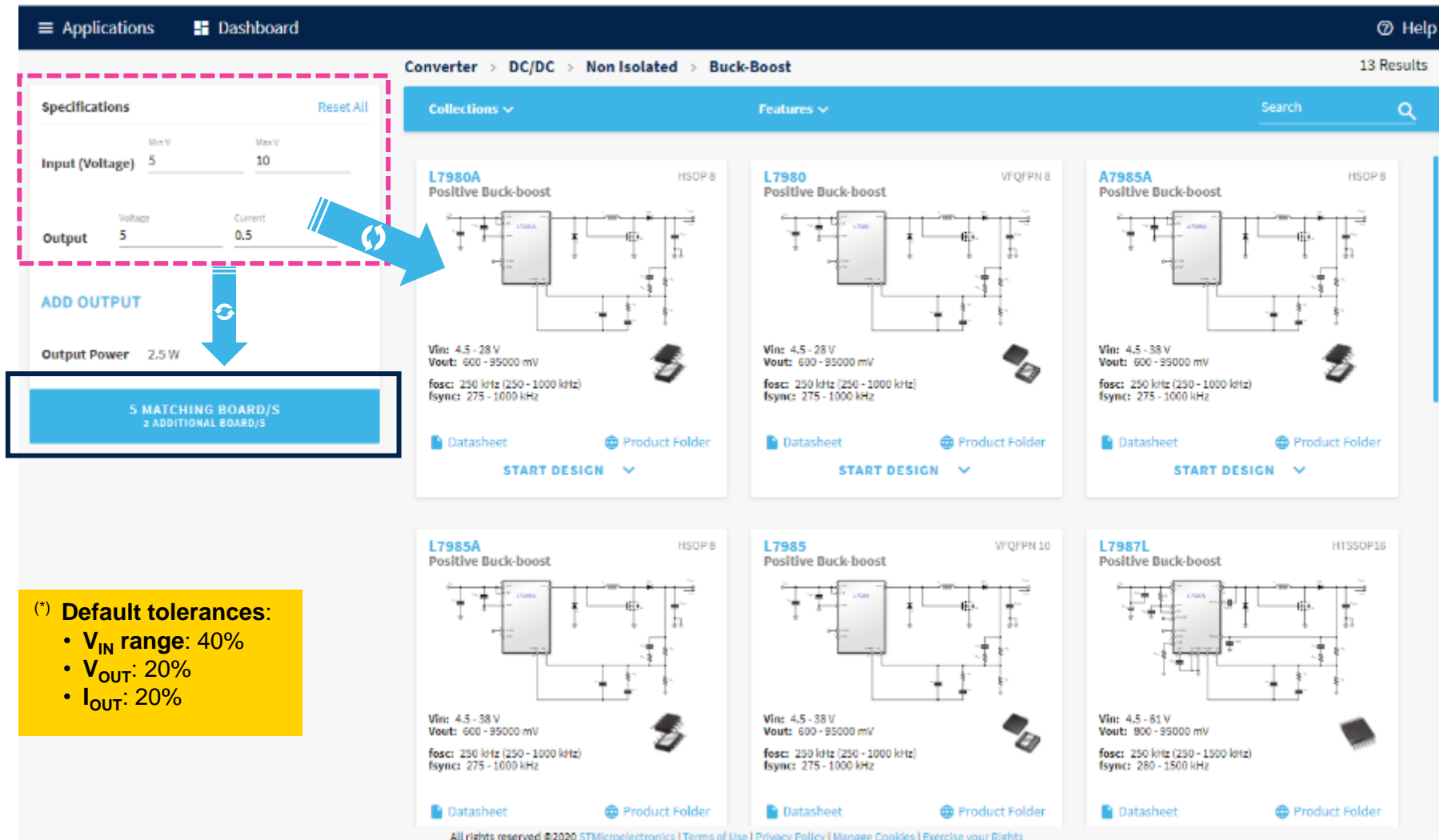

Specifications Reset All

Input (Voltage) Min V Max V

Output Voltage Current

ADD OUTPUT

Output Power 2.5 W

5 MATCHING BOARD/S
2 ADDITIONAL BOARD/S

Converter > **DC/DC** > **Non Isolated** > **Buck-Boost** 13 Results

L7980A Positive Buck-boost HSOP 8

L7980 Positive Buck-boost VQFPN 8

A7985A Positive Buck-boost HSOP 8

L7985A Positive Buck-boost HSOP 8

L7985 Positive Buck-boost VQFPN 10

L7987L Positive Buck-boost HTSSOP16

(*) Default tolerances:

- V_{IN} range: 40%
- V_{OUT} : 20%
- I_{OUT} : 20%

Clicking on the button the evaluation boards dialog will pop up, showing the **matching** and the **additional** boards

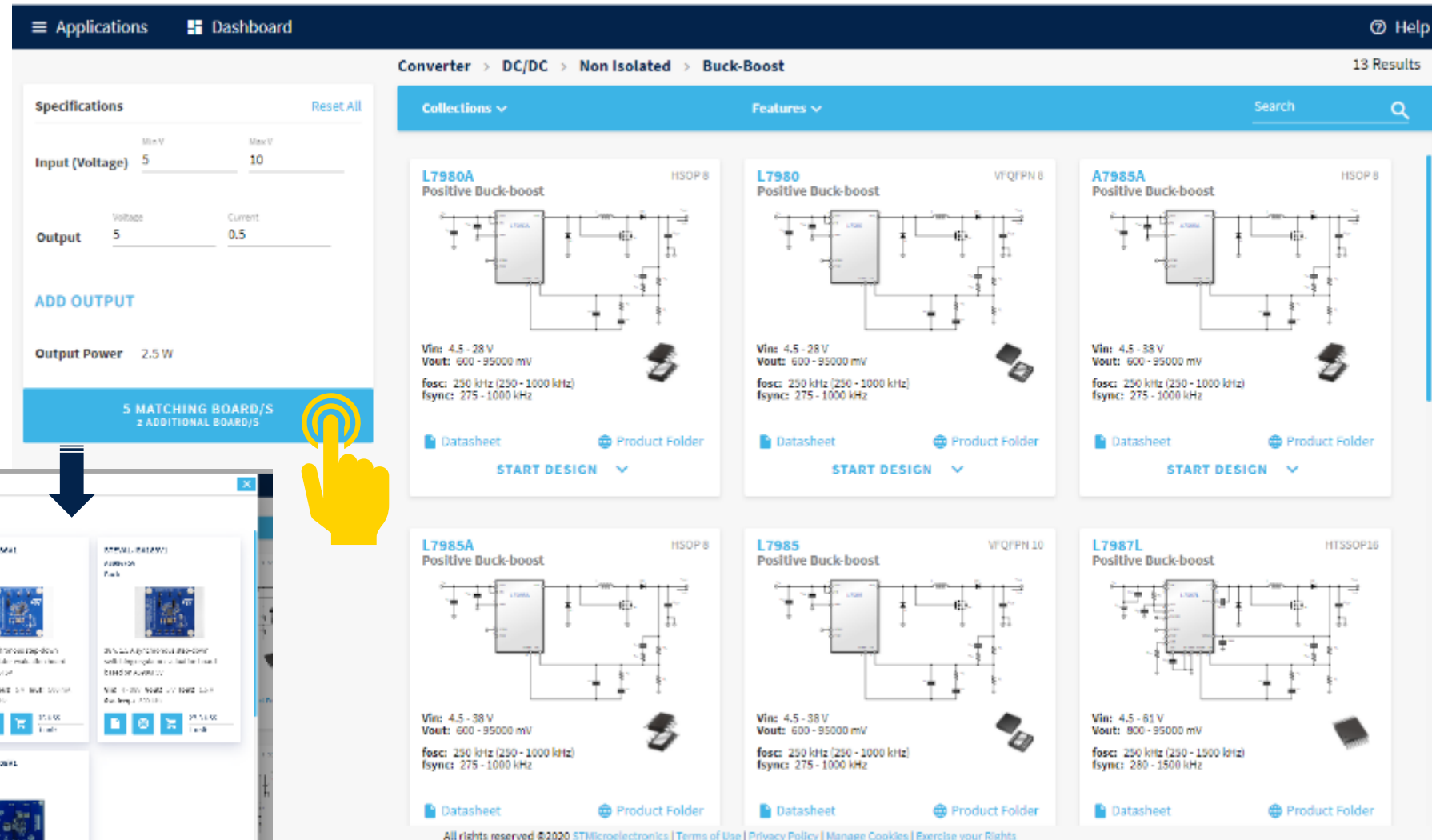

Applications Dashboard

Converter > DC/DC > Non Isolated > Buck-Boost

13 Results

Specifications [Reset All](#)

Input (Voltage)

Output

ADD OUTPUT

Output Power 2.5 W

5 MATCHING BOARD/S
2 ADDITIONAL BOARD/S

L7980A Positive Buck-boost HSOP 8
 Vin: 4.5 - 28 V
 Vout: 600 - 95000 mV
 fosc: 250 kHz (250 - 1000 kHz)
 fsync: 275 - 1000 kHz

L7980 Positive Buck-boost VQFPN 8
 Vin: 4.5 - 28 V
 Vout: 600 - 95000 mV
 fosc: 250 kHz (250 - 1000 kHz)
 fsync: 275 - 1000 kHz

A7985A Positive Buck-boost HSOP 8
 Vin: 4.5 - 38 V
 Vout: 600 - 95000 mV
 fosc: 250 kHz (250 - 1000 kHz)
 fsync: 275 - 1000 kHz

L7985A Positive Buck-boost HSOP 8
 Vin: 4.5 - 38 V
 Vout: 600 - 95000 mV
 fosc: 250 kHz (250 - 1000 kHz)
 fsync: 275 - 1000 kHz

L7985 Positive Buck-boost VQFPN 10
 Vin: 4.5 - 38 V
 Vout: 600 - 95000 mV
 fosc: 250 kHz (250 - 1000 kHz)
 fsync: 275 - 1000 kHz

L7987L Positive Buck-boost HTSSOP16
 Vin: 4.5 - 61 V
 Vout: 800 - 95000 mV
 fosc: 250 kHz (250 - 1500 kHz)
 fsync: 280 - 1500 kHz

START DESIGN

Datasheet Product Folder

All rights reserved ©2020 STMicroelectronics | Terms of Use | Privacy Policy | Manage Cookies | Exercise your Rights



Matching Boards

STPVAL-1234567890
 L7980A
 Positive Buck-boost
 HSOP 8

STPVAL-1234567890
 L7980
 Positive Buck-boost
 VQFPN 8

STPVAL-1234567890
 A7985A
 Positive Buck-boost
 HSOP 8

STPVAL-1234567890
 L7985A
 Positive Buck-boost
 HSOP 8

STPVAL-1234567890
 L7985
 Positive Buck-boost
 VQFPN 10

STPVAL-1234567890
 L7987L
 Positive Buck-boost
 HTSSOP16

Export to CAD



 life.augmented **1. Click** eDesignSuite
Project name: Untitled

Save Export **Export dsn OrCAD** ^{NEW} Export for eDSim Restore Print Disclaimer



Download OrCAD design file

L6983 .zip

DOWNLOAD

2. Download

3. Open with Orcad Capture

Name	Status	Date modified	Type	Size
 L6983C50QTR.dsn		7/25/2022 4:42 AM	DSN File	49 KB



IC: A7987
Topology: INVERTING BUCK-BOOST
Input: 5 - 8 V
Output: 2 V (2% ripple) - 1 A max

min 5 V / max 8 V
@Vin: 8 V
min 205.77 mA / max 1 A
@Iout: 1 A
min -40 °C / max 125 °C
@Ta: 25 °C

Simulation: duty cycle 24.5%
Efficiency: 72.2%
Bode: $f_c = 21.28$ kHz - phase margin = 68.7%

OrCAD Capture-UI - (SCHEMATIC1 - PAGE1) (Read Only)

File Design Edit View Tools Place PCB SI Analysis PSpice Accessories Options Window Help

7987.opj (Read Only) / (SCHEMATIC1 - PAGE1) (Read Only)

IC: A7987
VIN1: 5 V - 8 V
VIN2: 10 μ F
VOUT: 2 V
ILIM: 1.89 A
L: 6.8 μ H
COUT: 220 μ F
CIN: 10 μ F
CINA: 1 μ F
RIN: 0 Ohm
CBOOT: 100 nF
CBIAS: 1 μ F
CC: 22 nF
RC: 10 kOhm
CP: 68 pF
RFB: 110 kOhm
RC2: 4.7 kOhm
RL: 73.2 kOhm
RFSW: 51.1 kOhm
RLIM: 36 kOhm
CPS: 12 nF

Power tree designer





eDesignSuite

eDesignSuite changes face Link to launch power tree designer

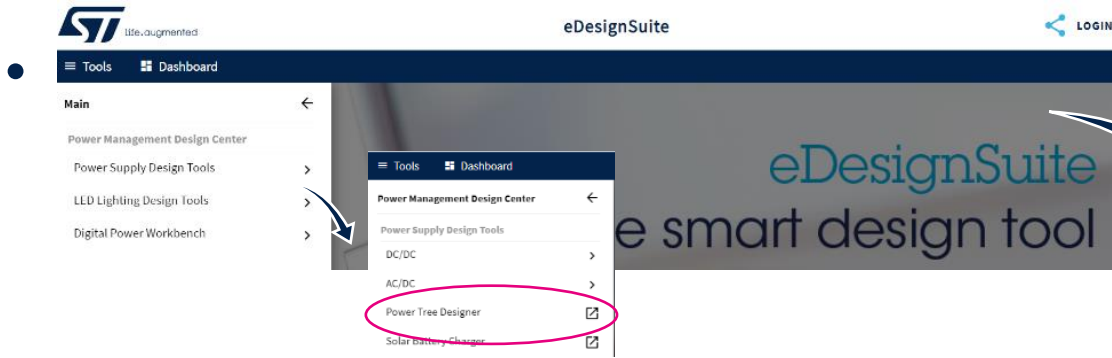

...also from product family page



eDesignSuite is a comprehensive set of easy-to-use design-aid utilities ready to help you streamline the system development process with a wide range of ST products.

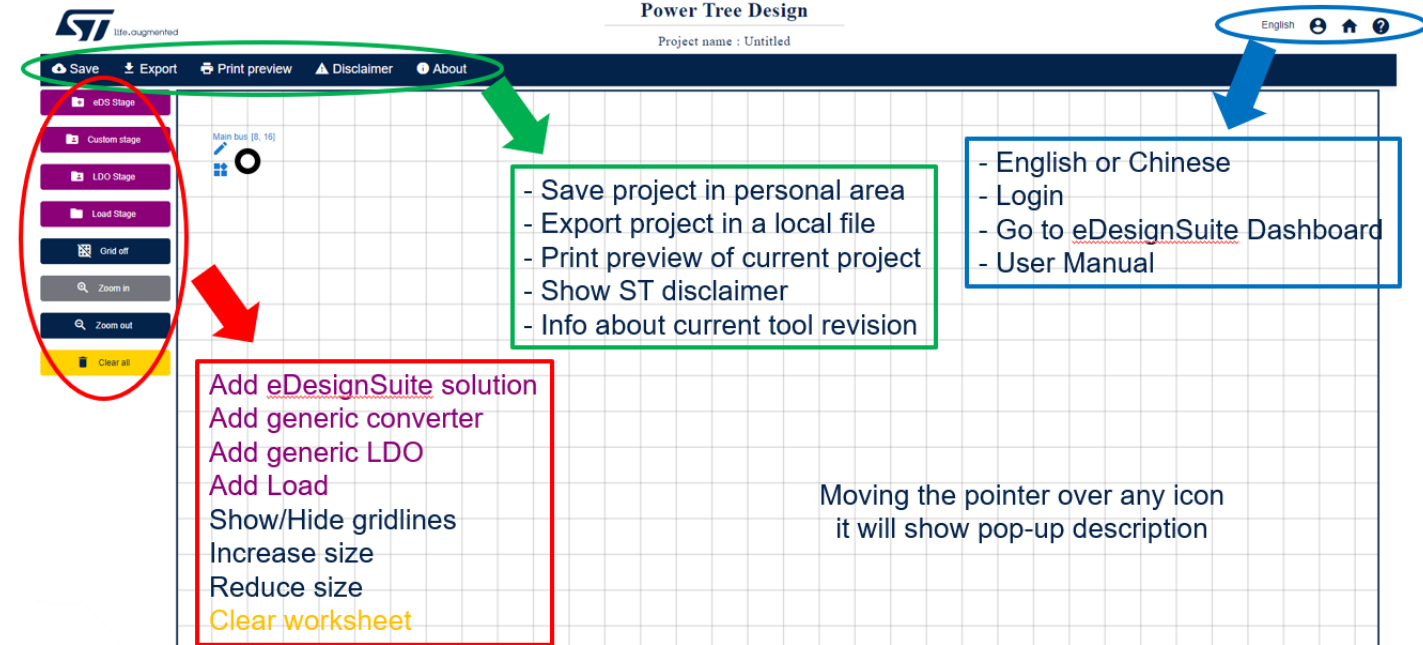
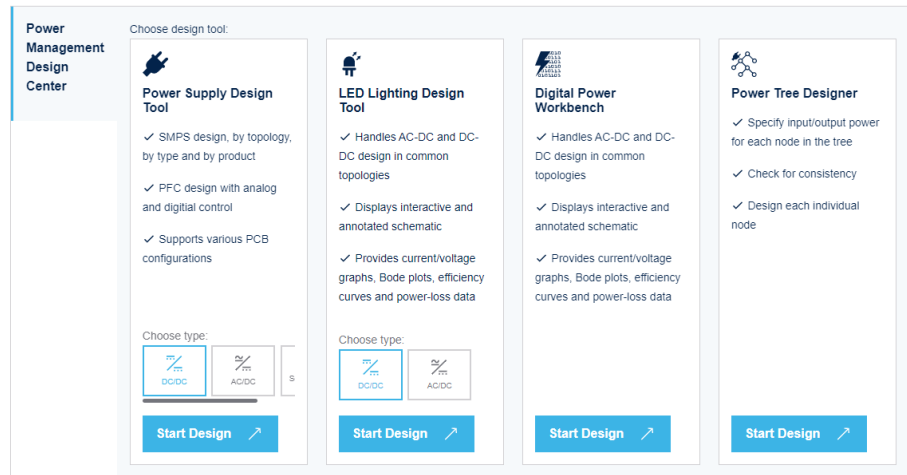

- Save project in personal area
- Export project in a local file
- Print preview of current project
- Show ST disclaimer
- Info about current tool revision

- English or Chinese
- Login
- Go to eDesignSuite Dashboard
- User Manual

- Add eDesignSuite solution
- Add generic converter
- Add generic LDO
- Add Load
- Show/Hide gridlines
- Increase size
- Reduce size
- Clear worksheet

Moving the pointer over any icon it will show pop-up description



A complete DC-DC power map

Design

Top-Down approach

- Configure the **main bus**
- Add **new stages**, connect them to the main bus or other power stages
- Add a **load stage** at the end of each branch



Analyze

Collect several usage cases' simulations

- Set multiple **V_{IN} conditions** and run it (i.e. Typ, min, max)
- Copy to benchmark in one single table



Report

Save outcomes and print all together

- It includes **all the information** & computed results from main bus to loads
- For eDesignSuite stages there are: **Schematic**, **BOM** and **efficiency chart**
- For other stages there is a **textual description**

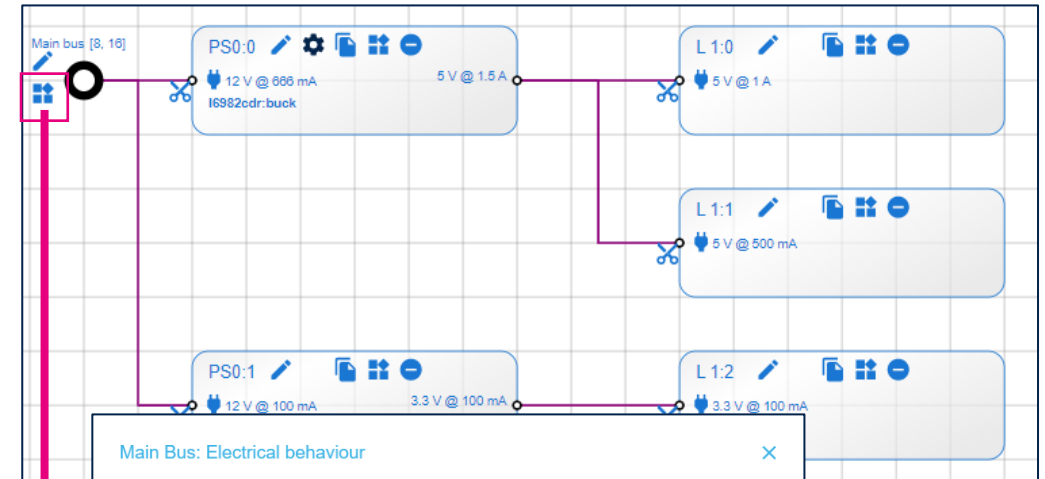

Main Bus: Electrical behaviour

Please change the Nominal Input Voltage to observe the power tree electrical behaviour.

Analysis Section:

Nom. Vin V Analyze Power Tree

Result Section

Stage's name	Vin	Pout	Pin	Iin	I/O Efficiency	Losses
Main bus	12 V	10.28 W	13.88 W	1.16 A	74.02 %	3.61 W

Delete all results Copy Result

Results table by power branch

Result at different nominal voltage

Stage's name	Vin	Pout	Pin	Iin	I/O Efficiency	Losses
Main bus	8 V	10.28 W	13.77 W	1.72 A	74.64 %	3.49 W
Main bus	12 V	10.28 W	13.88 W	1.16 A	74.02 %	3.61 W
Main bus	16 V	10.28 W	14.01 W	876 mA	73.33 %	3.74 W

Digital Power WorkBench

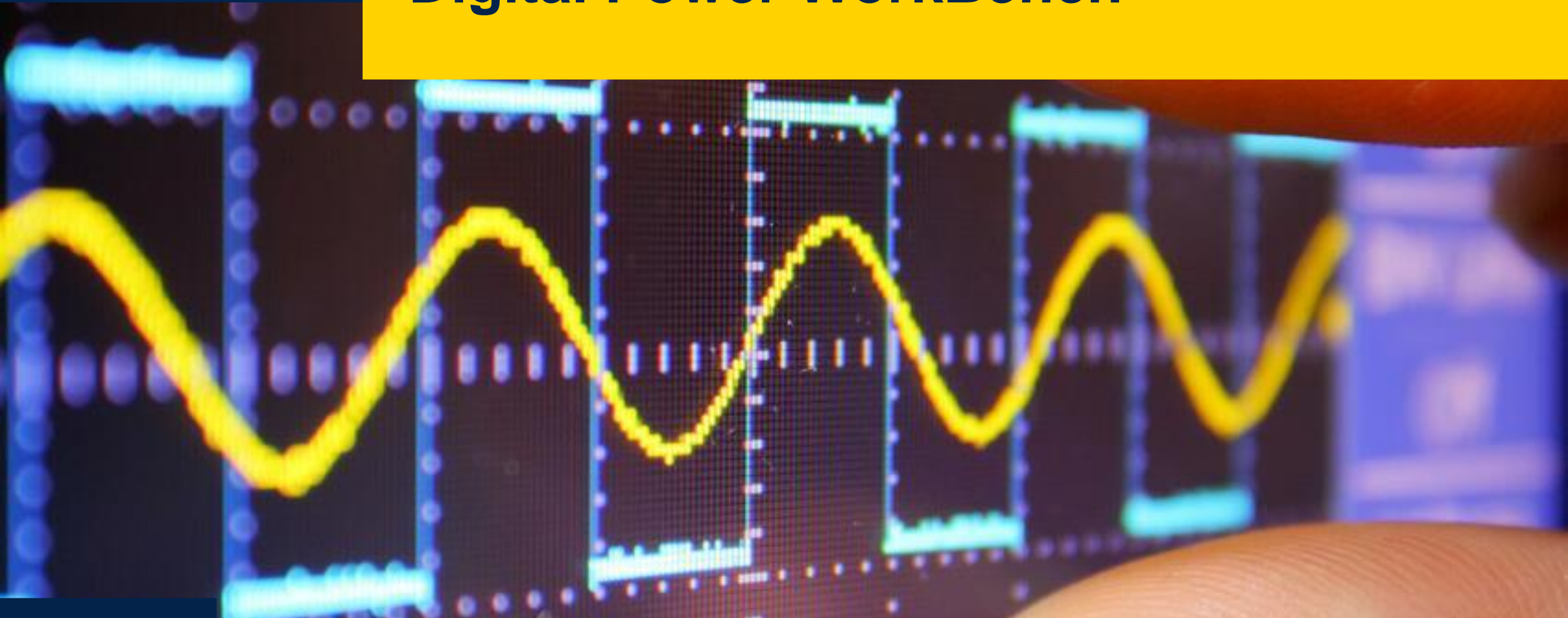



Digital power WorkBench in eDesignSuite

Fully graphical user interface for high power solutions



Power stage optimizer



Digital control loop designer



STM32 FW generator



Evaluation board selector

Supported topologies (AC/DC, DC/DC)

- ZVS Interleaved Totem-Pole, Vienna Rectifier, 3-Level T-Type Converter
- FB LLC, DAB (development)



Digital Power WorkBench supported topologies

FB LLC
(500 – 5000 W)

**Vienna PFC Rectifier
Bidir 3L T-type PFC**
(6 – 20 kW)

ZVS Totem-Pole PFC
(330 – 3300 W)

Dual Active Bridge
(6 – 30 kW)

**Bidirectional
Totem-Pole**
(3 – 11 kW)
Full SiC solution

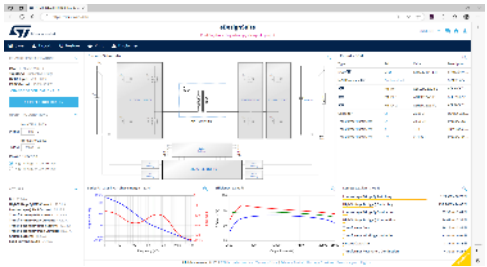
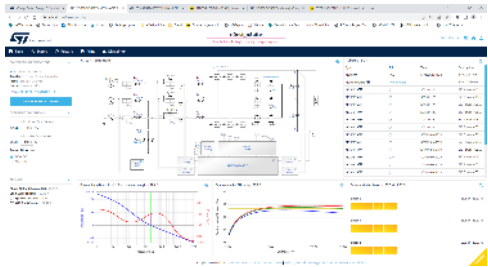
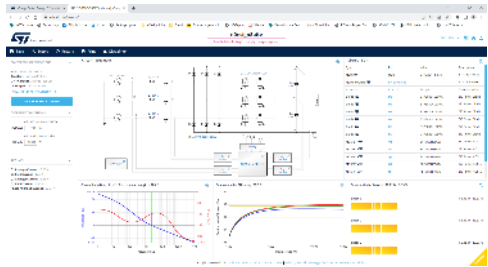
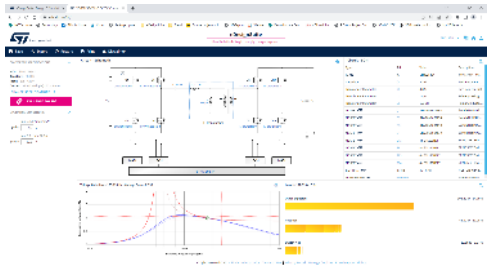

**Bidirectional
CLLC**
(3 – 11 kW)
Full SiC solution

Power stage optimizer



STM32F3

- Full SJ solution

**DPC compatibility with
STM32Cube, signal
conditioning eDSim
simulation**



STM32G4

- Full SiC solution

**DPC compatibility with
STM32Cube, signal
conditioning eDSim
simulation**



STM32G4

- Full SJ solution

**DPC Bidirectional power
flow, STPOWER Studio
connection**

AVAILABLE SOON



STM32G4

- Full SiC solution

AVAILABLE SOON

2021

2022

2023

GUI

- Schematic view, BOM, Bode Diagrams, Power losses (for Power Transistors and Diodes)
- Wizard based design customization

Hardware sizing

- Magnetics, power switch selection, diodes selection, current Loop and voltage loop compensation

Firmware customization

- Sensing, protections, voltage control and Current Control

Firmware delivery

- Compatibility with STM32Cube tools: delivery of custom STM32Cube expansion pack for Vienna Rectifier solution + STM32CubeMX project (.ioc file) reflecting all current solution customization

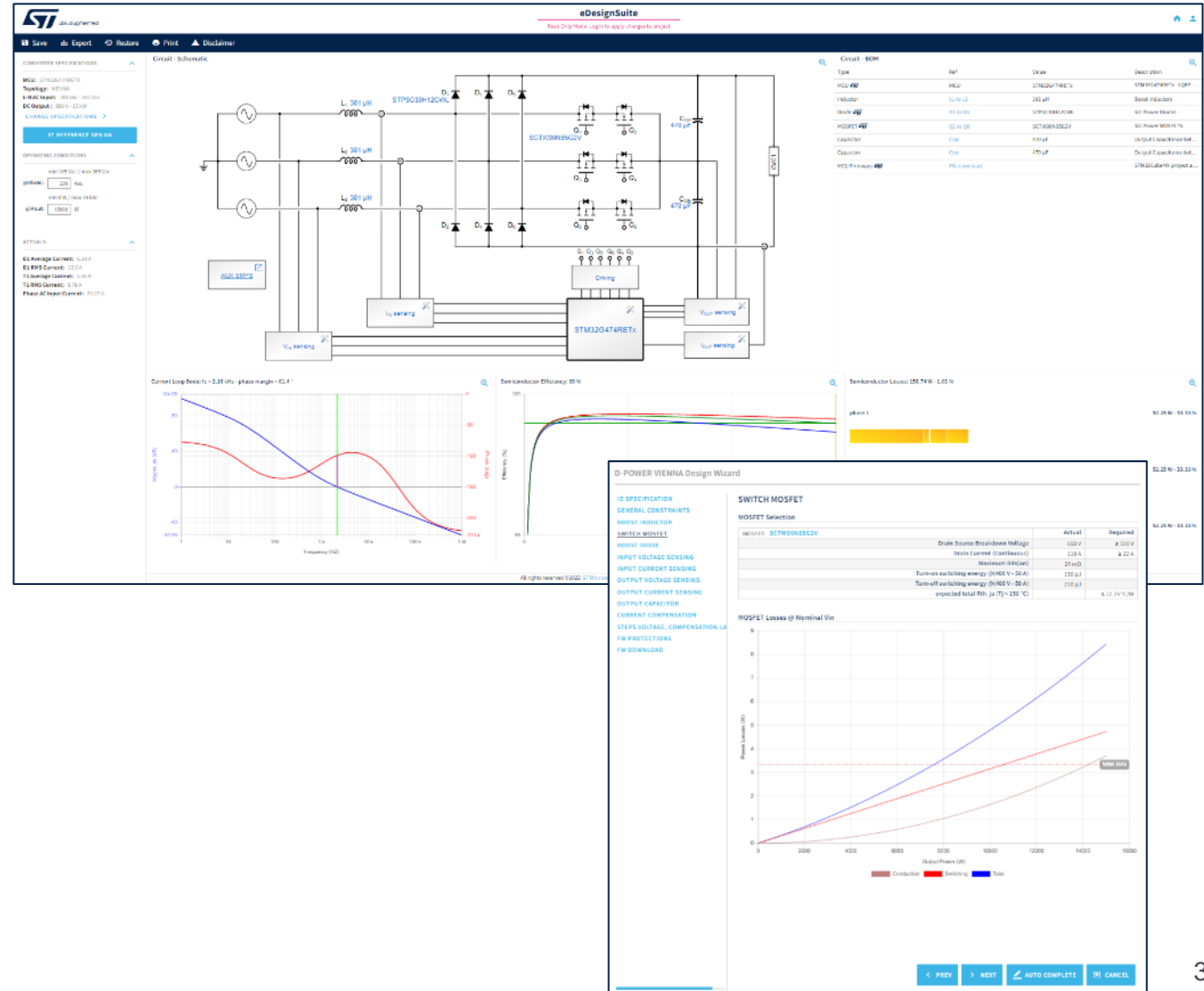

The screenshot displays the eDesignSuite software interface for a D-POWER VIENNA Design Wizard. The main window shows a circuit schematic of a Vienna Rectifier topology. The schematic includes an input filter with three inductors (L1, L2, L3) and three capacitors (C1, C2, C3), followed by a three-phase diode bridge (STPSC30H12GWL), a three-phase IGBT inverter (SCTW085G2V), and an output filter with an inductor (L4) and a capacitor (C4). The inverter is driven by an STM32G474RETx microcontroller.

On the right side, a BOM (Bill of Materials) table is visible:

Part	Ref	Value	Description
IGBT	IGBT1	320V	IGBT
Diode	Diode1	1200V	Diode
Diode	Diode2	1200V	Diode
Diode	Diode3	1200V	Diode
Diode	Diode4	1200V	Diode
Diode	Diode5	1200V	Diode
Diode	Diode6	1200V	Diode
Diode	Diode7	1200V	Diode
Diode	Diode8	1200V	Diode
Diode	Diode9	1200V	Diode
Diode	Diode10	1200V	Diode
Diode	Diode11	1200V	Diode
Diode	Diode12	1200V	Diode
Diode	Diode13	1200V	Diode
Diode	Diode14	1200V	Diode
Diode	Diode15	1200V	Diode
Diode	Diode16	1200V	Diode
Diode	Diode17	1200V	Diode
Diode	Diode18	1200V	Diode
Diode	Diode19	1200V	Diode
Diode	Diode20	1200V	Diode
Diode	Diode21	1200V	Diode
Diode	Diode22	1200V	Diode
Diode	Diode23	1200V	Diode
Diode	Diode24	1200V	Diode
Diode	Diode25	1200V	Diode
Diode	Diode26	1200V	Diode
Diode	Diode27	1200V	Diode
Diode	Diode28	1200V	Diode
Diode	Diode29	1200V	Diode
Diode	Diode30	1200V	Diode
Diode	Diode31	1200V	Diode
Diode	Diode32	1200V	Diode
Diode	Diode33	1200V	Diode
Diode	Diode34	1200V	Diode
Diode	Diode35	1200V	Diode
Diode	Diode36	1200V	Diode
Diode	Diode37	1200V	Diode
Diode	Diode38	1200V	Diode
Diode	Diode39	1200V	Diode
Diode	Diode40	1200V	Diode
Diode	Diode41	1200V	Diode
Diode	Diode42	1200V	Diode
Diode	Diode43	1200V	Diode
Diode	Diode44	1200V	Diode
Diode	Diode45	1200V	Diode
Diode	Diode46	1200V	Diode
Diode	Diode47	1200V	Diode
Diode	Diode48	1200V	Diode
Diode	Diode49	1200V	Diode
Diode	Diode50	1200V	Diode
Diode	Diode51	1200V	Diode
Diode	Diode52	1200V	Diode
Diode	Diode53	1200V	Diode
Diode	Diode54	1200V	Diode
Diode	Diode55	1200V	Diode
Diode	Diode56	1200V	Diode
Diode	Diode57	1200V	Diode
Diode	Diode58	1200V	Diode
Diode	Diode59	1200V	Diode
Diode	Diode60	1200V	Diode
Diode	Diode61	1200V	Diode
Diode	Diode62	1200V	Diode
Diode	Diode63	1200V	Diode
Diode	Diode64	1200V	Diode
Diode	Diode65	1200V	Diode
Diode	Diode66	1200V	Diode
Diode	Diode67	1200V	Diode
Diode	Diode68	1200V	Diode
Diode	Diode69	1200V	Diode
Diode	Diode70	1200V	Diode
Diode	Diode71	1200V	Diode
Diode	Diode72	1200V	Diode
Diode	Diode73	1200V	Diode
Diode	Diode74	1200V	Diode
Diode	Diode75	1200V	Diode
Diode	Diode76	1200V	Diode
Diode	Diode77	1200V	Diode
Diode	Diode78	1200V	Diode
Diode	Diode79	1200V	Diode
Diode	Diode80	1200V	Diode
Diode	Diode81	1200V	Diode
Diode	Diode82	1200V	Diode
Diode	Diode83	1200V	Diode
Diode	Diode84	1200V	Diode
Diode	Diode85	1200V	Diode
Diode	Diode86	1200V	Diode
Diode	Diode87	1200V	Diode
Diode	Diode88	1200V	Diode
Diode	Diode89	1200V	Diode
Diode	Diode90	1200V	Diode
Diode	Diode91	1200V	Diode
Diode	Diode92	1200V	Diode
Diode	Diode93	1200V	Diode
Diode	Diode94	1200V	Diode
Diode	Diode95	1200V	Diode
Diode	Diode96	1200V	Diode
Diode	Diode97	1200V	Diode
Diode	Diode98	1200V	Diode
Diode	Diode99	1200V	Diode
Diode	Diode100	1200V	Diode

Below the schematic, there are several graphs and data points:

- Current Loop Bode Plot:** Shows magnitude and phase margin. The phase margin is 62.4°.
- Switching Efficiency Plot:** Shows efficiency (%) vs. frequency (Hz). The efficiency is 95%.
- Power Losses Plot:** Shows power losses (W) vs. output power (W). The total power loss is 1.07 W.

The D-POWER VIENNA Design Wizard window is also visible, showing the MOSFET selection table:

Parameter	Actual	Required
Drain-Source Breakdown Voltage	650V	≥ 500V
Drain Current (Continuous)	22.8A	≥ 22.8A
Maximum dI/dt	250A/μs	
Turn-on switching energy (90KEV - 50A)	130 μJ	
Turn-off switching energy (90KEV - 50A)	237 μJ	
expected total ESW (at 75 - 150 °C)	6.17 mJ/M	

At the bottom of the wizard window, there is a graph showing MOSFET Losses (W) vs. Output Power (W). The losses are categorized into Conduction (red), Switching (blue), and Total (green).

FW generation and delivery workflow

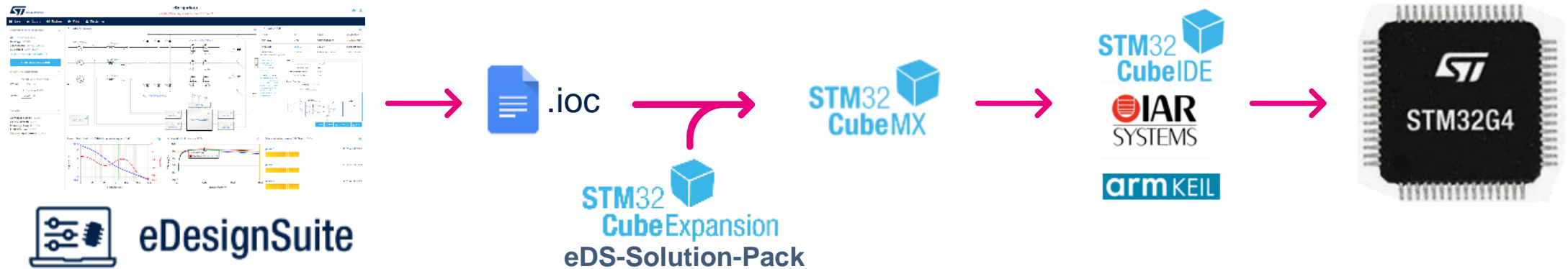

Firmware delivery

Compatibility with STM32Cube tools: delivery of custom STM32Cube expansion pack for Vienna Rectifier solution + STM32CubeMX project (.ioc file) reflecting all current solution customization

Break the 99% efficiency barrier in Digital Power STEVAL-TTPPFC01

2 kW interleaved totem-pole PFC with resonant ZVS digital control,
based on STM32G4 and SJ MDmesh DM9 Power MOSFETs

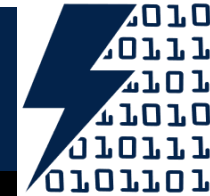

99.3% peak efficiency,
>99.1 % flat efficiency from 30% load,
bias losses all included

Eases compliance to **80 Plus
Titanium spec** and thermal
design: heatsink-free cooling

Sophisticated digital hysteresis
current-mode control

Flexible to implement ZVS,
TM (CrM) and CCM mode

Multi-cell configuration with
superposition of inductor currents

Reduced input current ripple,
higher density

25 kW DAB reference design for EV charging, ESS, UPS : STDES-VRECTFD

Bidirectional DAB - Dual Active Bridge Converter with SiC Power Modules and Digital Control

Key features

- Optimized integration and thermal dissipation
- Extended soft switching mode, thanks to sophisticated modulation
- Bidirectional digital power control
- Peak efficiency: 98.4%

Key products

- **A2F12M12W2-F1** (ACEPACK™ 2 – Full-bridge - 1200V, 12mΩ SiC MOSFET Gen2 and NTC)
- **A2H6M12W3-F*** (ACEPACK™ 2 – Half-bridge - 1200V, 6mΩ SiC MOSFET Gen3 and NTC)
- **STGAP2SICS** (Galvanically isolated 4 A single gate driver for SiC MOSFETs)
- **STM32G474** (Cortex-M4+ 32-bit MCU)

* Coming soon, AIN version with high thermal performance available

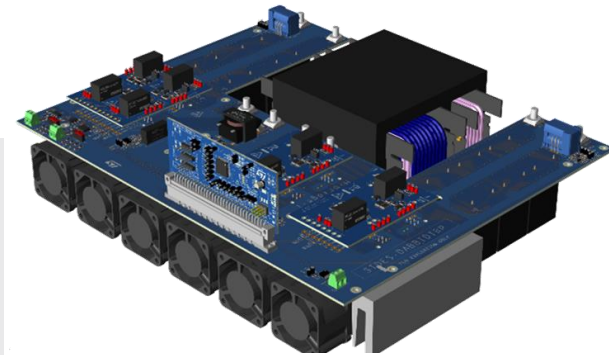

Electrical specs

- Nominal DC high voltage: 800 V
- Nominal DC low voltage: 400 V
- Switching frequency: 100 kHz

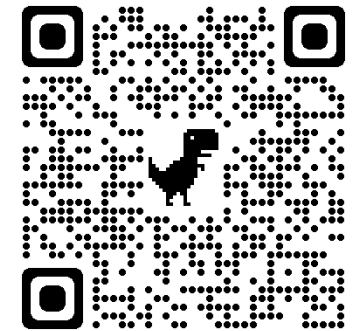

15 kW VIENNA rectifier reference design for EV charging: STDES-VRECTFD

3-Level converter with SiC and Full Digital Control

Key features

- Power section based on SiC MOSFETs and SiC diodes
- High peak efficiency, > 98%
- Passive element weight and size reduction
- Control section based on STM32G4 32-bit MCU for digital power
- Fast dynamic current control with customizable digital voltage regulator

Key products

- **SCTW35N65G2V** (55 mΩ - 650 V SiC MOSFET)
- **STGAP2SICS** (Galvanic isolated gate driver)
- **STM32G474** (Cortex-M4+ 32-bit MCU)
- **STPSC20H12WL** (20 A - 1200 V SiC Diode)
- **VIPer26HD** (High voltage converter)
- **STLM20W87F** (Analog temperature sensor)
- **TSV91x** (Wide-bandwidth Rail to Rail Op-Amps)



Electrical specs

- Output DC voltage: 800 VDC
- Input AC voltage: 400 VAC
- Switching frequency: 70 kHz
- Power factor: >0.99
- THD: <5% at nominal operation

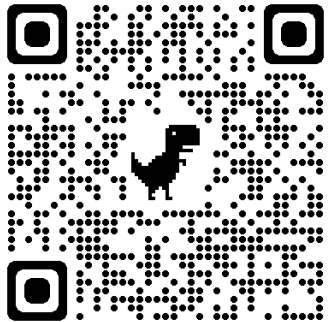
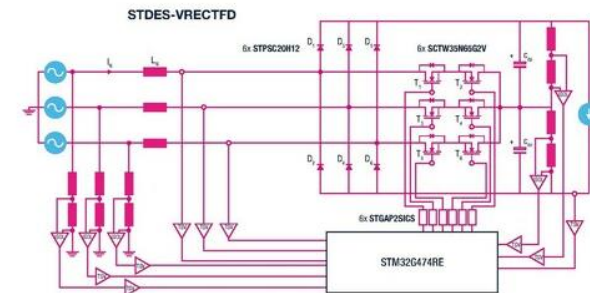

15 kW 3-Level T-Type reference design for EV Charging STDES-PFCBIDIR

Bidirectional converter with SiC and Full Digital Control

Key features

- Active and reactive power control in DC to AC inverter mode
- PF > 0.99, THD < 5% in AC-DC rectifier mode
- Full-digital Voltage Oriented Control - VOC control strategy
- Fast-dynamic bi-directional current-decoupling control

Key products

- **SCTW35N65G2V** (55 mΩ - 650 V SiC MOSFET)
- **SCTW40N120G2V** (75 mΩ - 1200 V SiC MOSFET)
- **STGAP2S** (Galvanic isolated gate driver)
- **STM32G474** (Cortex-M4+ 32-bit MCU)
- **VIPer26HD** (High voltage converter)
- **STLM20W87F** (Analog temperature sensor)
- **TSV91x** (Wide-bandwidth Rail to Rail Op-Amps)

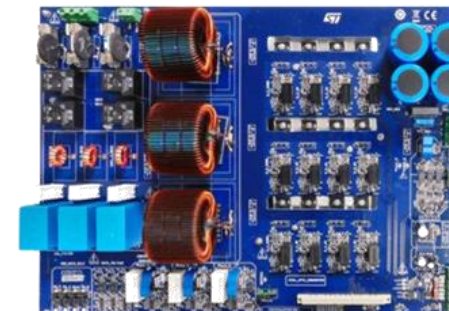

Electrical specs

- Rated nominal DC voltage: 800 VDC
- Rated nominal AC voltage: 400 VAC
- Switching frequency: 70 kHz
- Power factor: >0.99
- THD: <5% at nominal operation

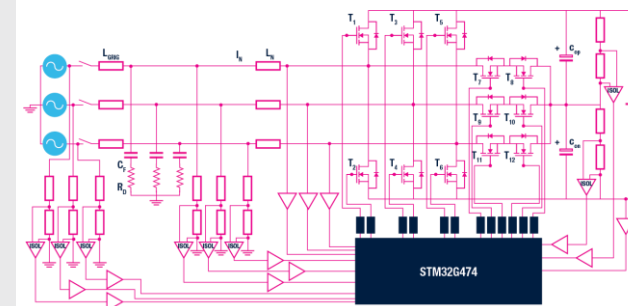



STPOWER Studio



STPOWER Studio

The new dynamic electro-thermal simulation software dedicated to STPOWER devices

STPOWER Studio (former ST PowerStudio), the dynamic electro-thermal simulation software dedicated to STPOWER devices, provides a comprehensive power and thermal analysis able to predict the device performance, shortening the solution design and saving time and resources. Furthermore, the tool helps to select the proper device fitting the application mission profile.

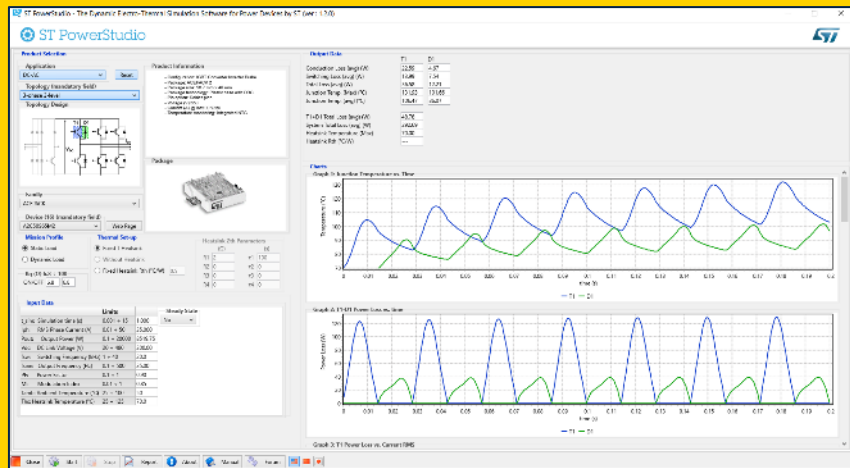

Offline version



Online on eDesignSuite

will be terminated within July '22





STPOWER Studio overview

Now online on eDesignSuite



Scope:

- Online on ST's eDesignSuite platform
- Supports SLLIMM & ACEPACK families
- Enables DC/AC 3-phase 2-level application



Comprehensive Analysis:

- Static load mission profile
- Several thermal setup
- Deep analysis of junction temperatures

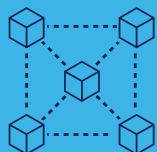

High Connectivity:

- Multilanguage (English, Chinese, Japan)
- Link to device doc (product page, DS)
- Possibility to save and export the project
- Output Report

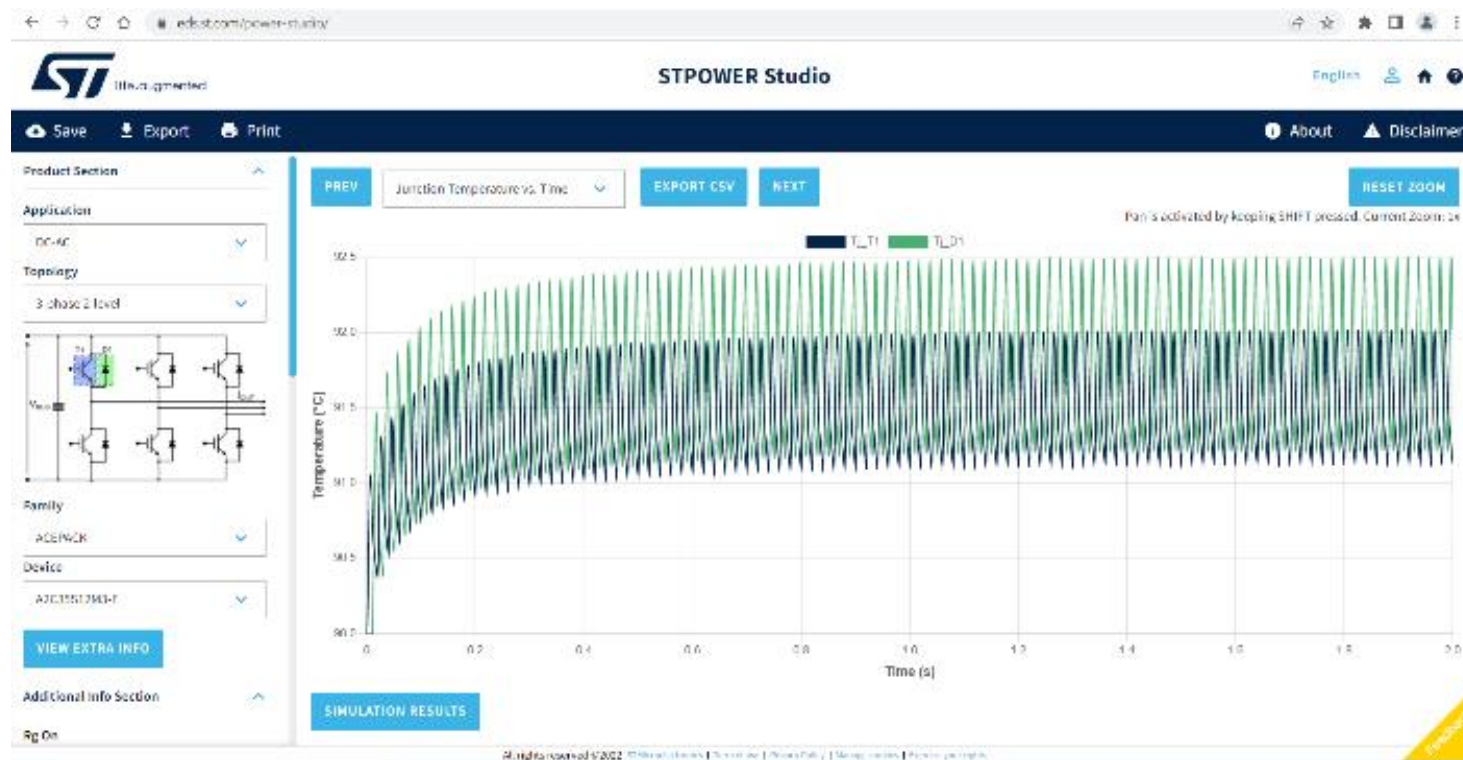

[Go to STPOWER Studio](#)



Takeaway

Get inspired and see what you can do on eDesignSuite

Smart

Make easy and smooth any electrical design, from user's specification to circuit's analysis and customization

Powerful

Provide support on critical design decision effectively reducing risks and avoiding safety hazards

Innovative

SW environment able to support engineers in multiple stages of their system design



eDesignSuite

Our technology starts with You



Find out more at www.st.com

© STMicroelectronics - All rights reserved.

ST logo is a trademark or a registered trademark of STMicroelectronics International NV or its affiliates in the EU and/or other countries.

For additional information about ST trademarks, please refer to www.st.com/trademarks.

All other product or service names are the property of their respective owners.



life.augmented