

Introduction to Automotive Ambient Lighting Solution With ISELED[®] and ILaS[®] Interface



A Leading Provider of Smart, Connected and Secure Embedded Control Solutions



SMART | CONNECTED | SECURE

Presented by
Kenny Shin, Senior Embedded Solutions Engineer
December 19, 2023

Yesterday vs. Today



Smart Ambient LED Lighting



Challenge

- The manufacturing process of RGB lighting is complex
- Innovation together with lighting concept has been a challenging domain



💡 **ISELED® Alliance and Microchip is solving the issue by bringing the ease of manufacturing and innovation together**

ISELED® Alliance

ISELED ALLIANCE MEMBERS



Legacy vs. ISELED[®]

Legacy RGB LED Lighting

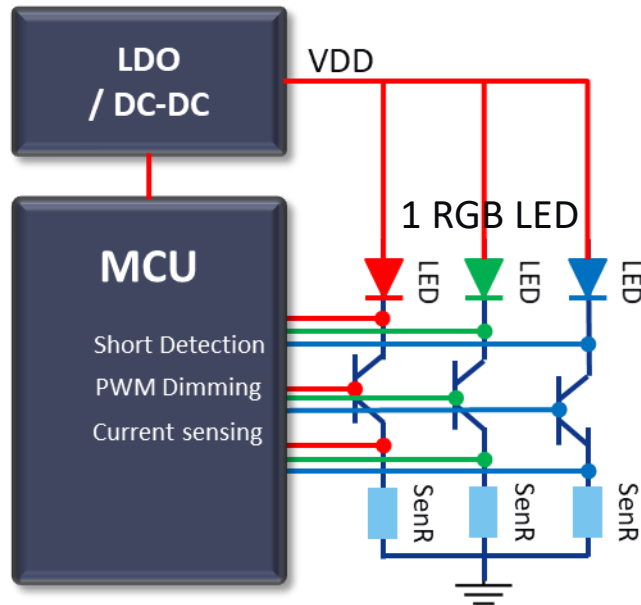

Controller requires at least 9 ports for 1 RGB LED control

ISELED RGB LED Lighting

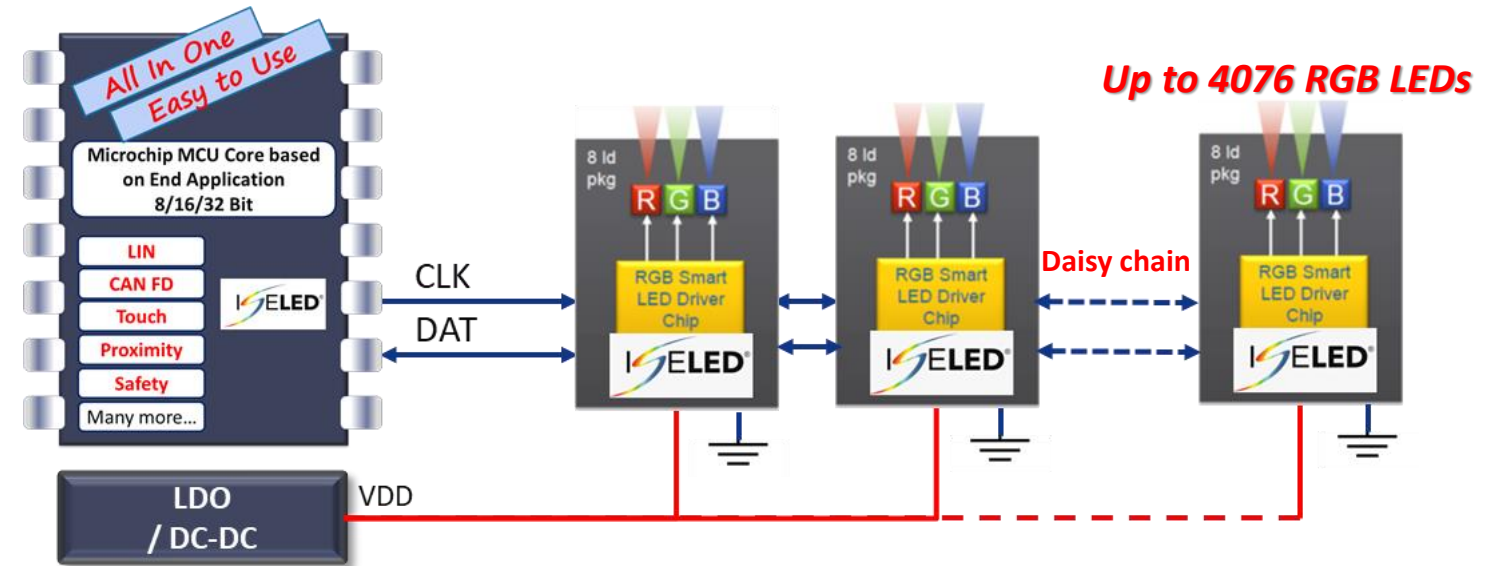

2 ports are sufficient for RGB LED control/Simple Layout/Components Reduction

ISELED® Control with Microchip Microcontroller

What is ISELED Control?

- It is a combination of three LED chips (red, green, blue) and an ASIC which controls the LEDs plus doing the communication in one package
- Binning and calibrated RGB LEDs
- Increases speed for enabling dynamic Light effects
- The ISELEDs are connected in series as a LED chain

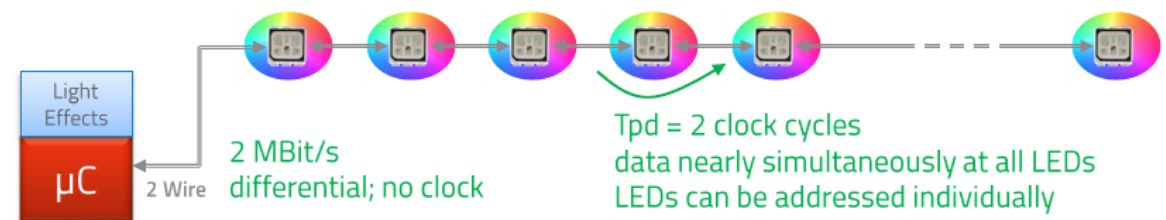
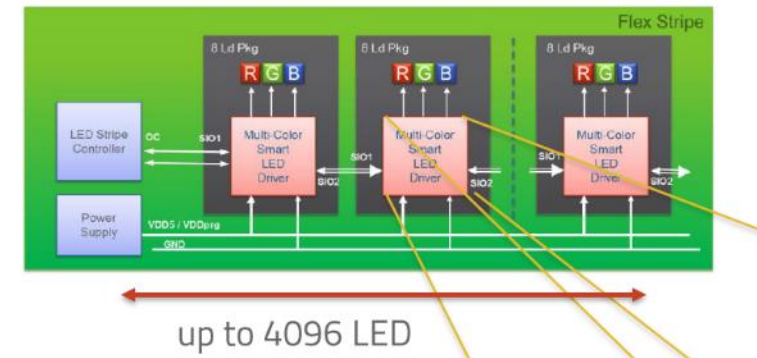
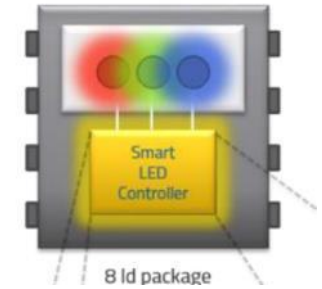

ISELED® Solution

Advantages

- Uses only FOUR wires (DAT, CLK, 5V, GND)
- Digitally addressable
- Smart RGB LED modules with integrated smart LED driver
- Serial daisy-chain bus (*Up to 2Mbps)
- Up to 4079 ISELED connections
- LED Open/Short Detection
- Factory calibration for color
- Temperature compensation automatically

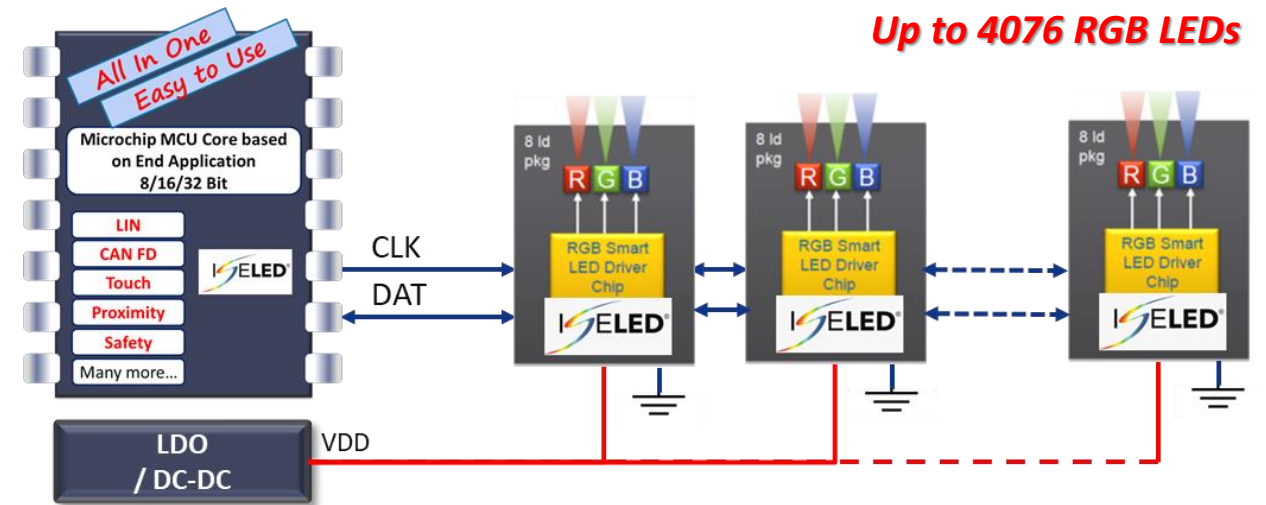

*Updating every single LED in a chain with 100 LEDs is performed in 5.25ms, allowing frame rates of over 100Hz.

ISELED® Application



Suited based on End Application

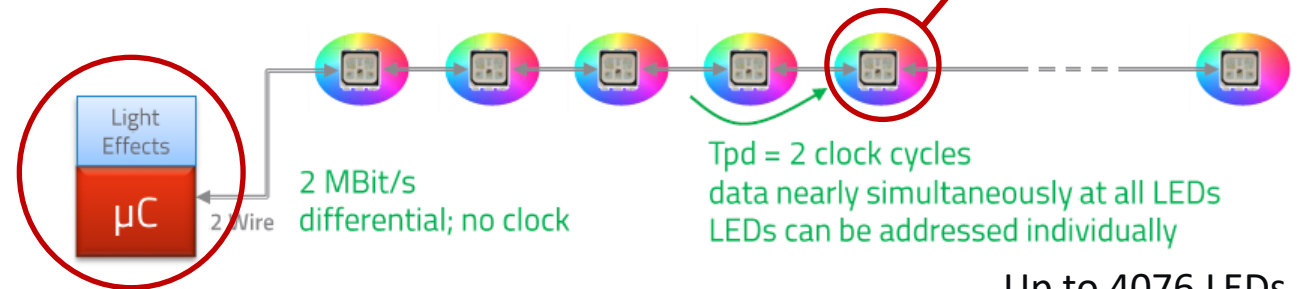
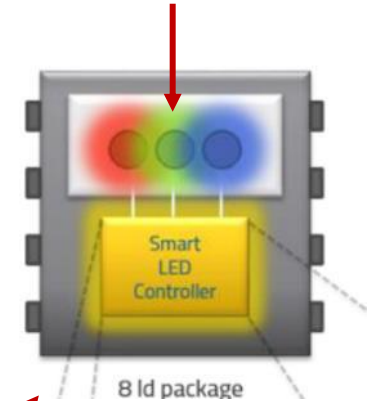
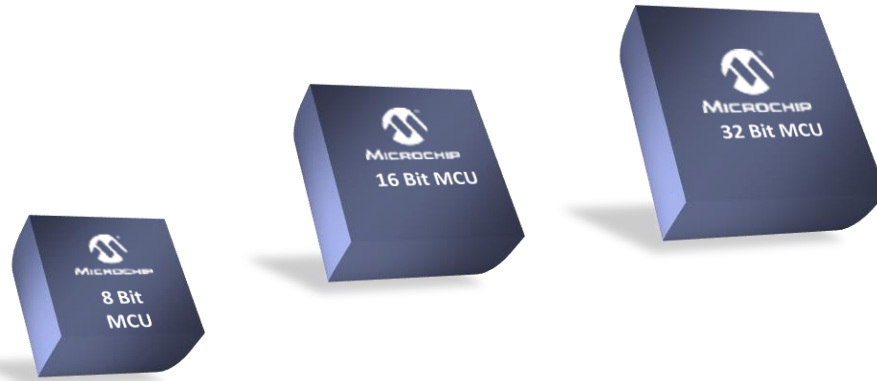

Up to 4076 LEDs

ISELED®/ILaS® Core Independence

All-in-one

Easy-to-use

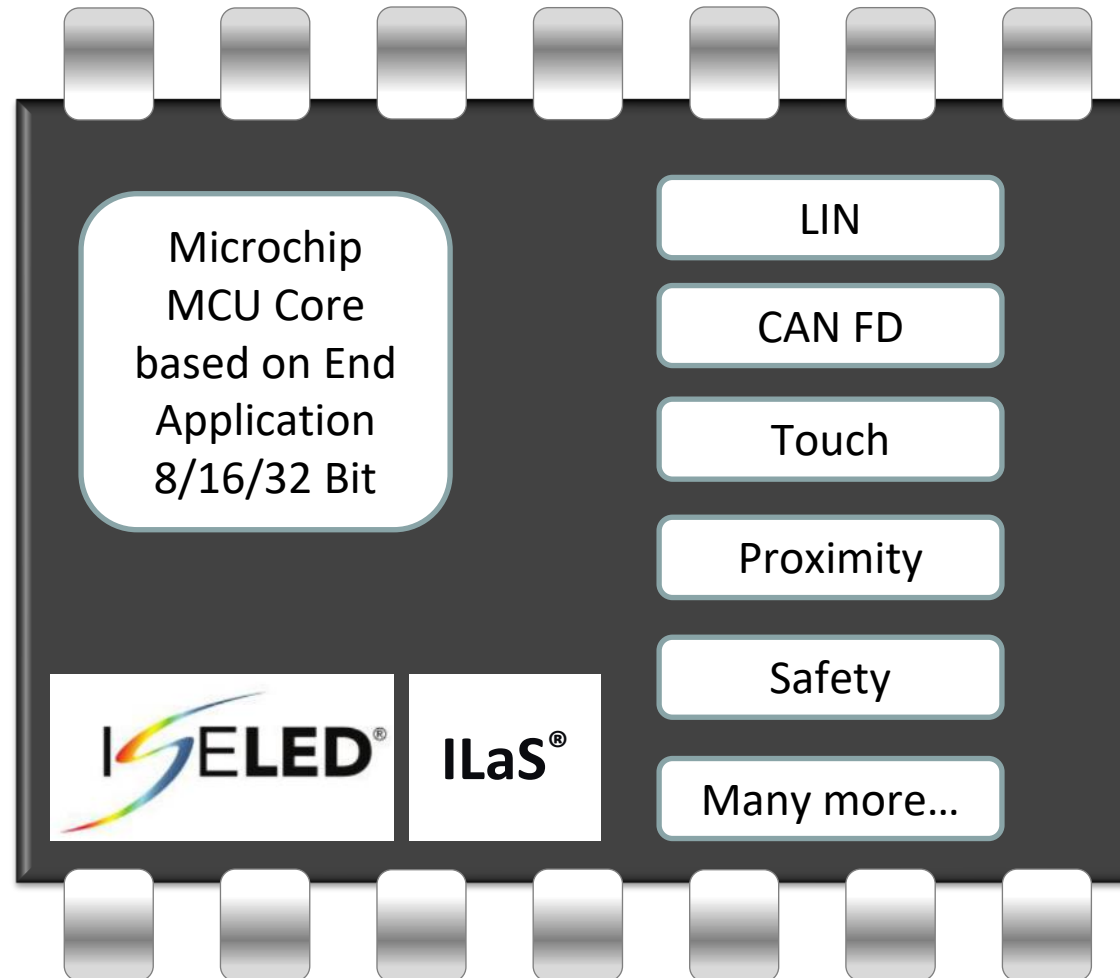

Supported ISELED®/ILaS® Devices

8-bit Microcontroller

- PIC16F153xx
- PIC16F188xx
- PIC18FxxK42
- PIC18FxxK83
- PIC18FxxQ10
- PIC18FxxQ43
- AVR128DA64

16-bit Microcontroller

- PIC24FJxxxGA70x
- dsPIC33EP128GS706
- dsPIC33EV256GM106
- dsPIC33EV256GM102

32-bit Microcontroller

- ATSAMHA1*
- ATSAMDA1
- ATSAMD21
- ATSAMC21
- ATSAM5x
- ATSAME5x

www.microchip.com/iseled



32-bit MCU Automotive Portfolio

ISELED[®] Support (Interior Lighting) Automotive Qualified Released

ISELED APPLICATIONS



SAMD21, LIN/PTC
Cortex-M0+, 45 DMIPS
32-256KB/4-32KB

AEC-Q100
Grade 1

SAMC2x(N) (5V), CAN/PTC
Cortex-M0+, 45 DMIPS
32-256KB/4- 32KB

AEC-Q100
Grade 1

Entry Level
32-bit MCU

SAMD5x/SAME5x
Cortex-M4F 150 DMIPS
256KB-1MB/128KB-256KB

AEC-Q100
Grade 1

Mid-Range Performance 32-bit MCU

In Production

Notes:

- 1) The ISELED will be specific part numbers with a "510" part number suffix. Please refer to the datasheet for the available part numbers. No VAO or Vxx is needed since these are released as QS=YES.
- 2) The ISELED stack will be supported by IAR and MPLAB as a separate stack.

Microchip ISELED[®] Recommendation (CAN Interface)

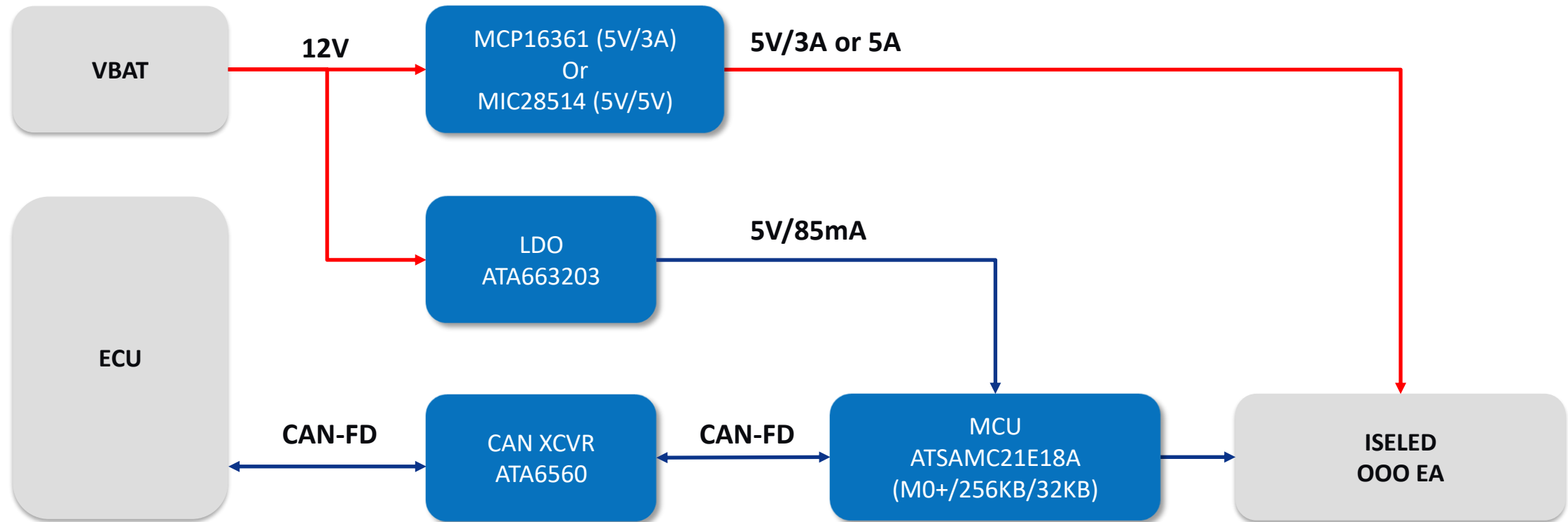

[MCP16361](#) (Input 4V~48V, Output 2.0V~24V/3A)

[MIC28514](#) (Input 4.5V~75V, Output 0.6V~32V/5A)

Microchip ISELED[®] Recommendation (LIN Interface)

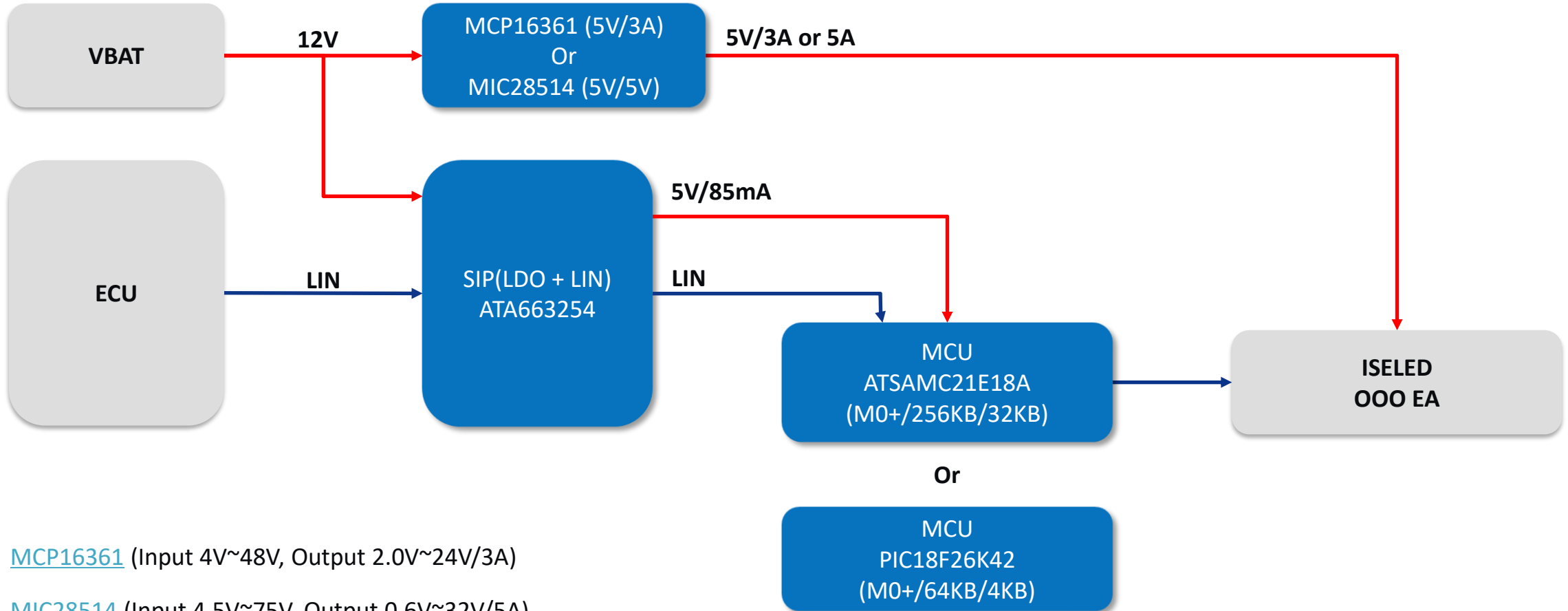

[MCP16361](#) (Input 4V~48V, Output 2.0V~24V/3A)

[MIC28514](#) (Input 4.5V~75V, Output 0.6V~32V/5A)

ILaS[®] – ISELED[®] via Cables/Distance

ILaS – ISELED Light and Sensor Network



Bild 2: Der ILaS-Busknotten im Zusammenspiel.

(© Inova Semiconductors)

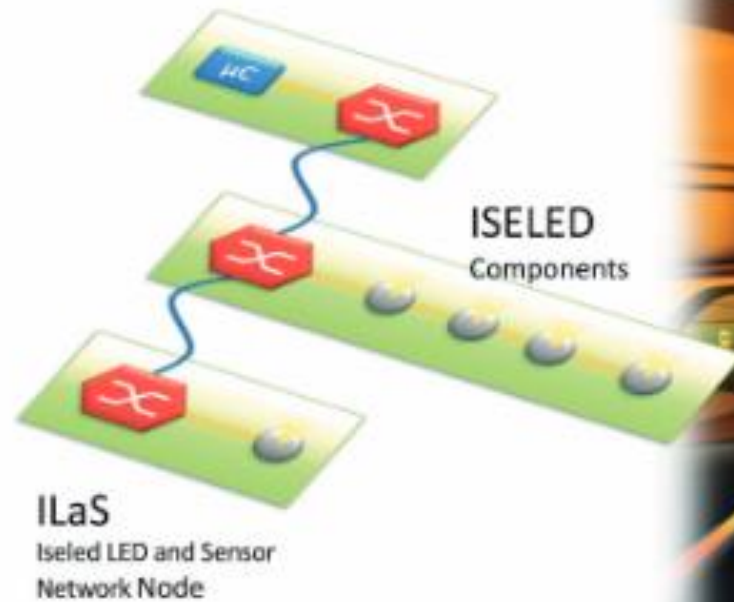

ILaS[®] with Touch & Proximity Solution

System Block Overview

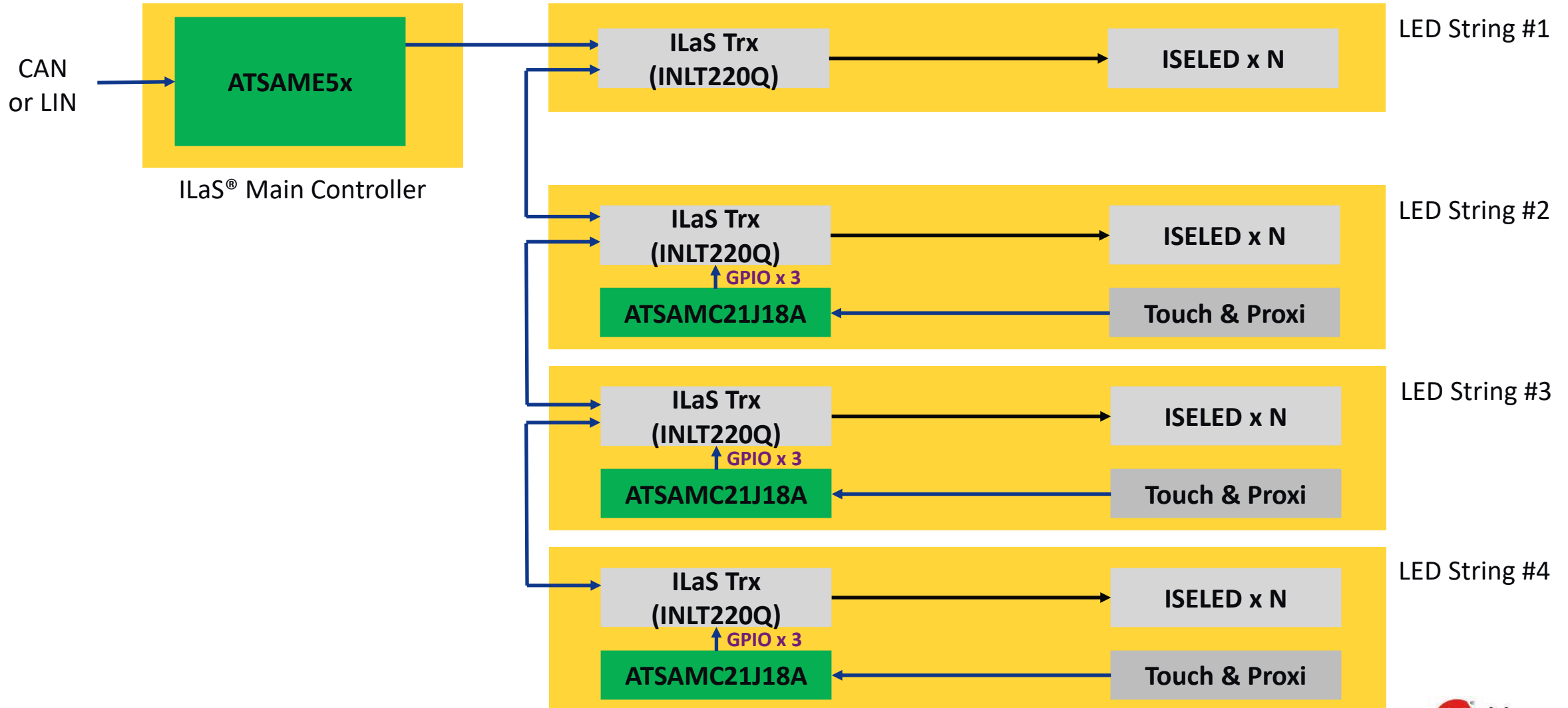

TSS Example ILaS[®]

Bringing Innovation Together

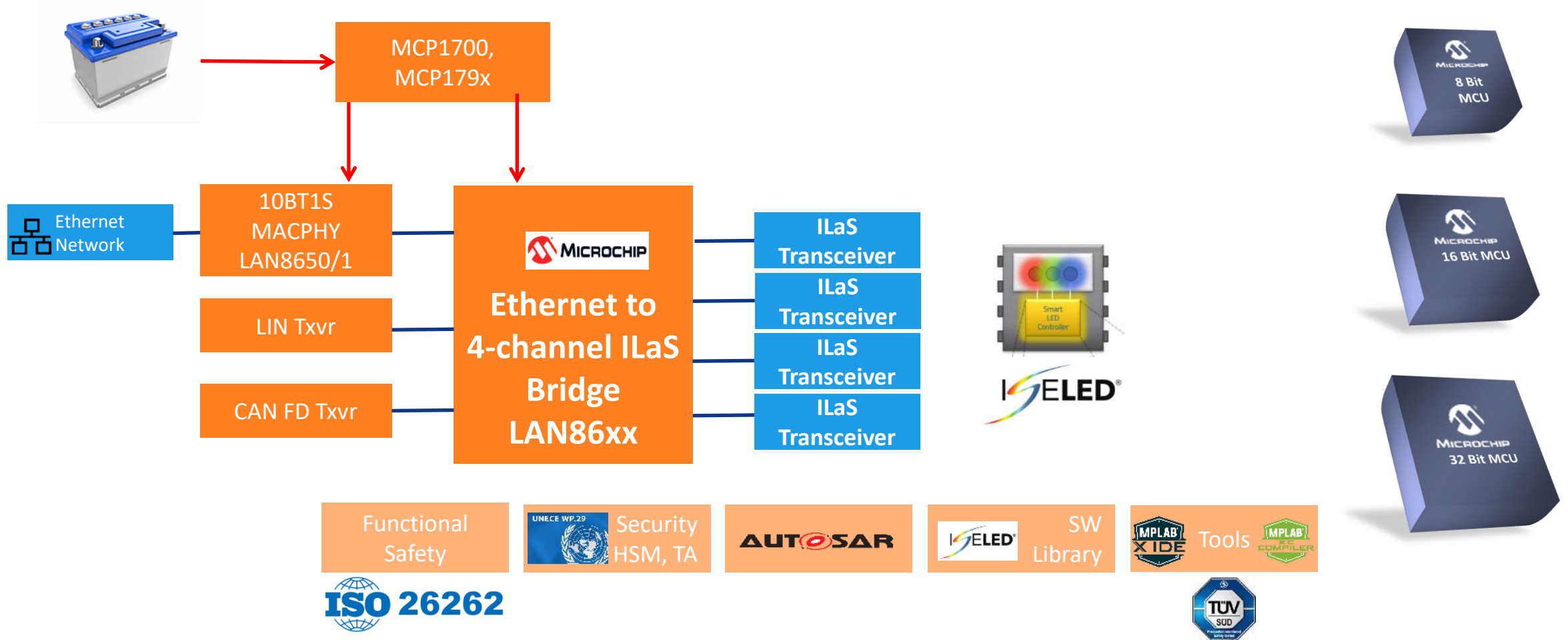

ISELED® Design Guide – Korean

ISELED Design Guide 

한국 마이크로칩 테크놀로지

ISELED Design Guide

A01-2022.6.24 Microchip Korea 1

ISELED Design Guide 

Contents

- Revision History 5
- 1. ISELED 솔루션 소개 6
- 2. ISELED 라이브러리 지원 마이크로컨트롤러 6
 - 2.1. ISELED 지원 마이크로 컨트롤러 리스트 7
- 3. 기술자료 제공을 위한 NDA 절차 7
- 4. 하드웨어 디자인 가이드 7
 - 4.1. 하드웨어의 구성 개요 7
 - 4.2. 마이크로컨트롤러(MCU)와 첫번째 ISELED 사이 통신 8
 - 4.3. 파워 서플라이 디자인 8
 - 4.4. 마이크로컨트롤러 클럭 설정 8
- 5. 소프트웨어 디자인 가이드 9
 - 5.1. Evaluation version ISELED stack 9
 - 5.2. Full licensed version ISELED stack 10
 - 5.3. Evaluation vs Full licensed version ISELED stack 비교 10
 - 5.4. ISELED 라이브러리 용량 11
 - 5.5. ISELED API Document 11
 - 5.6. ISELED 2 채널 동작 구성방법 11
 - 5.7. ISELED 제어 개수 설정 11
 - 5.8. 통신 포트 설정(ATSAMC21) 11
 - 5.9. ISELED 통신 구현을 위한 MCU 주변장치(SPI, DMA, Timer) 12
- 6. Production License 12
- 7. ISELED Specification 14
 - 7.1. ISELED 특징 14
 - 7.2. ISELED 최대 전류 14

A01-2022.6.24 Microchip Korea 3

ISELED Design Guide 

- 8. 개발보드, 데모 및 참고문서 15
 - 8.1. 32 비트 MCU 솔루션(ATSAMC21J18A) 15
 - 8.3. 300EA ISELED 데모 15
 - 8.4. Battery Charging door 16
 - 8.5. ISELED Easy Evaluation Board 16
 - 8.6. 참고문서 16
 - 8.6.1. ISELED API Document 16
 - 8.6.2. ISELED Datasheet(Dominant) 16

A01-2022.6.24 Microchip Korea 4

ISELED® Easy Evaluation Board Project

Easy Evaluation Board Preview

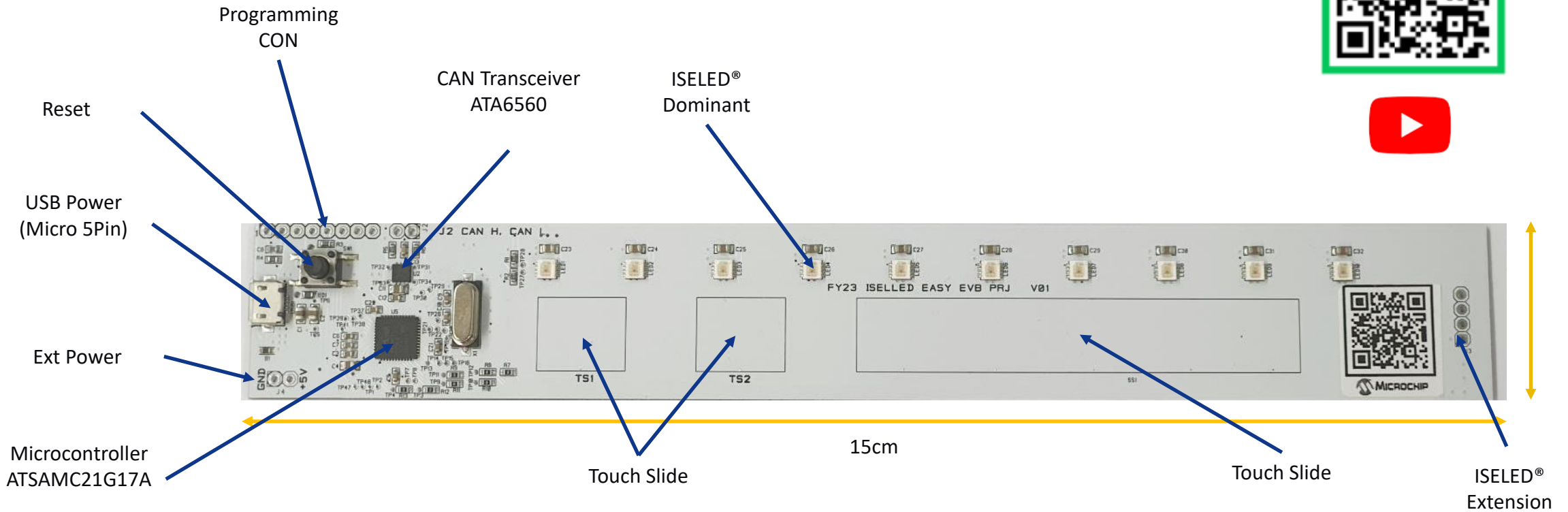

[Easy Evaluation Board Circuit Diagram](#)

[seddLED3.0 A3A-FKG Datasheet](#)

Demo

YouTube

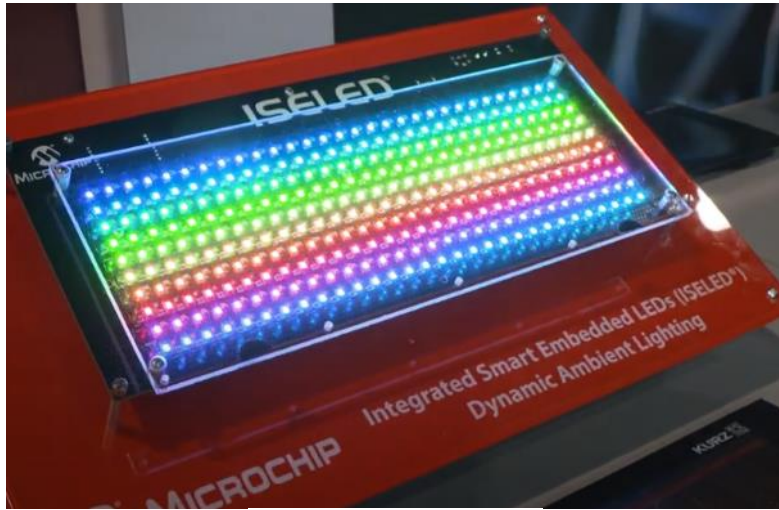

Summary

- **Enabling Innovation**
 - Low system costs & low investment costs
- **ISELED[®] Value Added Solutions**
 - Highly integrated functions on micro and system level
- **Widest Automotive Micro Portfolio**
 - Solutions from 8-bit to 32-bit microcontrollers
 - Low risk, low cost, fast time-to-market development



Contact

마이크로칩 기술부
신기원 책임

Kenny.Shin@microchip.com

감사합니다
