

Consumer & Automotive Market을 위한 ICLED 솔루션



A Leading Provider of Smart, Connected and Secure Embedded Control Solutions



SMART | CONNECTED | SECURE

Presented by
Kenny Shin, Senior Embedded Solutions Engineer
November 21, 2024

LED Lighting



What are LEDs?

LEDs

- **Light-Emitting Diodes** – they operate off DC current, flowing in one direction
- **Low-voltage (~3.2 volts), non-linear, current-controlled devices**
- **They can be five times the efficacy of incandescent lamps**
- **LEDs get hot, cooling required**
- **LEDs can be ten times the reliability of an incandescent, BUT only if they are kept to an acceptable operating temperature**

LEDs

- Typical electrical symbol

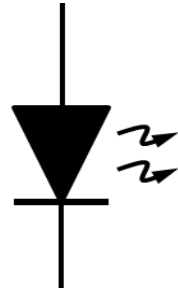

- Typical LED



Quiz - Question

- **Why do white LEDs look yellow when they are off?**



Quiz - Answer

- **Additive color mixing: when you take blue from white, you will get yellow**

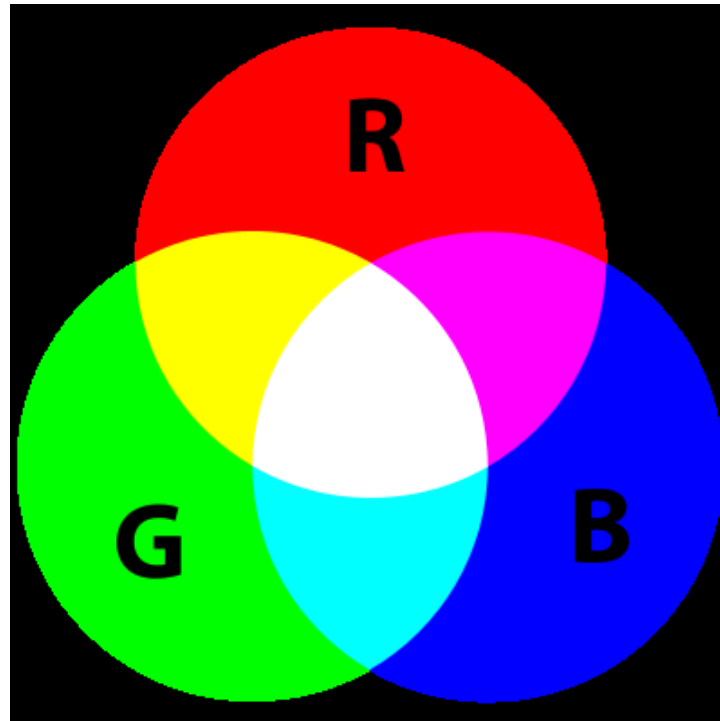

Vocabulary

- **LUMENS**

- The apparent (human eye perception) total amount (add up from all directions) of light from a lamp.

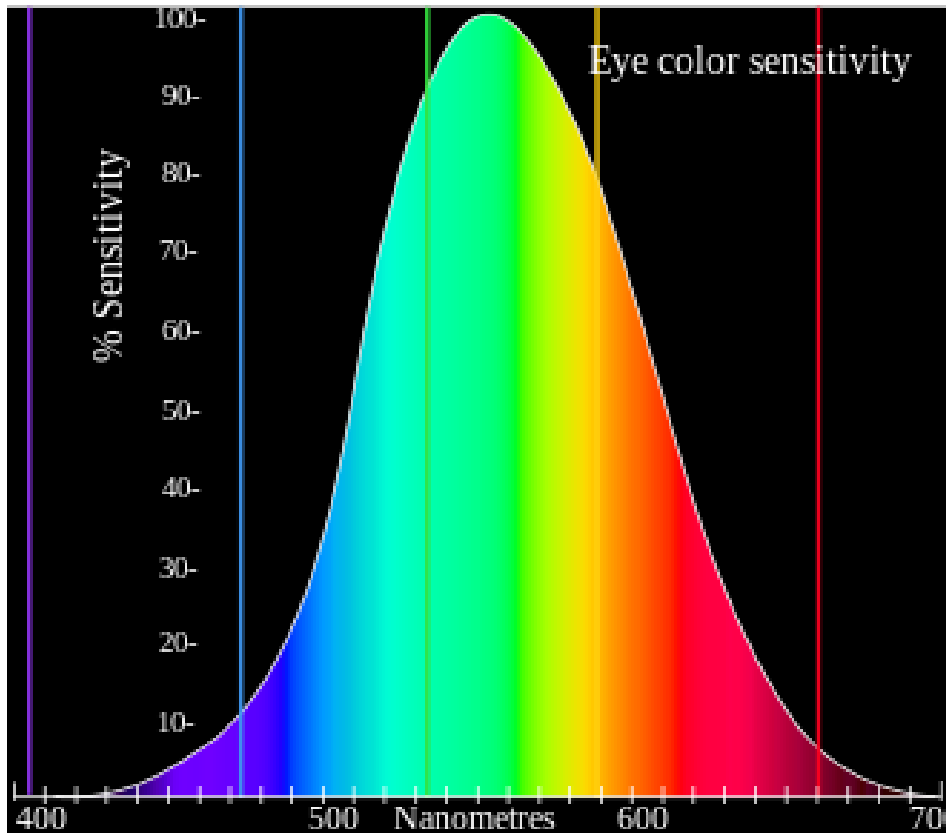

The human eye can see from about 400 nm wavelength (violet) to 700 nm (red), with **peak sensitivity at green (~555 nm)**

Quiz - Question

- **You are building a greenhouse in Colorado to grow herbs indoors with artificial light. Are you significantly concerned about the lumen output and efficacy of your lamps?**

Quiz - Answer

- **No. Plants are green because they are reflecting green light to your eyes. Giving plants green light is a waste of energy. A handy reminder: “Lumens are for humans”.**

Quiz - Question

- In your “lighting optimized” greenhouse, what would be the theoretical color your plants would look like?

Quiz - Answer

- **Black.**
 - Your plants should absorb all the light you shine on them. Not a real scenario. But, sometimes, our eyes aren't the right tool for evaluating a lighting application.

LED Basic

LED Basic

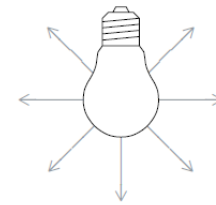

Forward Current^{2) page 18}

$$I_F = f(V_F); T_S = 25\text{ }^\circ\text{C}$$

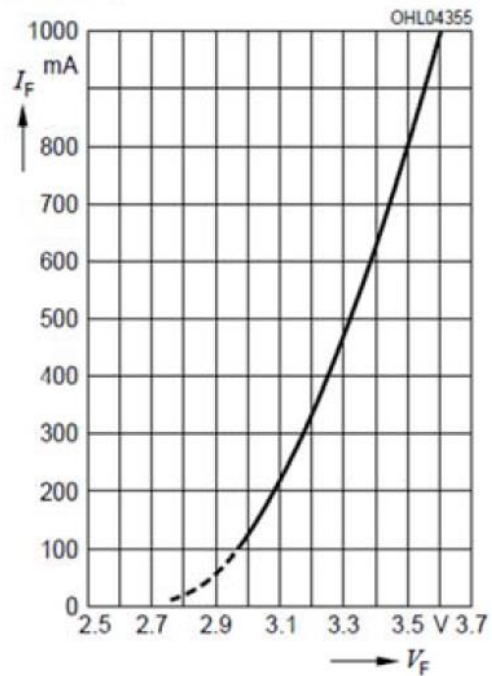

Relative Forward Voltage^{2)4) page 17}

$$\Delta V_F = V_F - V_F(25\text{ }^\circ\text{C}) = f(T_j); I_F = 350\text{ mA}$$

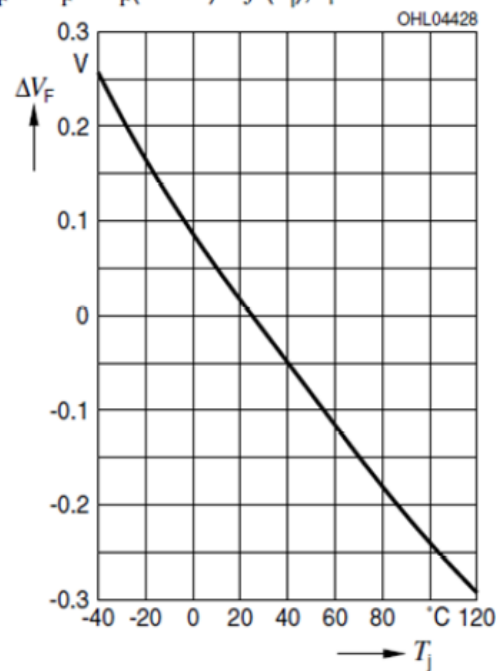

Relative Luminous Flux^{2) 5) page 18}

$$\Phi_V / \Phi_V(350\text{ mA}) = f(I_F); T_S = 25\text{ }^\circ\text{C}$$

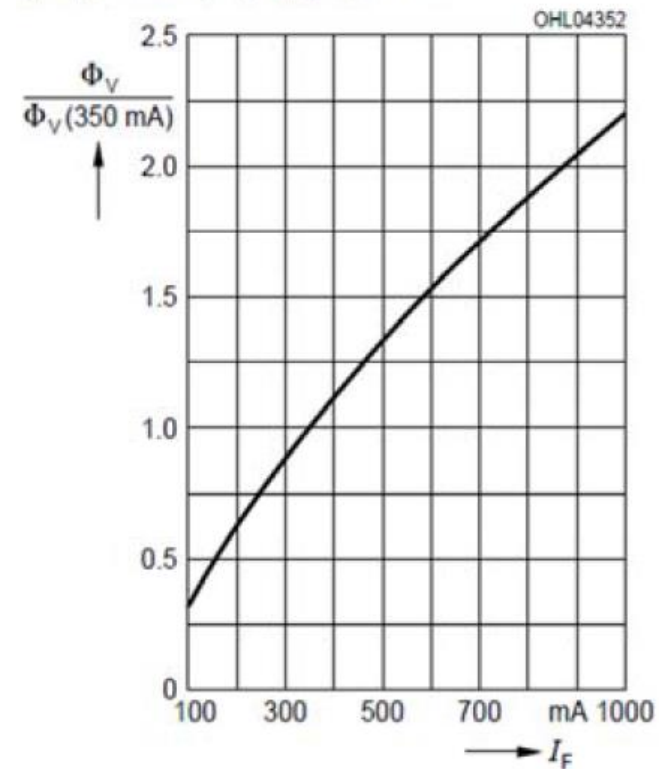

Luminous Flux (Lichtstrom) Lumen, lm, cd/sr

LED Basic

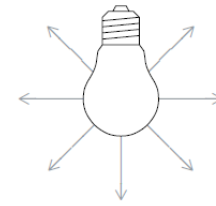

Chromaticity Coordinate Shift²⁾ Seite 18

$x, y = f(I_F); T_S = 25\text{ °C}$

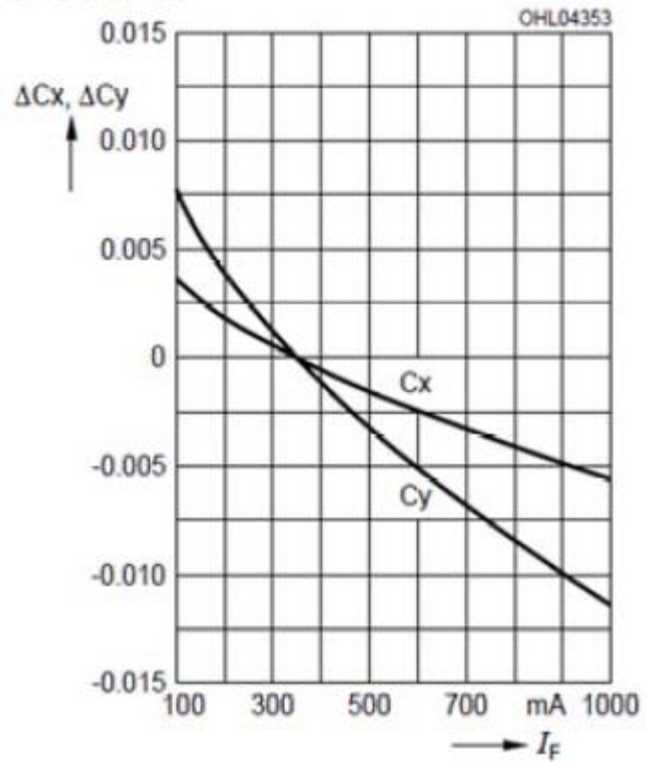

Chromaticity Coordinate Shift²⁾ page 20

$x, y = f(T_j); I_F = 350\text{ mA}$

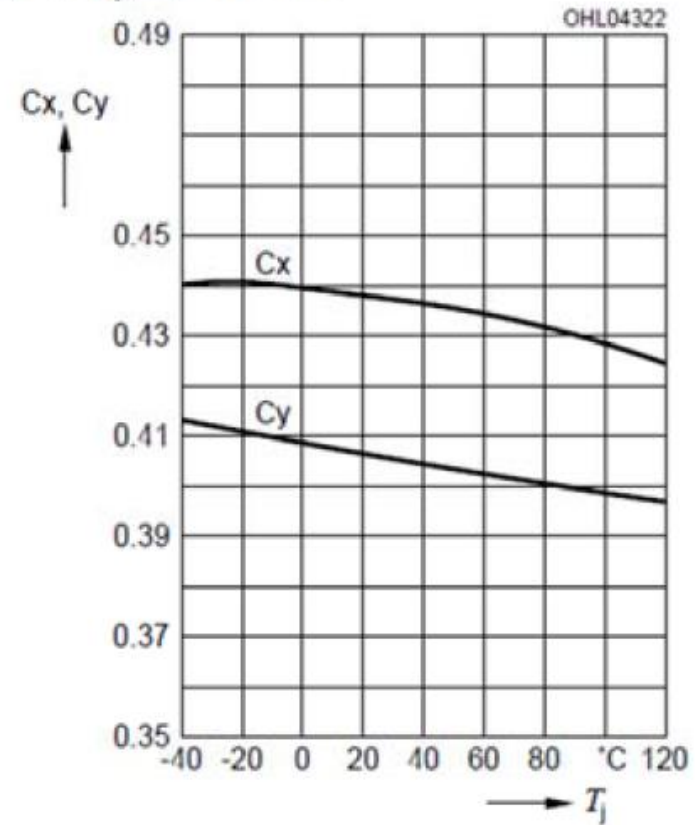

Detection of Single Shorted LEDs

- Detection of short circuits against Ground, V_{bat} and Phase against Phase (multi-string drivers)

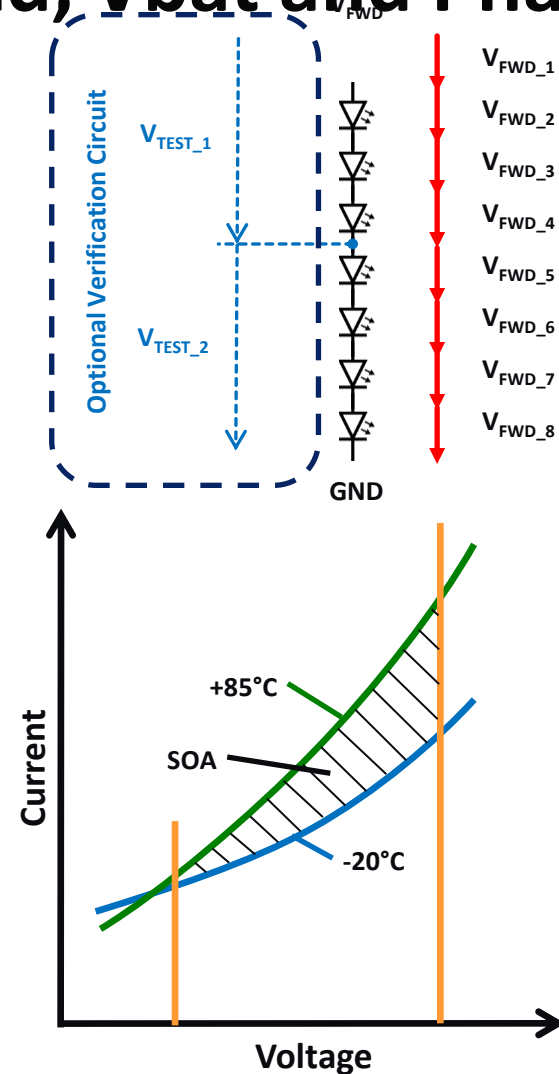

LED Dimming

LED Dimming

- **Dimming Methods**

- Analog/Linear Dimming, Constant Current Reduction
- PWM Dimming
- PWM(Pulse Width Modulation) dimming is actually turning the LED current on and off for a short period of time

LED Dimming

Forward Current⁽²⁾ page 18

$$I_F = f(V_F); T_S = 25^\circ\text{C}$$

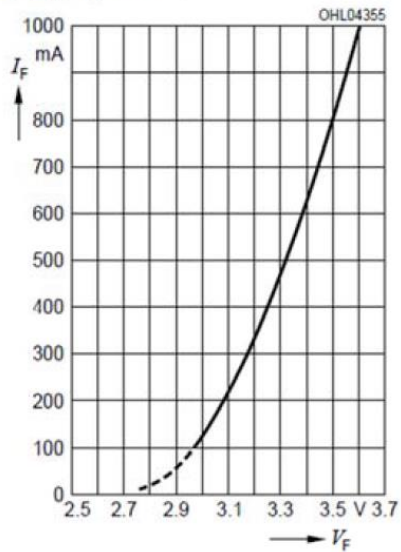

Chromaticity Coordinate Shift⁽²⁾ Seite 18

$$x, y = f(I_F); T_S = 25^\circ\text{C}$$

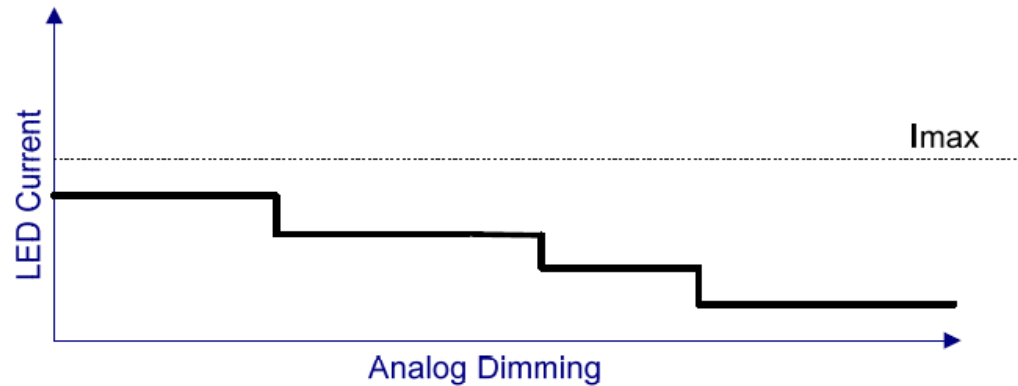
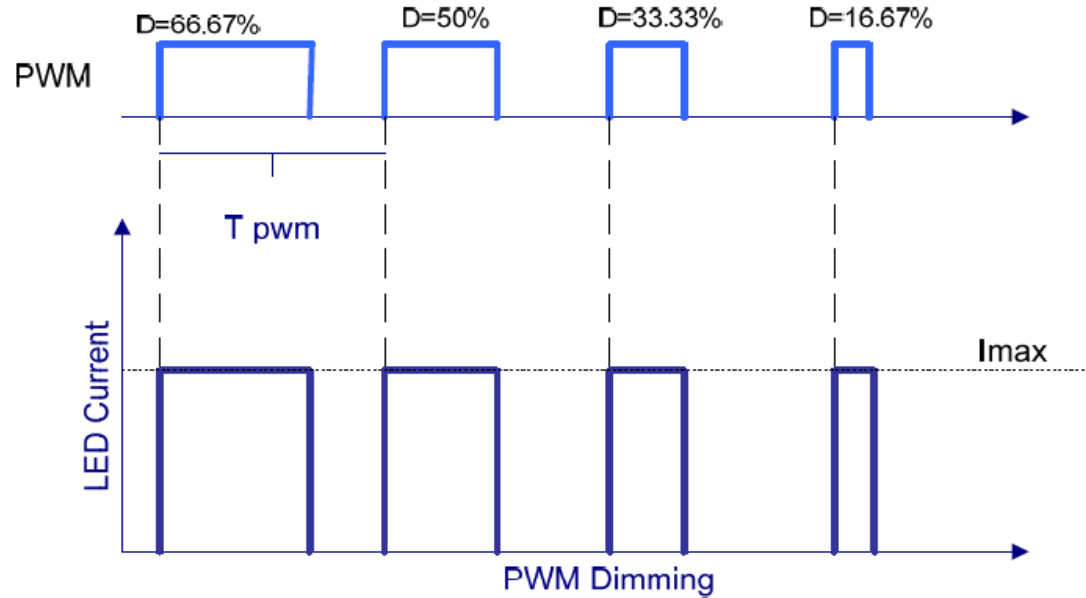
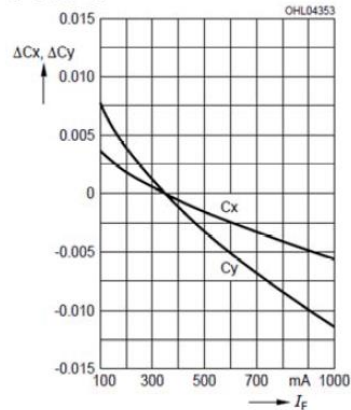

LED Dimming Comparison

PWM Dimming	Analog Dimming
Brightness adjusted by modulating the peak current in the driver	Brightness adjusted by changing the DC current going to the LED
No color shift	Possible color shift as LED current changes
Possible current inrush problems	No inrush current to device
Frequency limitations & possible frequency concerns	No frequency concerns
Very linear change in brightness	Brightness linearity not as good
Lower optical to electrical efficiency	Higher optical to electrical efficiency (>lumens per watt consumed)

ISLED[®] for Automotive

Smart Ambient LED Lighting



ISELED® Alliance

ISELED ALLIANCE MEMBERS



Legacy vs. ISELED®

Legacy RGB LED Lighting

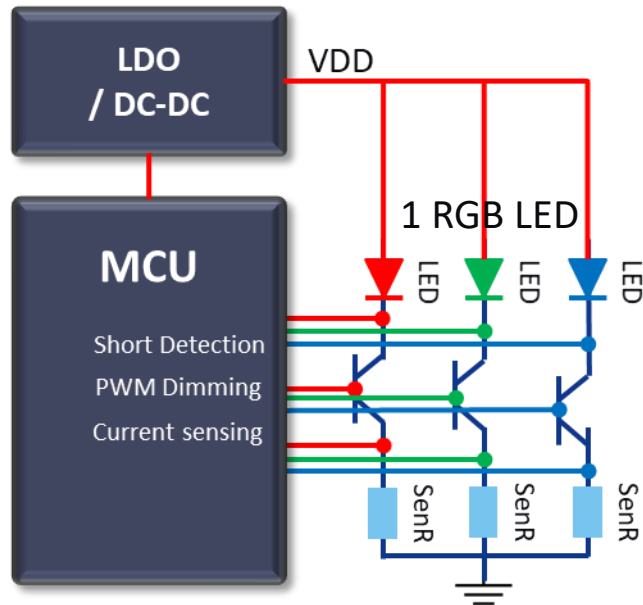

Controller requires at least 9 ports for 1 RGB LED control

ISELED RGB LED Lighting

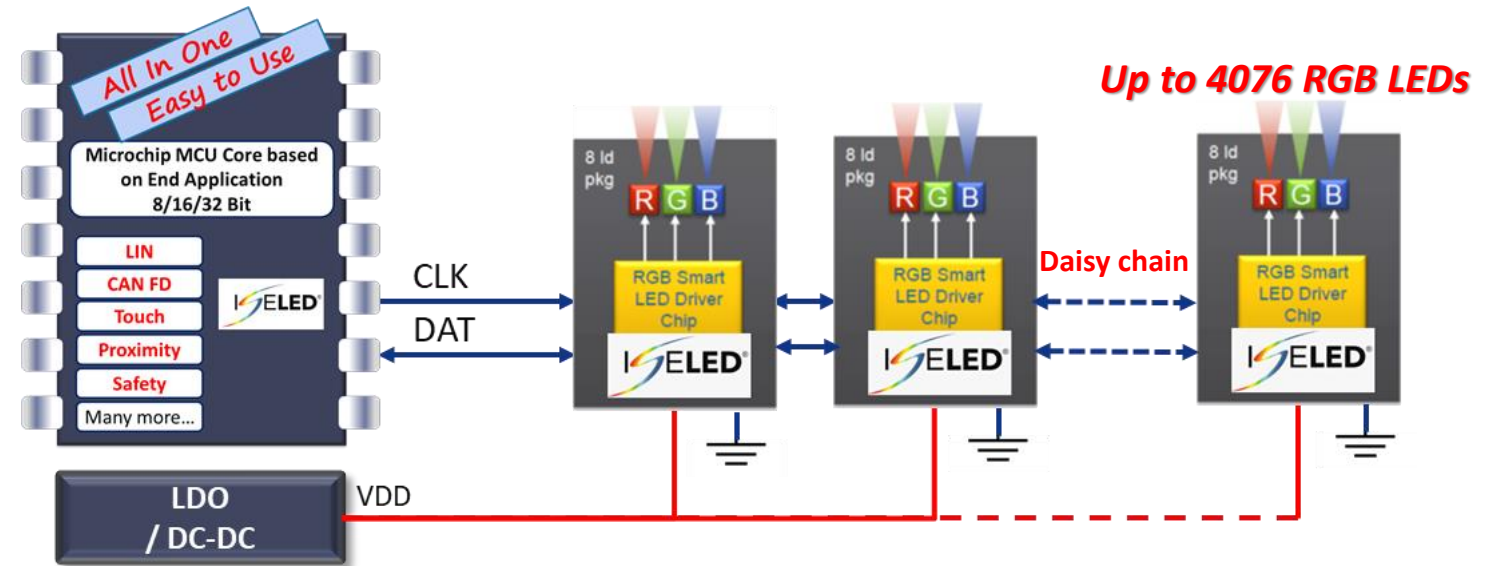

2 ports are sufficient for RGB LED control/Simple Layout/Components Reduction

ISELED® Control with Microchip Microcontroller

What is ISELED Control?

- It is a combination of three LED chips (red, green, blue) and an ASIC which controls the LEDs plus doing the communication in one package
- Binning and calibrated RGB LEDs
- Increases speed for enabling dynamic Light effects
- The ISELEDs are connected in series as a LED chain

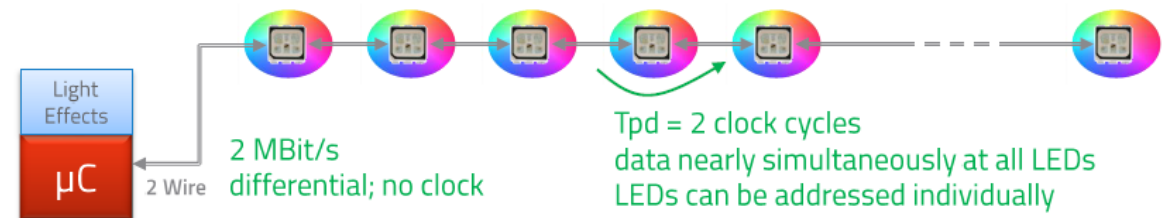
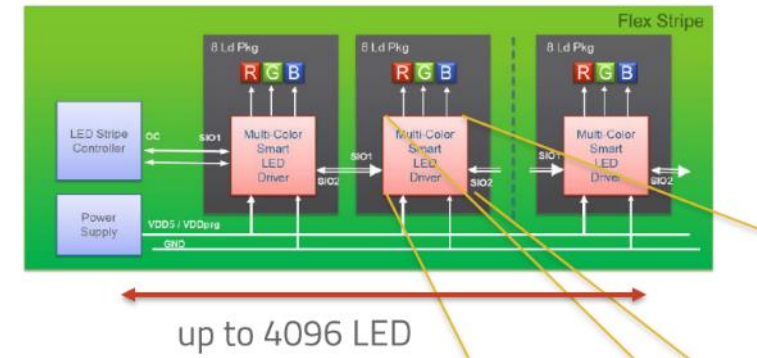
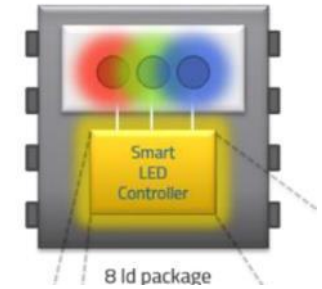

ISELED® Solution

Advantages

- Uses only FOUR wires (DAT, CLK, 5V, GND)
- Digitally addressable
- Smart RGB LED modules with integrated smart LED driver
- Serial daisy-chain bus (*Up to 2 Mbps)
- Up to 4079 ISELED connections
- LED Open/Short Detection
- Factory calibration for color
- Temperature compensation automatically

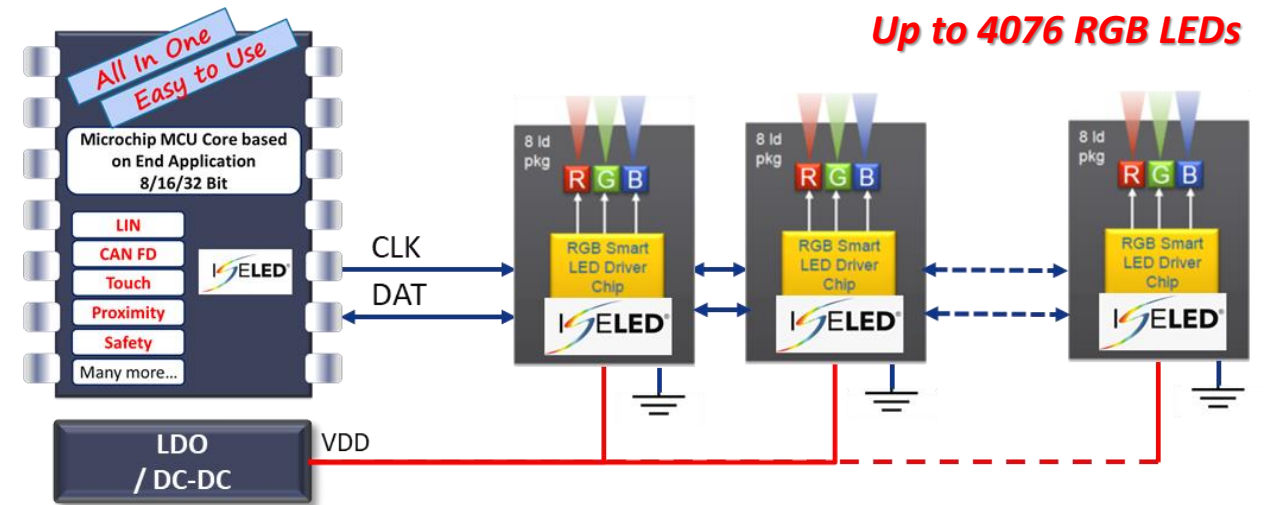

*Updating every single LED in a chain with 100 LEDs is performed in 5.25 ms, allowing frame rates of over 100Hz.

ISELED[®] Hardware Connection

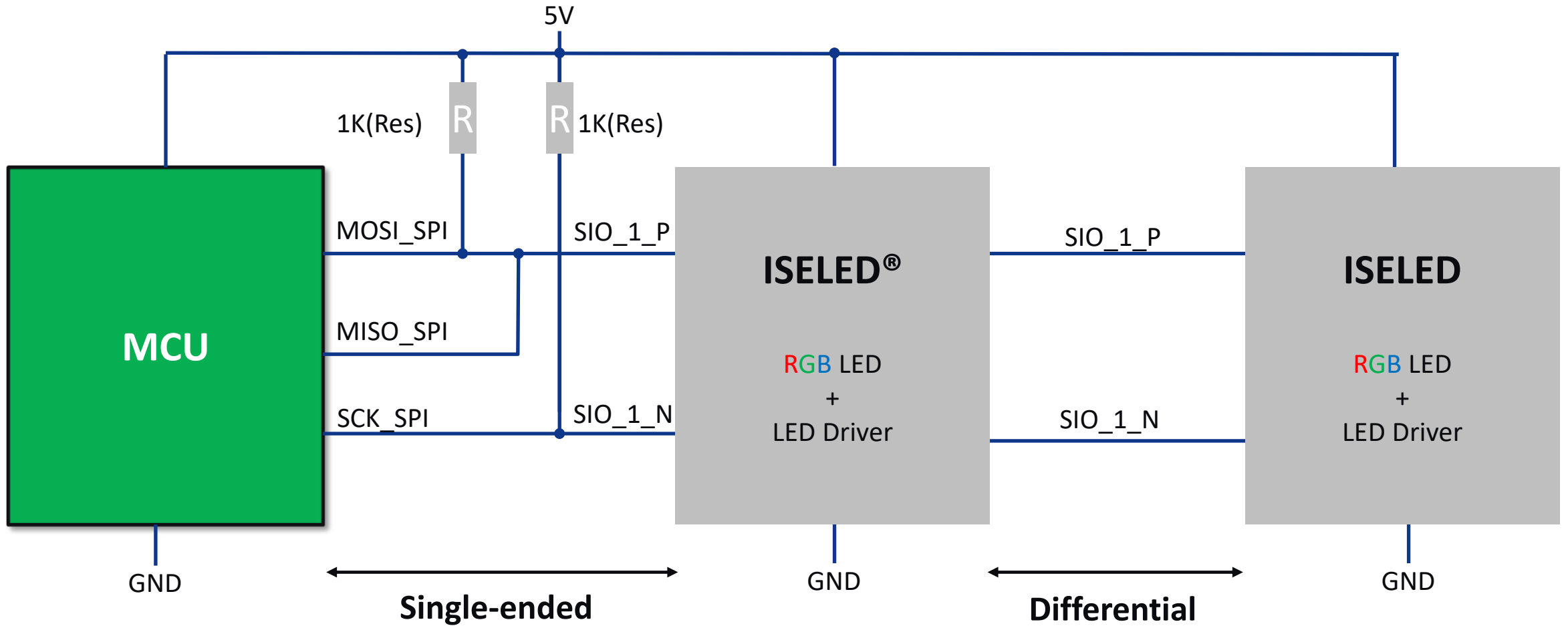

*Length: Max 15cm

*Depend on capacitance and resistance

ISELED[®] Application



Suited based on End Application

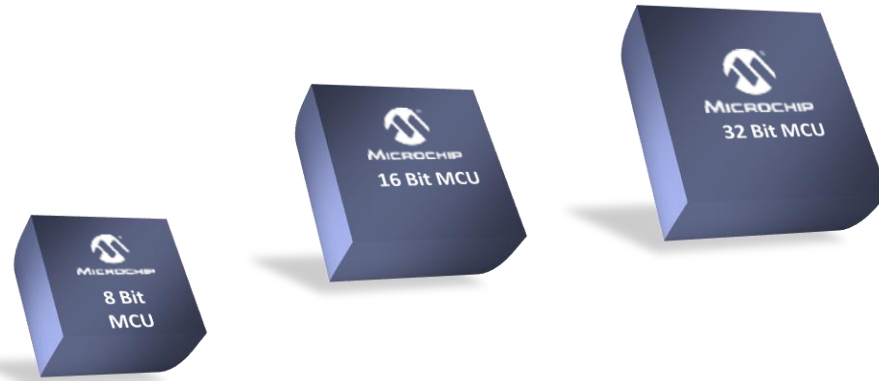

Lowest Power

Highest Performance

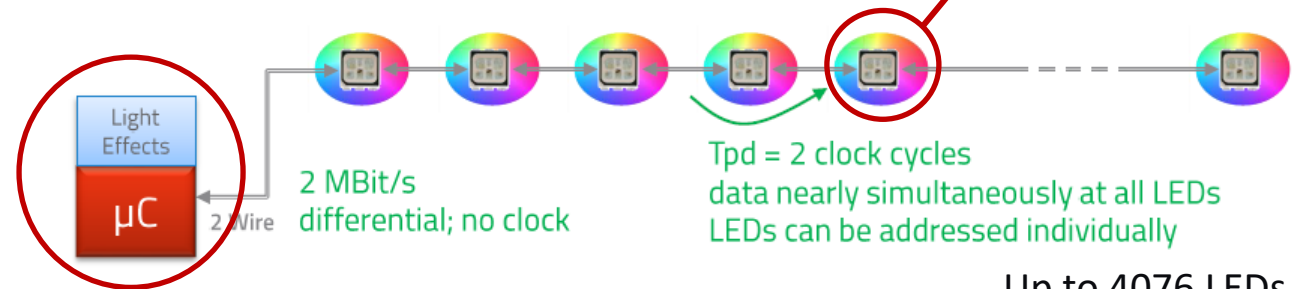
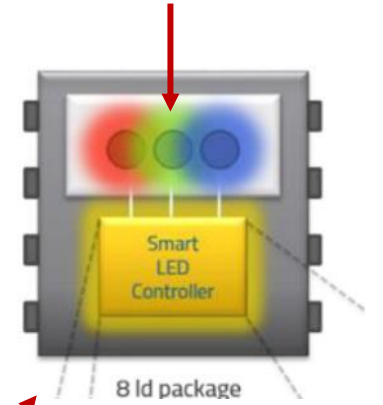

Up to 4076 LEDs

ISELED[®] Core Independence

All-in-one

Easy-to-use

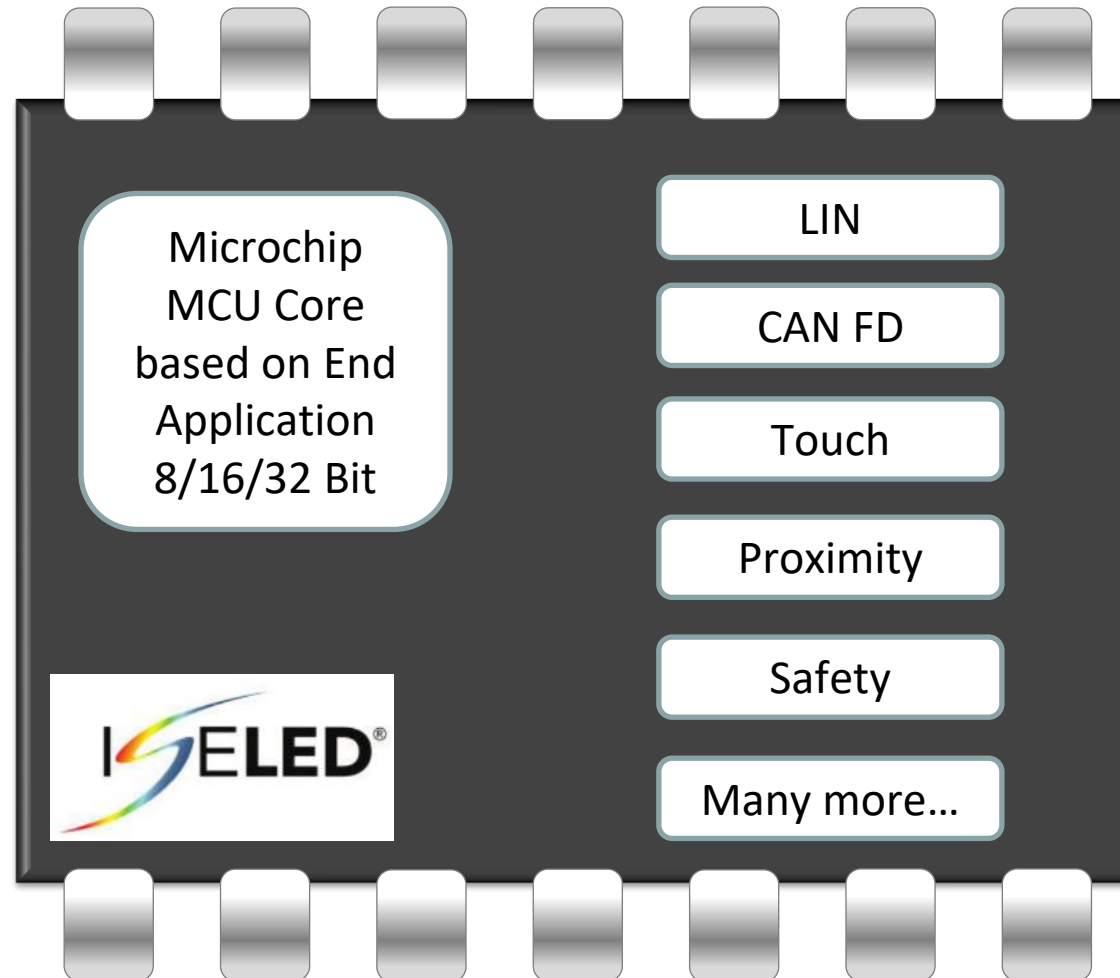

ICLED for Automotive

What is ICLED?

RGB + IC Application

- Smart Speaker
- ARGB (Addressable)
- Gaming Monitor
- Gaming Keyboard
- Gaming Mouse
- Case
- Motherboard
- Fan
- Gaming GPU
- Gaming RAM
- Transparent Display
- Interior Lighting

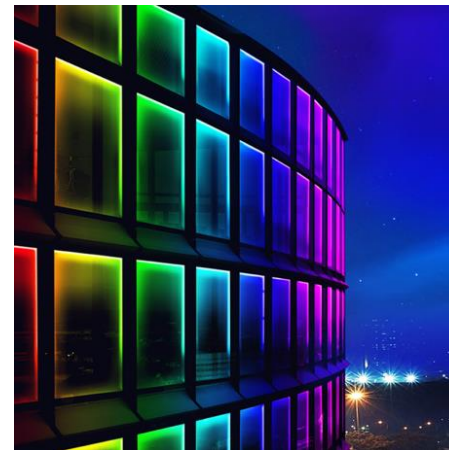

What is ICLED?

RGB + IC Advantage

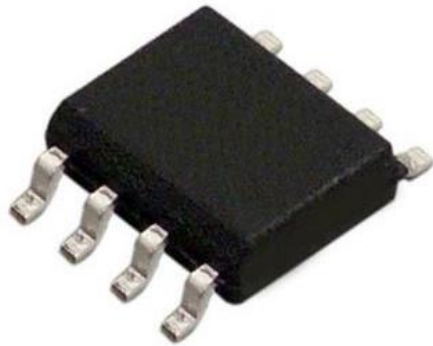

LED Driver IC



RGB LED

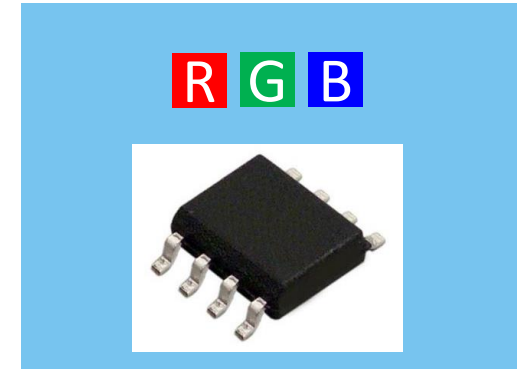

IC LED

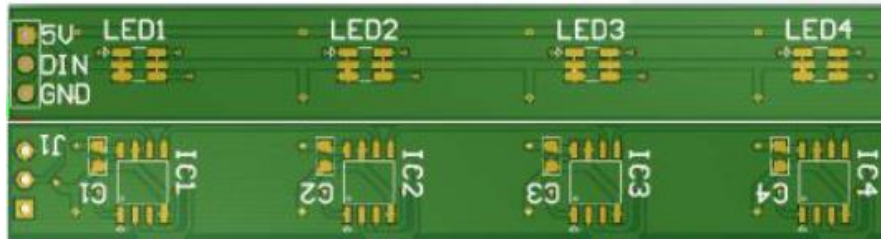

- Simplified Layout
- Reduced the BOM parts
- Reduced the SMT count, Lower the manufactured cost

What is ICLED?

RGB + IC Extended Functionality

- **Breakpoint resume**
 - Significantly reduce the impact of defective LED
- **Adjustable Forward Current**
 - Adjust intensity while maintaining color gradation
- **Power Saving Mode**
 - Benefit to Bluetooth and mobile application

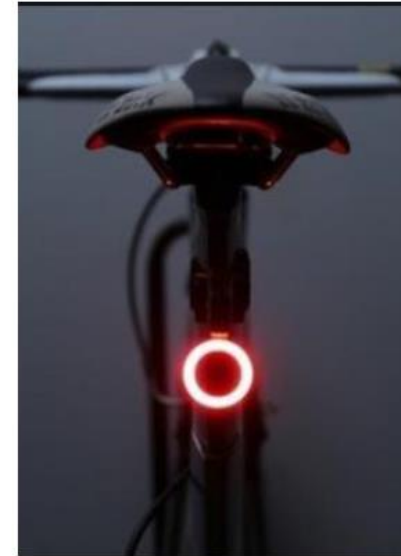
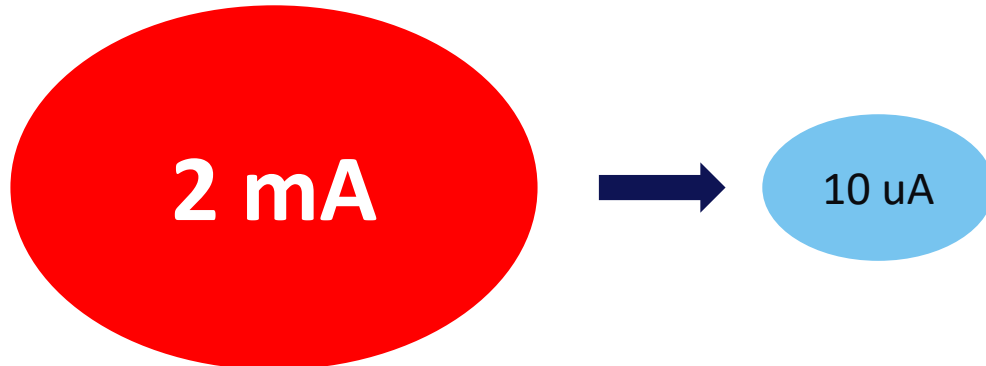

Product Advantage

Structure Advantage

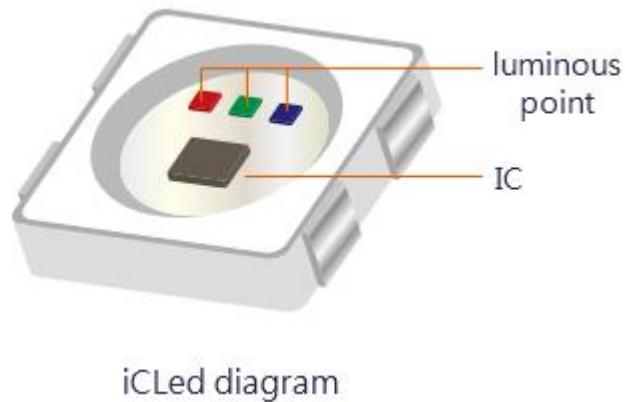

- One built-in IC
- Signal Communication
- Simplifying the circuit design

Design Advantage

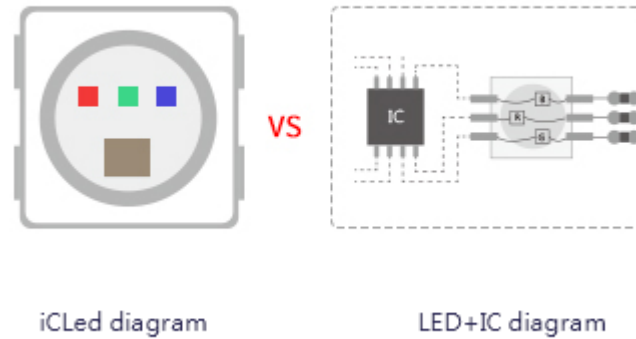

- Each ICLED has own driver IC

Color Advantage

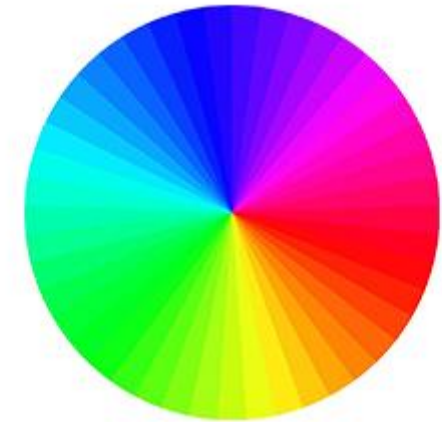

- 8bit PWM for RGB LED each
- 16,777,216 colors

ICLED Hardware Connection

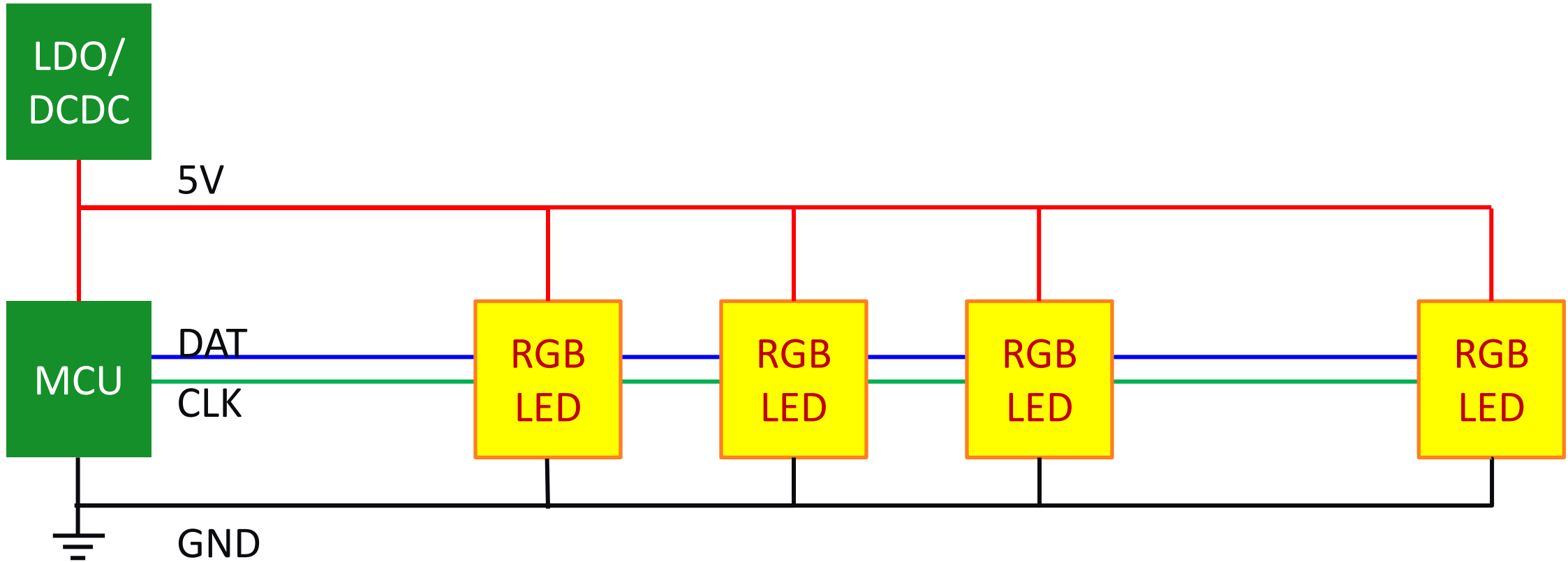

ICLED Solution

All In One

Easy to Use

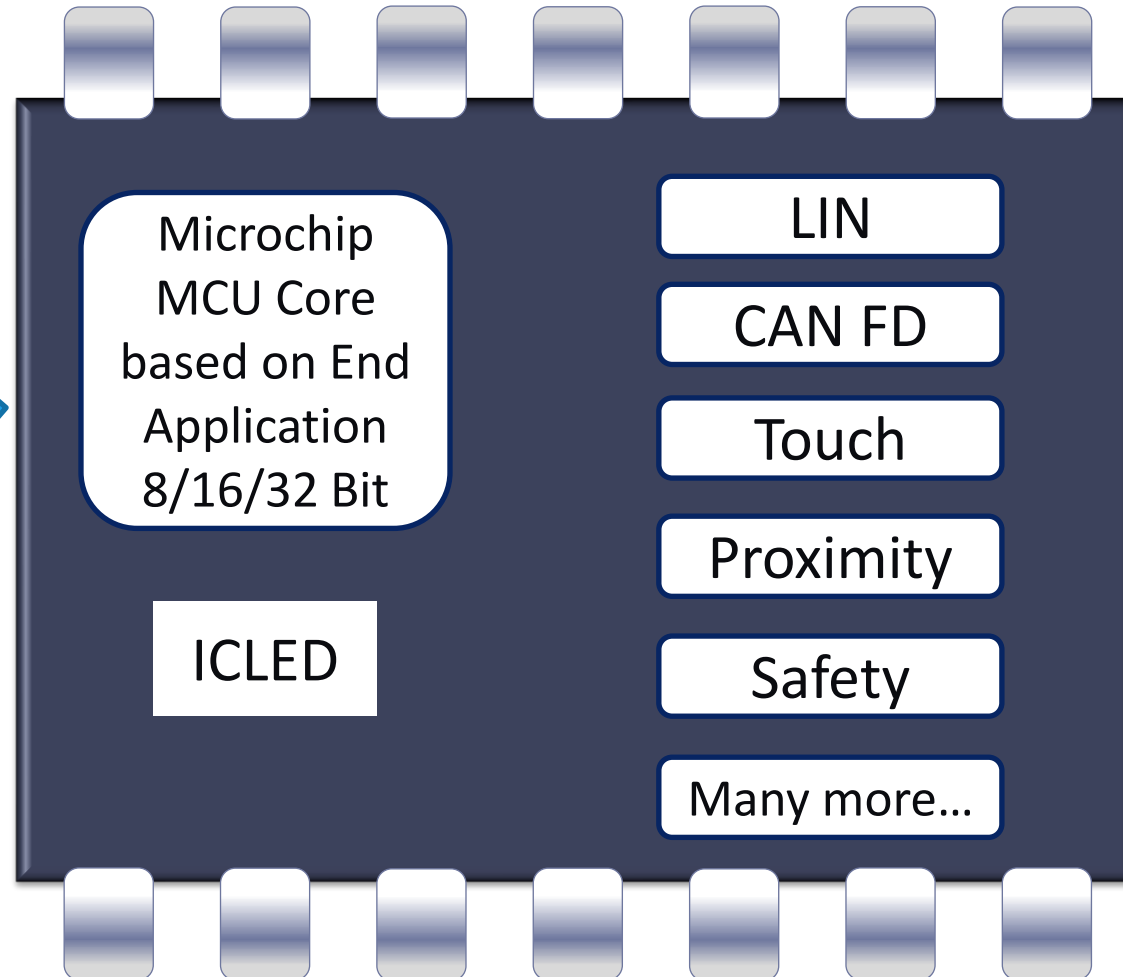

Total System Solutions

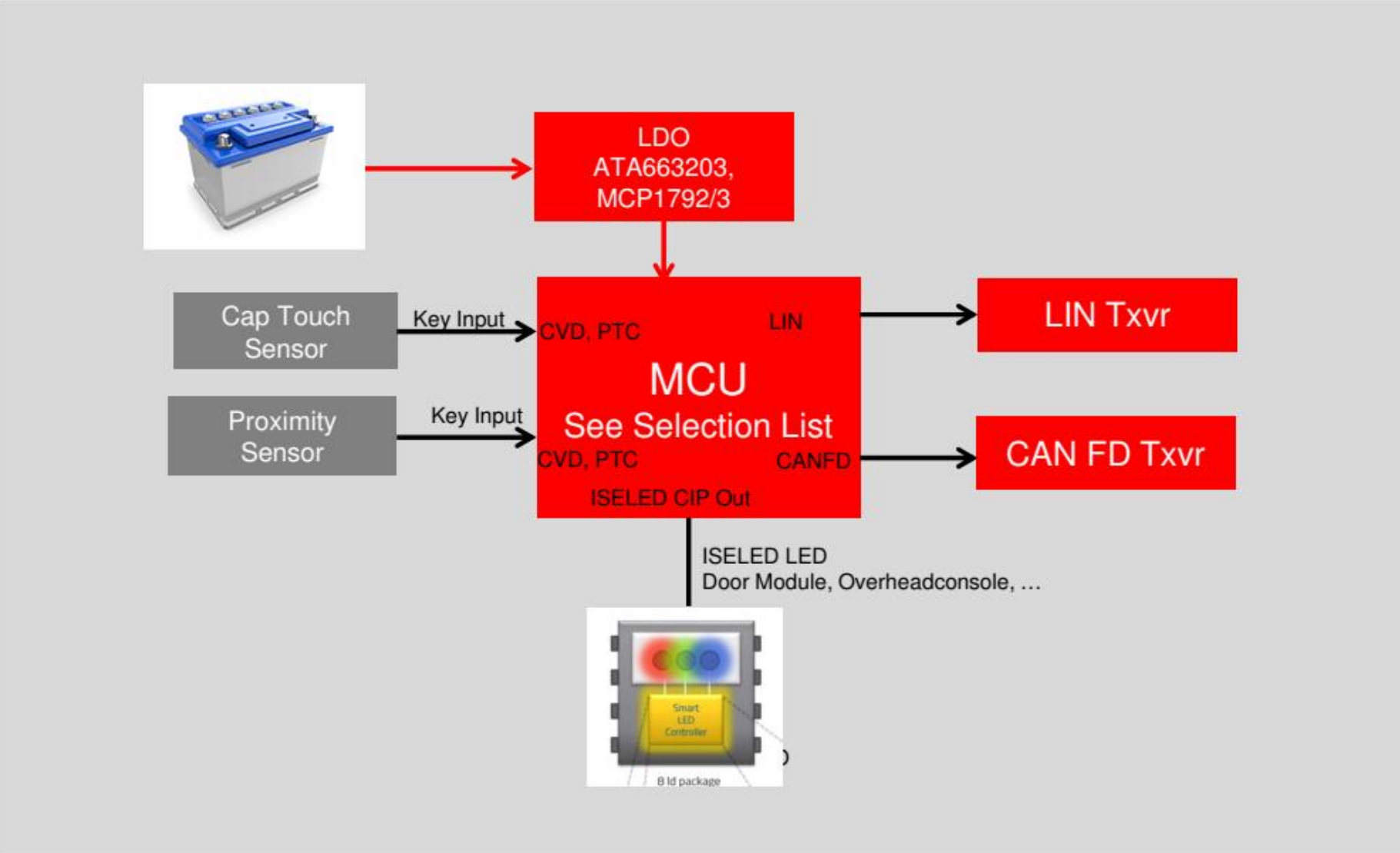

WS2812 with CLB (Configurable Logic Block)

Products

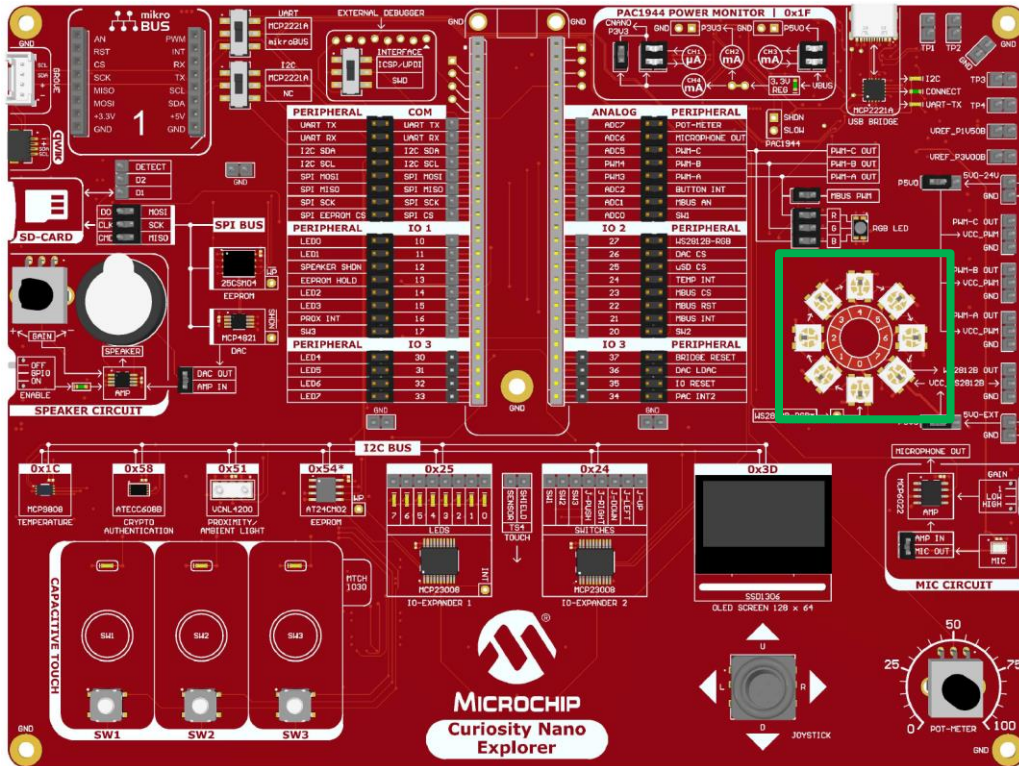

Curiosity Nano Explorer



PIC16F13145
Curiosity Nano

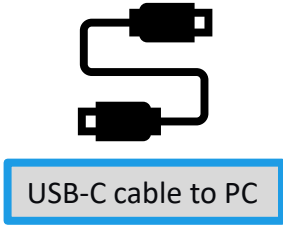

USB-C cable to PC

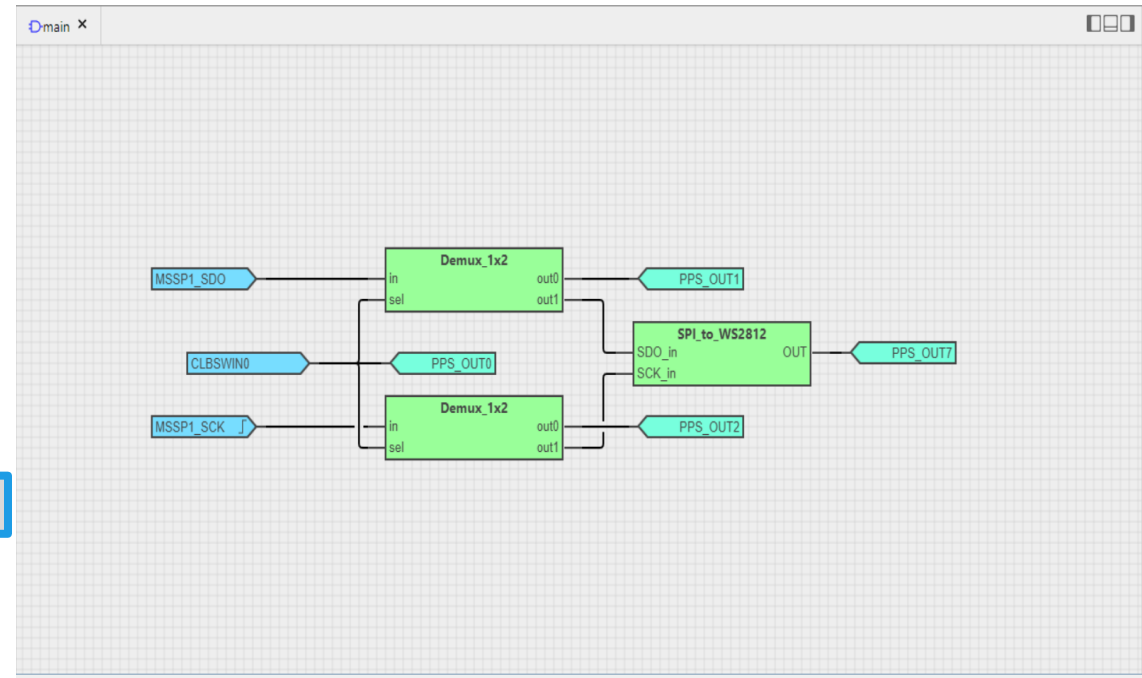

ISC3535

- Based on PIC16F18325

Data transfer time

1. Timing Wave Form

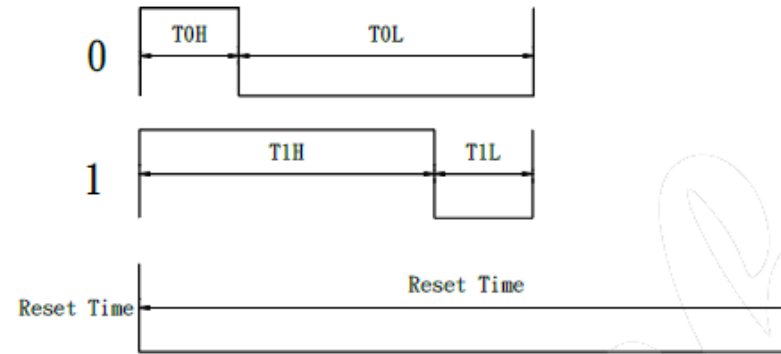

2. Data transfer time

Item	Description	Typical	Allowance
T_{0H}	0 code, high voltage time	0.3 μ s	$\pm 0.05\mu$ s
T_{0L}	0 code, low voltage time	0.9 μ s	$\pm 0.05\mu$ s
T_{1H}	1 code, high voltage time	0.9 μ s	$\pm 0.05\mu$ s
T_{1L}	1 code, low voltage time	0.3 μ s	$\pm 0.05\mu$ s
RES	reset time	>200 μ s	-

ICLED Hardware Connection

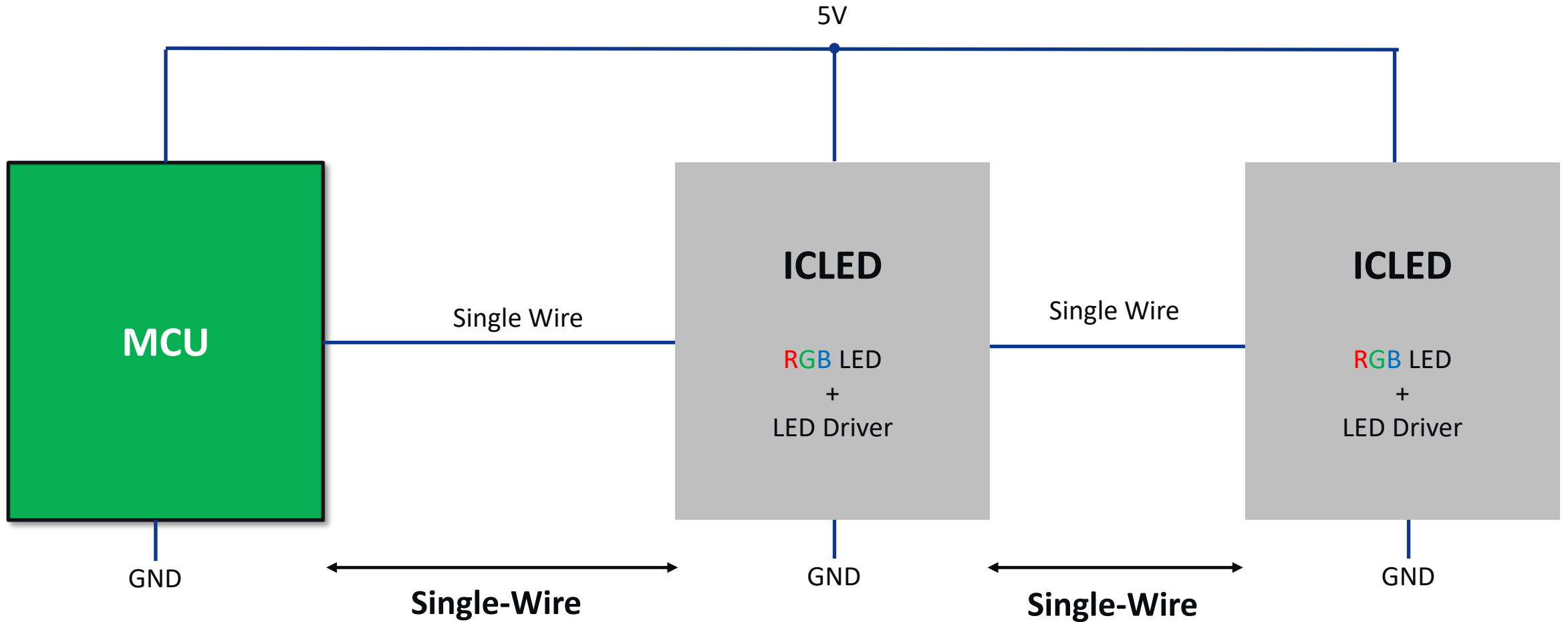

ISC3535 with CLC on PIC16F18325

- Based on PIC16F18325

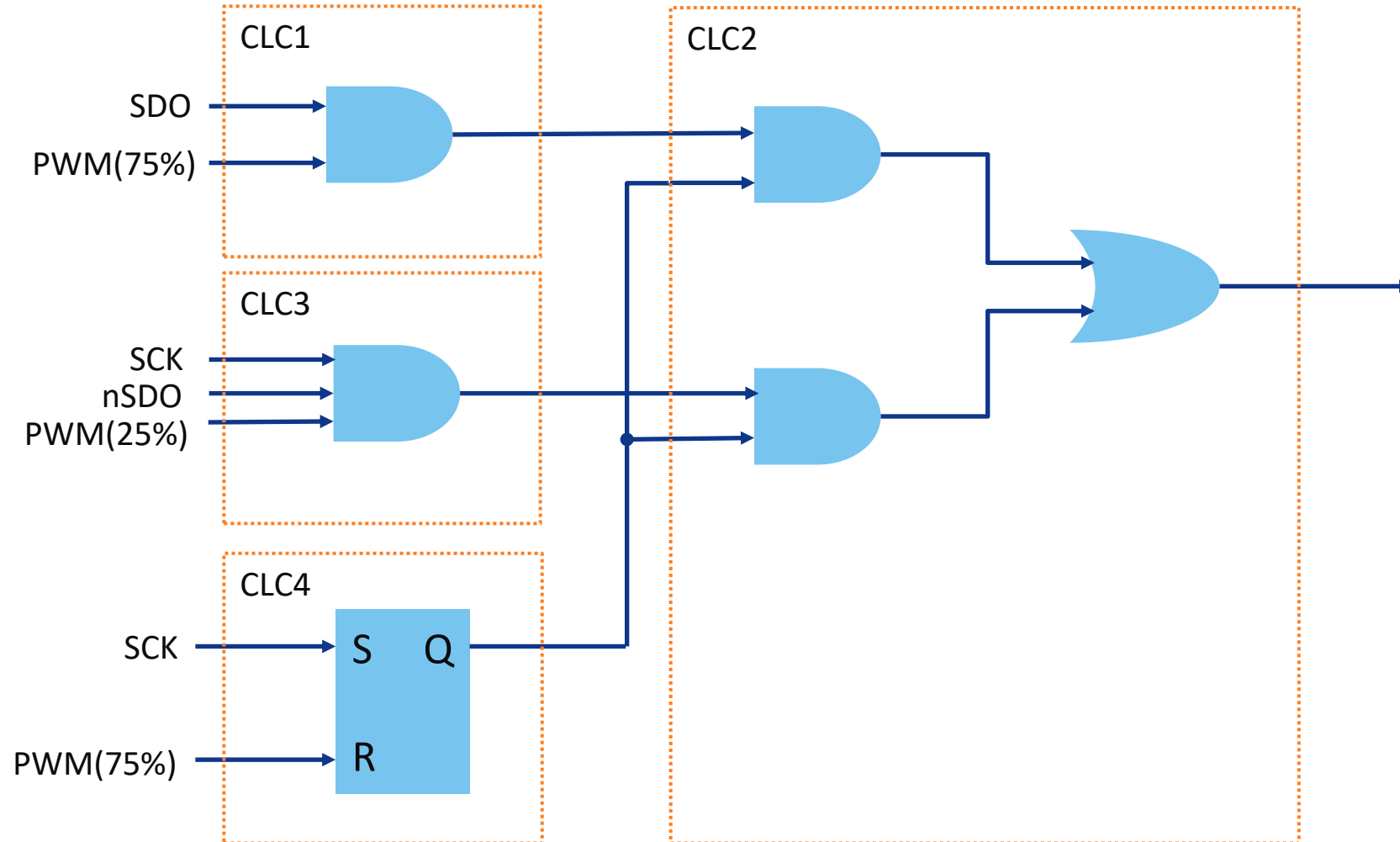

ISC3535 with CLC on PIC16F18325

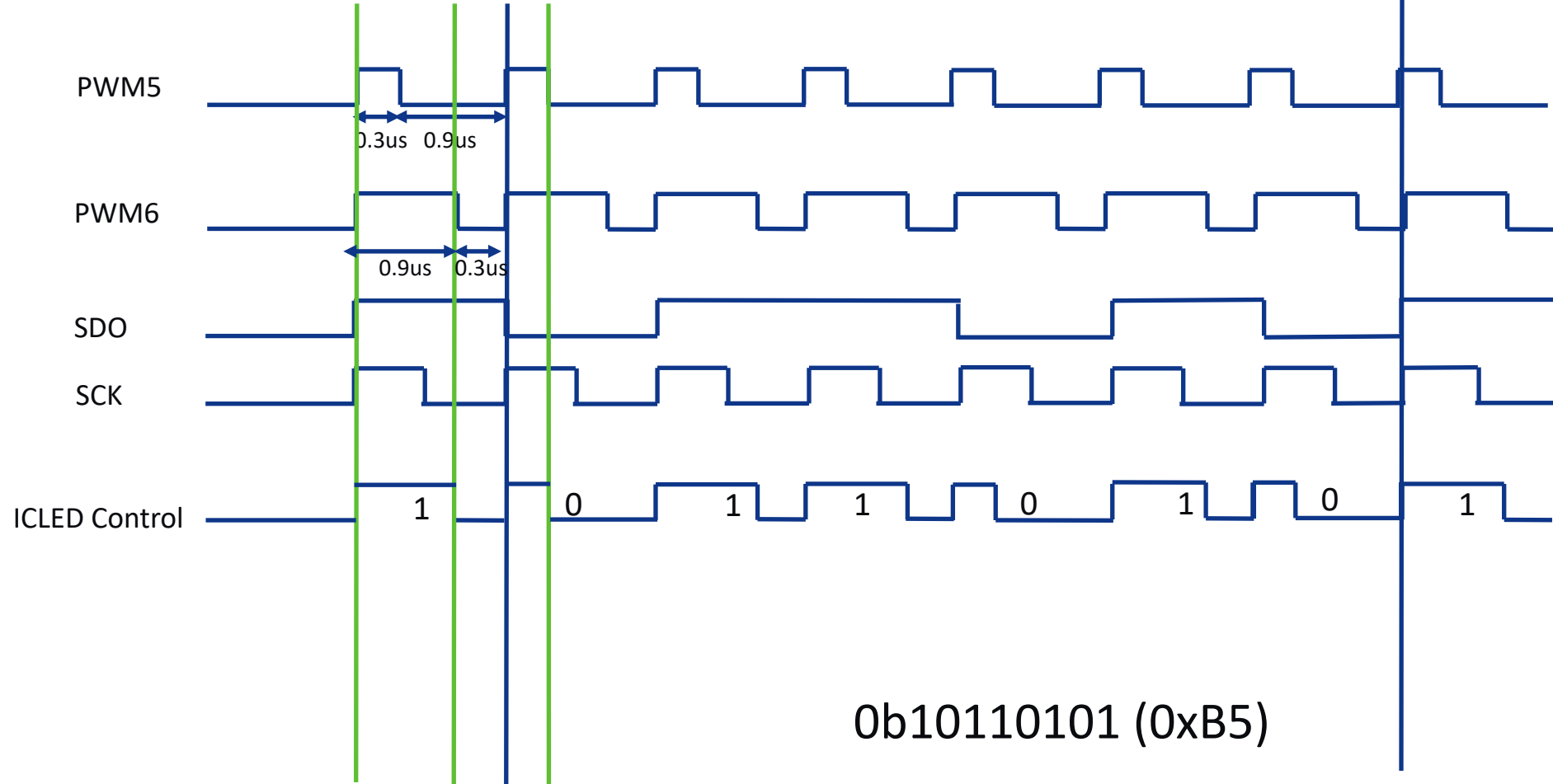

0: SDO & PWM5
1: SDO & PWM6

SCK

ISC3535

- Based on PIC16F18325

PIC16(L)F183XX Family Types

Device	Data Sheet Index	Program Flash Memory (Words)	Program Flash Memory (Kbytes)	Data Memory (bytes)	Data SRAM (bytes)	I/Os ⁽²⁾	10-bit ADC (ch)	5-bit DAC	High-Speed/Comparators	CWG	Clock Ref	Timers (8/16-bit)	CCP	10-bit PWM	NCO	EUSART	I ² C/SPI	CLC	DSM	PPS	XLP	PMD	Idle and Doze	Debug ⁽¹⁾
PIC16(L)F18313	(1)	2048	3.5	256	256	6	5	1	1	1	1	2/1	2	2	1	1	1/1	2	1	Y	Y	Y	Y	I
PIC16(L)F18323	(1)	2048	3.5	256	256	12	11	1	2	1	1	2/1	2	2	1	1	1/1	2	1	Y	Y	Y	Y	I
PIC16(L)F18324	(2)	4096	7	256	512	12	11	1	2	2	1	4/3	4	2	1	1	1/1	4	1	Y	Y	Y	Y	I
PIC16(L)F18325	(3)	8192	14	256	1024	12	11	1	2	2	1	4/3	4	2	1	1	2/2	4	1	Y	Y	Y	Y	I
PIC16(L)F18326	(4)	16384	28	256	2048	12	15	1	2	2	1	4/3	4	2	1	1	2/2	4	1	Y	Y	Y	Y	I
PIC16(L)F18344	(2)	4096	7	256	512	18	17	1	2	2	1	4/3	4	2	1	1	1/1	4	1	Y	Y	Y	Y	I
PIC16(L)F18345	(3)	8192	14	256	1024	18	17	1	2	2	1	4/3	4	2	1	1	2/2	4	1	Y	Y	Y	Y	I
PIC16(L)F18346	(4)	16384	28	256	2048	18	21	1	2	2	1	4/3	4	2	1	1	2/2	4	1	Y	Y	Y	Y	I

*CLC: Configurable Logic Cell

CLC2 – Based on PIC16F18325

The screenshot displays the MPLAB X IDE interface for configuring a PIC16F18325. The central workspace shows a schematic diagram of the PIC16F18325 with various modules connected, including MSSP1 (SPI), TMR2, EUSART_Peripheral, UART1, PWM5, PWM6, CLC3, CLC1, and CLC4. The right-hand panel shows the CLC Settings for CLC2, including options for Enable CLC, Logic Cell Mode bits (AND-OR), and Interrupt Settings (Enable CLC Interrupt, Enable Rising Interrupt, Enable Falling Interrupt). A red box highlights a logic diagram for LC3_out, LC4_out, LC1_out, and LC4_out, showing a series of AND and OR gates.

At the bottom, the Pin Package View table is shown:

Package:	SOIC14	Pin No:	13	12	11	10	9	8	7	6	5			
			PORTA				PORTC							
			0	1	2	3	4	5	0	1	2	3	4	5
MSSP1		SCK1	in/out											
		SDI1	input											
		SDO1	output											
CLC4		CLC4	output											
		CLCIN0	input											
CLC3		CLCIN0	input											
		CLCIN1	input											
CLC2		CLC2	output											
		CLC1	output											
		CLCIN0	input											
		CLCIN1	input											
PWM5		PWM5OUT	output											
PWM6		PWM6OUT	output											
OSC		CLKOUT	output											
DETECT		MAP0	input											

CLC3 – Based on PIC16F18325

The screenshot displays the MPLAB X IDE interface for configuring the CLC3 module on a PIC16F18325. The central workspace shows the system firmware connection diagram with various modules like MSSP1, PWM5, PWM6, CLC1, CLC2, CLC3, CLC4, and UART1 connected to the PIC16F18325 chip. The right-hand panel shows the CLC Settings for CLC3, including options for enabling the CLC, setting the Logic Cell Mode bits to 4-input AND, and configuring interrupt settings. A red box highlights a logic diagram showing the internal structure of CLC3, which consists of four 4-input AND gates (labeled 1, 2, 3, and 4) whose outputs are combined through a series of OR gates to produce the final CLC3 output.

The bottom Pin Grid View table provides a detailed mapping of module functions to specific pins:

Package:	SOIC14	Pin No:	13	12	11	4	3	2	10	9	8	7	6	5
Module	Function	Direction	0	1	2	3	4	5	0	1	2	3	4	5
MSSP1	SCK1	in/out												
MSSP1	SDI1	input												
MSSP1	SDO1	output												
CLC4	CLC4	output												
CLC3	CLCIN0	input												
CLC3	CLC3	output												
CLC2	CLCIN1	input												
CLC2	CLC2	output												
CLC1	CLCIN0	input												
CLC1	CLCIN1	input												
PWM5	PWMSOUT	output												
PWM6	PWM6OUT	output												
OSC	CLKOUT	output												
DETECT	MCPID	input												

CLC4 – Based on PIC16F18325

MPLAB X IDE v6.20 - icled: default

File Edit View Navigate Source Refactor Production Debug Team Tools Window Help

Search (Ctrl+F)

Projects Files Services Resource Mana... x Kit Window x main.c x GD31oc.c x GD31oc.h x Start Page x main.c x nvm.c x nvm.h x Builder x

MCC v5.5.0

Project Resources Generate

Drivers

- CLC1
- CLC2
- CLC3
- CLC4

MSSP

- PWM5
- PWM6

Timer

Device Resources Content Manager

Libraries

- Data Visualizer
- Generic Driver Interfaces

Drivers

- ADC
- CCP
- Clock Reference
- Comparator
- CWIG
- DAC
- DSM
- FVR
- I2C
- MSSP
- NCO

Microchip PIC16F18325

System Firmware

MSSP1 (SPI)

PWM5

PWM6

TMR2

TMR0

EUSART_Periphe rdi

UART1

CLC3

CLC2

CLC1

CLC4

Easy View Register Initialization

Software Settings

Custom Name CLC4

CLC Settings

Enable CLC

Logic Cell Mode bits SR latch

Interrupt Settings

Enable CLC Interrupt

Enable Rising Interrupt

Enable Falling Interrupt

Export CLC image

CLCIN0 (CLCIN0PPS) 1

CLCIN0 (CLCIN0PPS) 2

PWM6 output 3

CLCIN0 (CLCIN0PPS) 4

Controls

Pan: Right-click and drag grid

Zoom: Scroll

icled - Dashboard Pin Package View x

Package: SOIC14

Export Image

RA5 2 13 RA0 | SCK1

RA4 3 12 RA1 | SDO1

RA3 | MCLR 4 11 RA2

RC5 | RX 5 10 RC0

RC4 | TX 6 9 RC1

RC3 7 8 RC2 | CLC2

Search Results Output Notifications [MCC] Pin Grid View x

Module	Function	Direction	PORTA					PORTC							
			0	1	2	3	4	5	0	1	2	3	4	5	
MSSP1	SCK1	in/out													
	SDI1	input													
	SDO1	output													
CLC4	CLC4	output													
	CLCIN0	input													
	CLC3	output													
CLC3	CLCIN0	input													

EE Data Memory x

Address	00	01	02	03	04	05	06	07	08	09	0A	0B	0C	0D	0E	0F	ASCII
F000	FF	FF	FF	FF	FF	FF	FF	FF	FF	FF	FF	FF	FF	FF	FF	FF
F010	FF	FF	FF	FF	FF	FF	FF	FF	FF	FF	FF	FF	FF	FF	FF	FF
F020	FF	FF	FF	FF	FF	FF	FF	FF	FF	FF	FF	FF	FF	FF	FF	FF
F030	FF	FF	FF	FF	FF	FF	FF	FF	FF	FF	FF	FF	FF	FF	FF	FF
F040	FF	FF	FF	FF	FF	FF	FF	FF	FF	FF	FF	FF	FF	FF	FF	FF
F050	FF	FF	FF	FF	FF	FF	FF	FF	FF	FF	FF	FF	FF	FF	FF	FF
F060	FF	FF	FF	FF	FF	FF	FF	FF	FF	FF	FF	FF	FF	FF	FF	FF
F070	FF	FF	FF	FF	FF	FF	FF	FF	FF	FF	FF	FF	FF	FF	FF	FF
F080	FF	FF	FF	FF	FF	FF	FF	FF	FF	FF	FF	FF	FF	FF	FF	FF
F090	FF	FF	FF	FF	FF	FF	FF	FF	FF	FF	FF	FF	FF	FF	FF	FF

Memory EE Data Memory Format

Filter Address

Direct Memory Access Controller on 8-bit MCU

Moves data between memories & peripherals w/o CPU

Direct Memory Access Controller (DMA)

- **Eliminates need for CPU involvement in data transfers**
- **Access to all memory spaces and peripherals**
 - Read Flash and Data EEPROM
 - Read / Write RAM and peripherals
- **All interrupts sources are available as trigger and abort**
 - Programmed for complex data transfers
- **Flexible source and destination message sizes**
 - Programmable DMA priority
- **Allows user to set operation precedence**

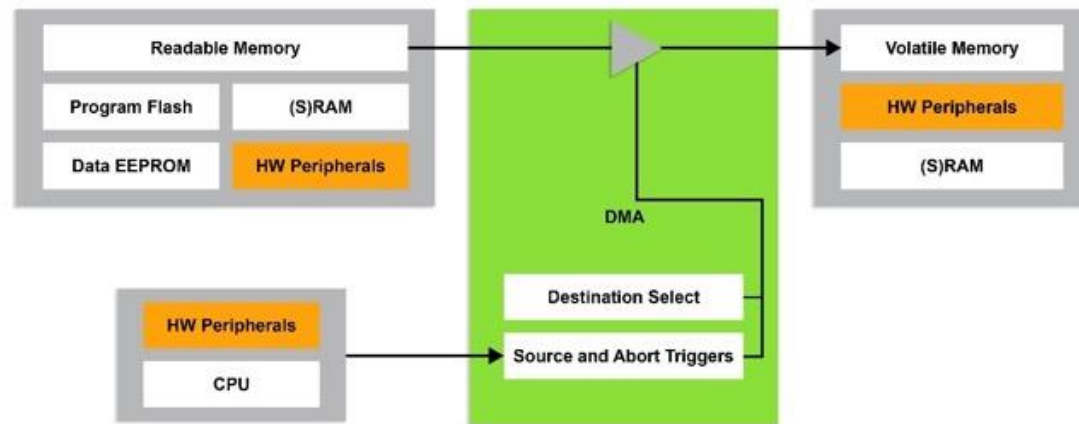

Benefits

- **Reduced number of interrupts**
 - Better real-time performance
 - Minimize latency in data transfers
- **Improved Peripheral Performance**
 - Automate peripheral operation
 - Multiple peripherals operate together
- **Improves power consumption**

Example Uses

- **Data logging**
- **Automated analog sampling**
- **Arbitrary function generation**
 - Motor Control
 - LED Dimming
- **Communication bridge:**
 - RS-485, DMX, DALI, I2C, SMBus, SPI, LIN, UART
- **Dynamic frequency generation**

Microchip ICLED Recommendation

UART/SPI Interface

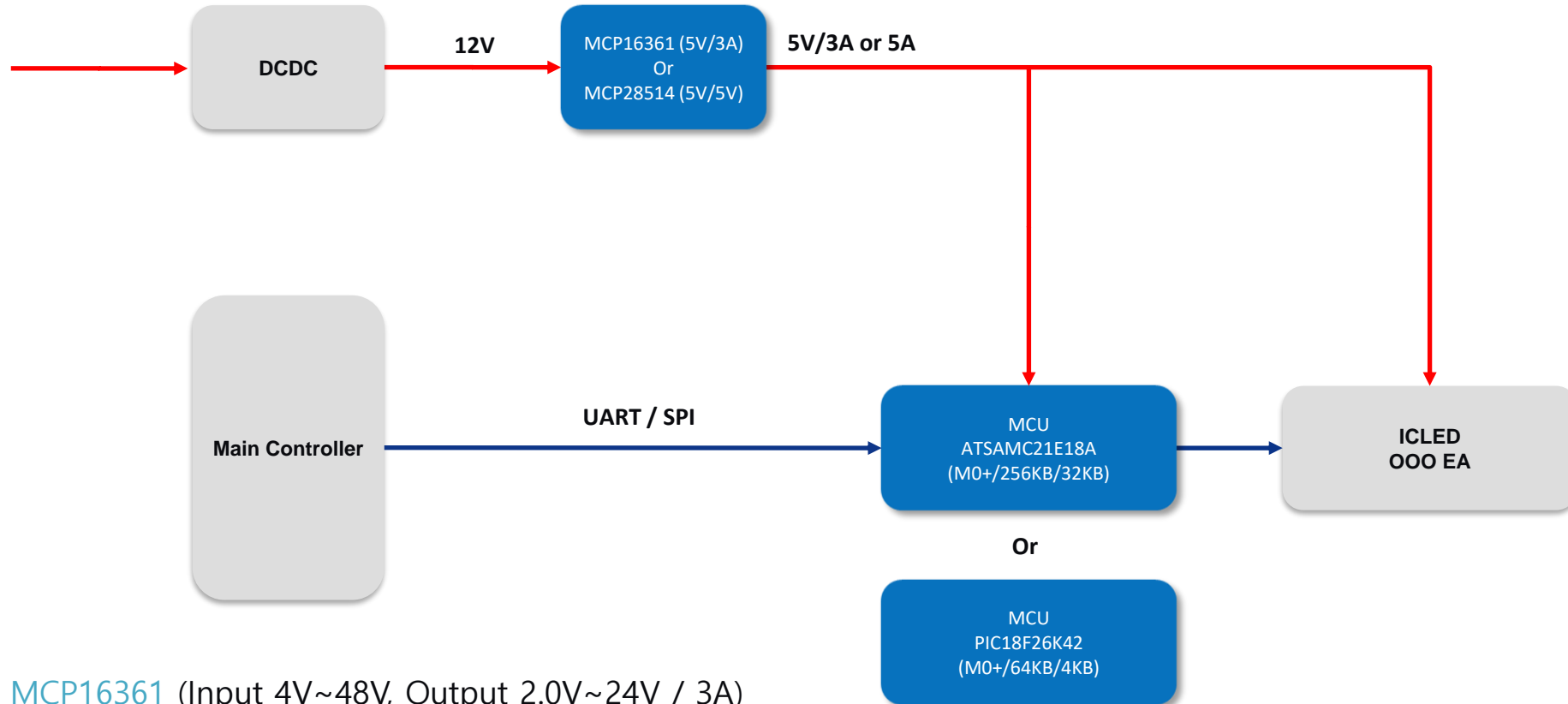

[MCP16361](#) (Input 4V~48V, Output 2.0V~24V / 3A)

[MCP28514](#) (Input 4.5V~75V, Output 0.6V~32V / 5A)

Microchip ICLED Recommendation

CAN Interface

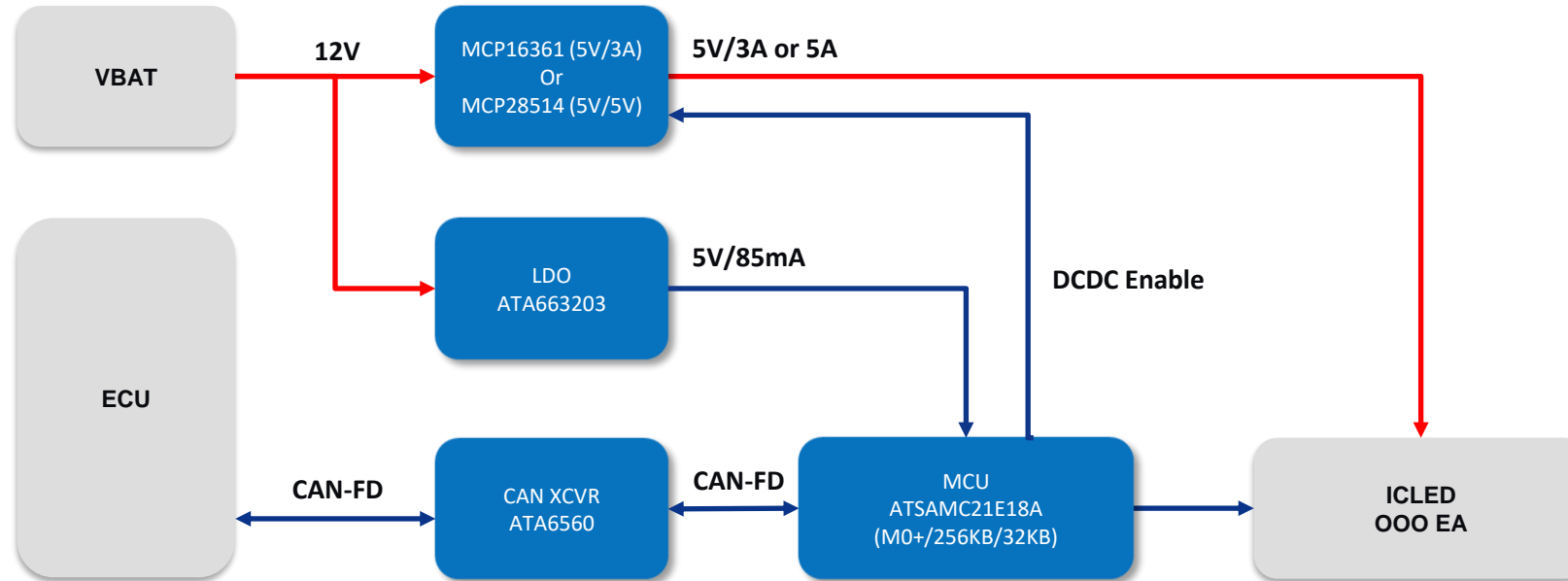

[MCP16361](#) (Input 4V~48V, Output 2.0V~24V / 3A)

[MCP28514](#) (Input 4.5V~75V, Output 0.6V~32V / 5A)

Microchip ICLED Recommendation

LIN Interface

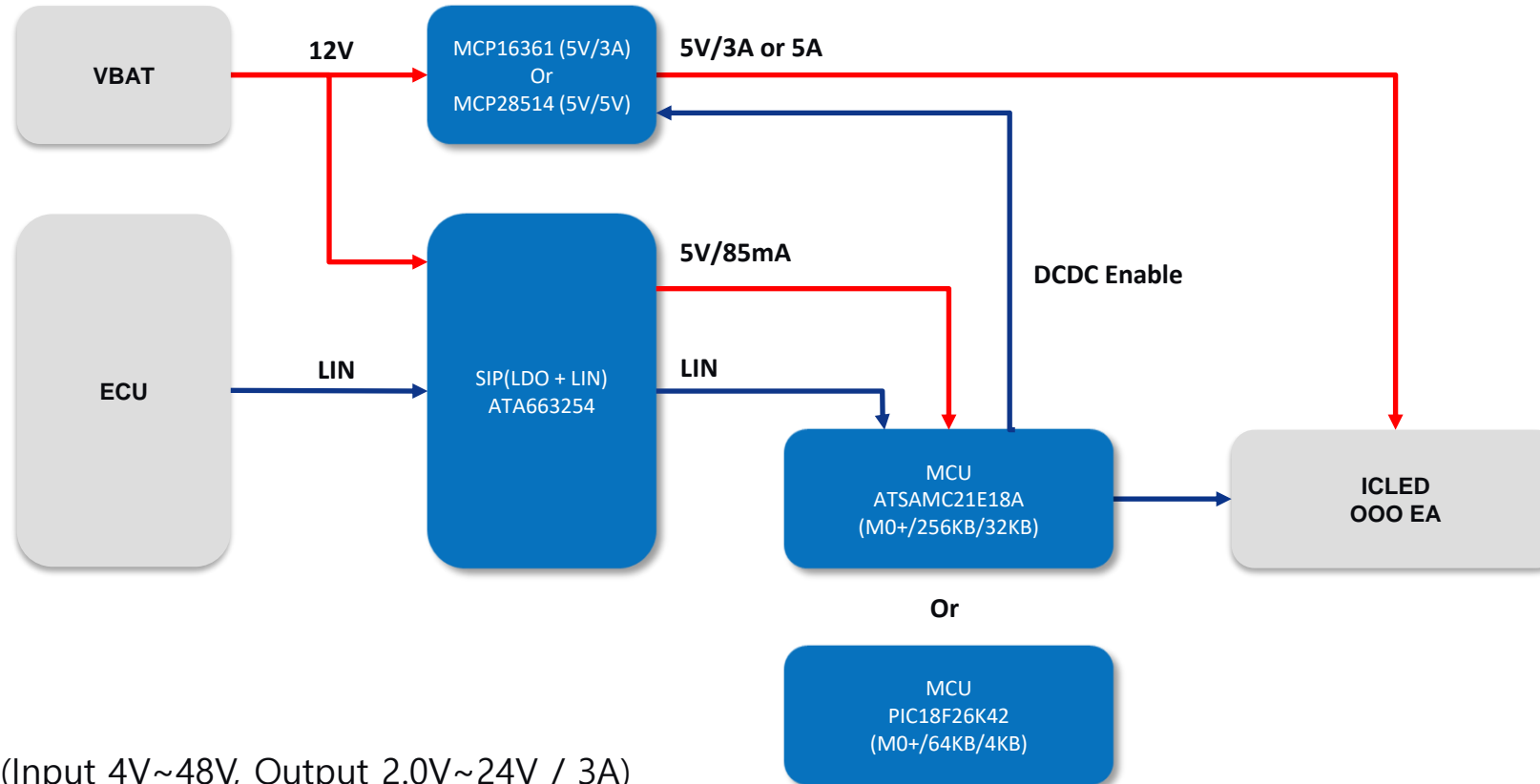

[MCP16361](#) (Input 4V~48V, Output 2.0V~24V / 3A)

[MCP28514](#) (Input 4.5V~75V, Output 0.6V~32V / 5A)

ICLED Solution

ATSAMC21G17A for ICLEDs & Touch and Proximity

- Easy Evaluation board preview

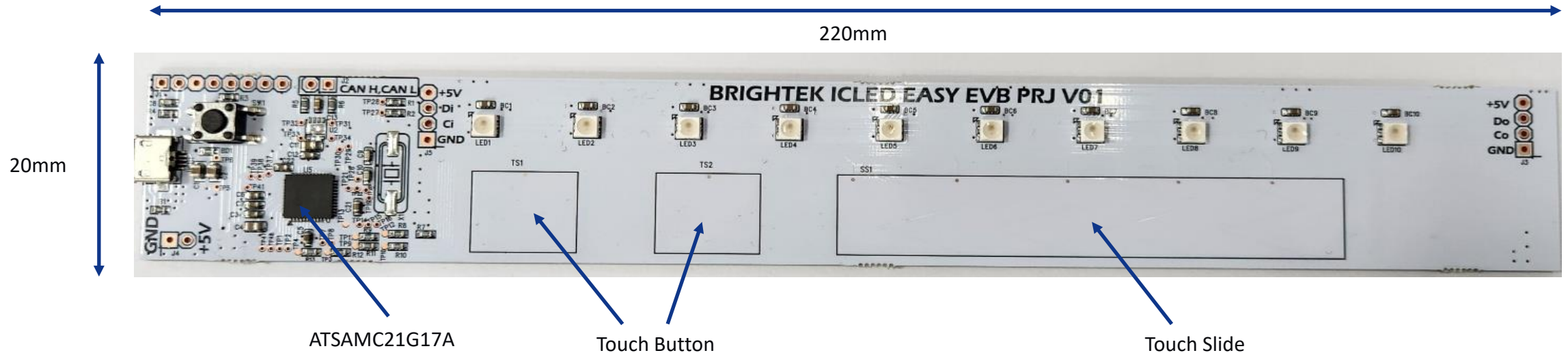

ICLED Connection

IC LED for Diagnostic

Case 1:

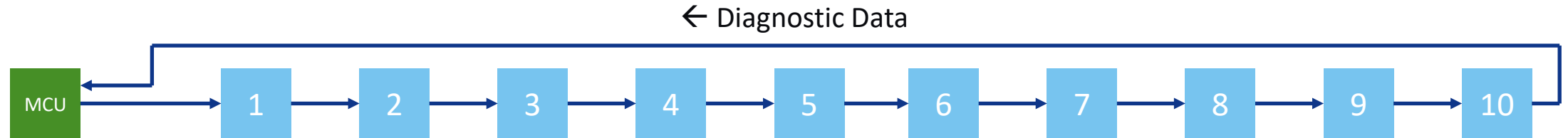

Case 2:



ICLED Connection

IC LED Multi Connection

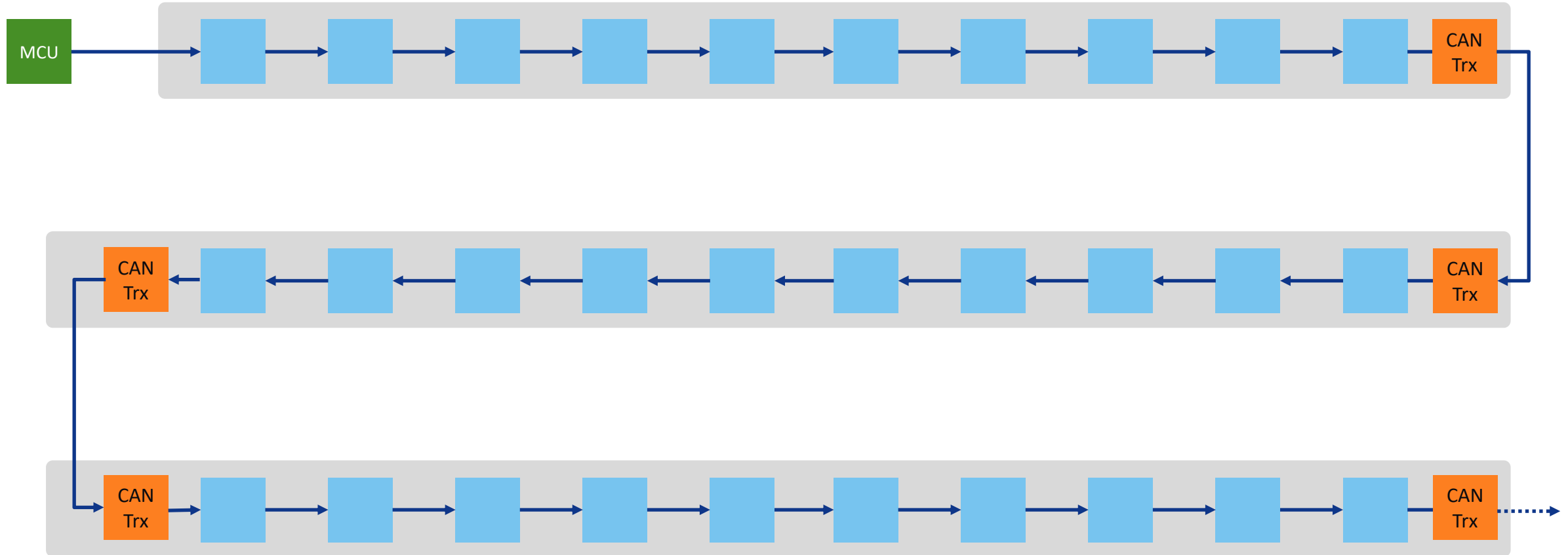

Thank You

Contact: 마이크로칩 기술부 신기원 책임
Kenny.Shin@microchip.com