



Kinetis MCUs

The World's Broadest ARM-based MCU Portfolio

Hansop Shim | MCU Marketing

OCT. 2014



Confidential and Proprietary

Freescale, the Freescale logo, ARMv6, C-S, CodeTEST, CodeWarrior, ColdFire, ColdFire+, C-Ware, the Energy Efficient Solutions logo, Kinetis, iM68K07, PEG, PowerQUICC, Processor Expert, QorIQ, Qorliva, SafeAssure, the SafeAssure logo, StarCore, Symphony and Vorteo are trademarks of Freescale Semiconductor, Inc., Reg. U.S. Pat. & Tm. Off. Altera, BittNet, BlackBox, CoreNet, Flexio, Layerscape, MagniV, MKC, Platform in a Package, QorIQ Gateway, QorIQ Engine, Ready Plug, SMARTMOS, Tower, TriadLink, UMEMI, Vybrid and Xilinx are trademarks of Freescale Semiconductor, Inc. All other product or service names are the property of their respective owners. © 2014 Freescale Semiconductor, Inc.



- 
- Kinetis MCU Portfolio Overview
 - MCU Market Trend
 - Kinetis Mini MCUs for IoT
 - MCU Software & Tools
 - Kinetis MCU Product Lines
 - Kinetis K Series MCUs
 - Kinetis L Series MCUs
 - Kinetis E Series MCUs
 - Kinetis V Series MCUs
 - Kinetis W Series MCUs
 - Kinetis M Series MCUs
 - Kinetis MCU Enablement



Kinetis MCU Portfolio Overview

Design Potential. Realized.



Confidential and Proprietary

Freescale, the Freescale logo, ARVoc, C-E, CodeTEST, CodeWarrior, CodeFire, CodeFree+, C-Ware, the Energy Efficient Solutions logo, Kinetis, i68kMOT, PEG, PowerQUICC, Processor Expert, QorIQ, QorNova, SafeAssure, the SafeAssure logo, StarCore, Symphony and Vybrid are trademarks of Freescale Semiconductor, Inc., Reg. U.S. Pat. & Tm. Off. AirStar, BeeKit, Beeduck, CoreNet, Flexis, Layerscape, MagniV, MKC, Platform in a Package, QorIQ Gateway, QorIQ Engine, Ready Plug, SMARTMOS, Tower, TriadLink, UMEMR, Vybrid and Xtrinsic are trademarks of Freescale Semiconductor, Inc. All other product or service names are the property of their respective owners. © 2014 Freescale Semiconductor, Inc.



Kinetis Microcontrollers

World's Broadest ARM® Cortex®-M-based Portfolio

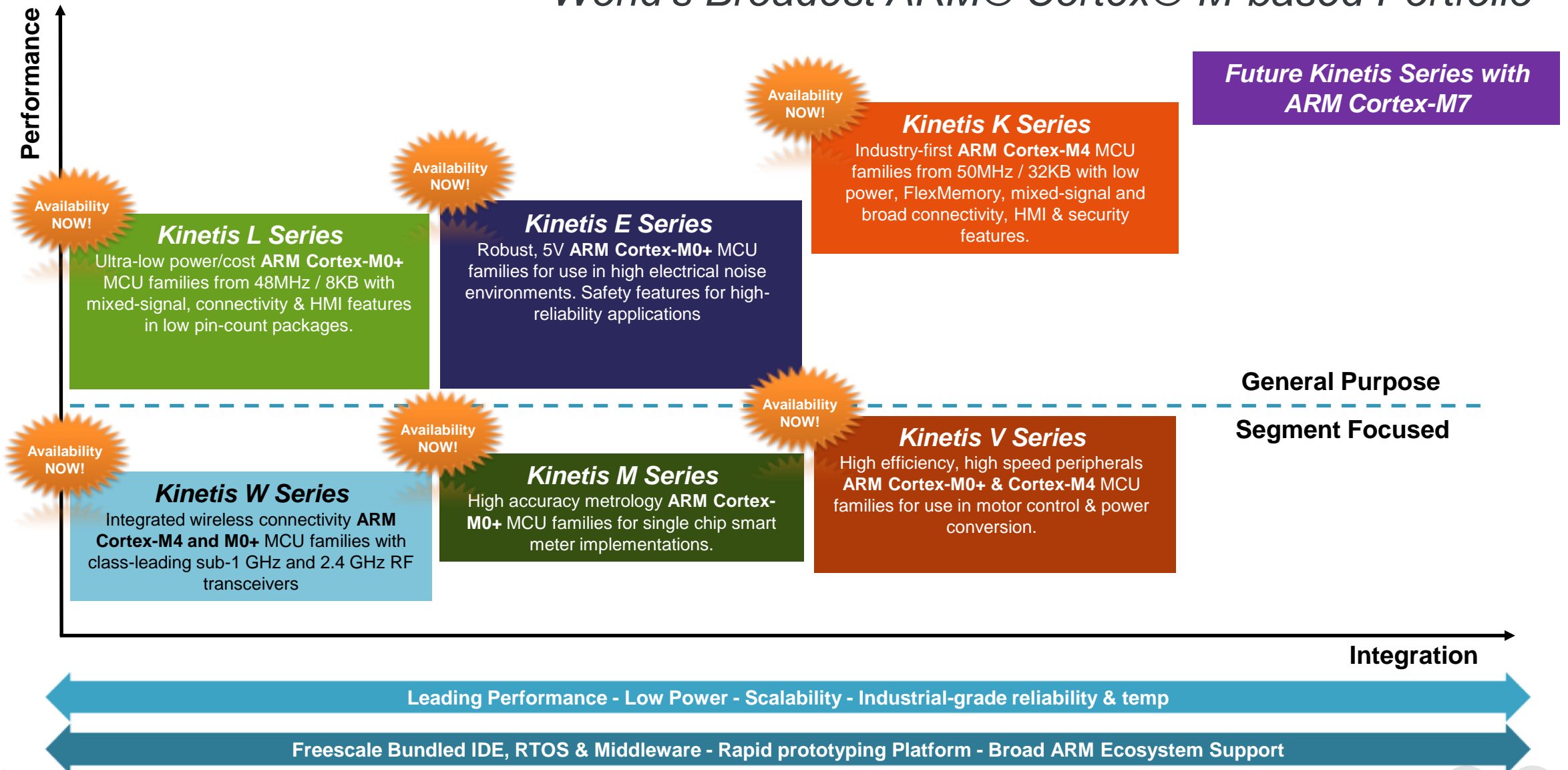



Kinetis MCU Key Pillars by Series'

L	E	K	W	M	V
Low Power	5V Robustness	High Performance & Rich Integration	Integrated RF Connectivity	Integrated metrology engine	Motor and Power Conversion
48MHz Cortex M0+	Up to 48MHz Cortex M0+	Up to 180MHz Cortex M4	Up to 50MHz Cortex M4, Cortex M0+	Up to 48MHz Cortex M0+	Up to 200MHz, Cortex M4, Cortex M0+
8KB to 512kB Flash	8KB to 128kB Flash	32KB to 2MB Flash	32KB to 512kB Flash	32KB to 128kB Flash	16KB to 2MB Flash
Up to 128KB RAM	Up to 16KB RAM	Up to 256KB RAM	Up to 64KB RAM	Up to 32KB RAM	Up to 256KB RAM
Now!	Now!	Now!	Now!	Now!	Now!

Leading Performance – Low Power – Scalability – Industrial Grade reliability & temp

Freescale Bundled IDE, RTOS & Middleware – Rapid Prototyping Platform – Broad ARM Ecosystem Support

Kinetis MCU General Purpose Product Lines

	Kinetis L Series	Kinetis E Series	Kinetis K Series
Processor	ARM Cortex-M0+	ARM Cortex-M0+	ARM Cortex-M4 (with optional SPFPU)
Performance	Up to 48MHz	Up to 48MHz	Up to 50 / 72 / 100 / 120 / 150 / 180MHz
Ultra Low Power	Typical ~50uA/MHz (VLPR Mode)	na	Typical ~130uA/MHz (VLPR Mode)
Memory	8kB – 256kB Flash 1kB – 32kB SRAM	8kB – 128kB Flash 1kB – 16kB SRAM	32kB – 2MB Flash 8kB – 256kB SRAM
Pin-Count	16 – 121 Pin	16 – 80 Pin	32 – 256 Pin
Features	Baseline / Mixed-Signal <i>and optional</i> Segment LCD, USB	5V / EMC / Safety (CRC) Control (FlexTimer) <i>and optional</i> Segment LCD, CAN	Baseline / Mixed-Signal <i>and optional</i> FlexMemory, USB, Segment LCD, CAN, Ethernet, Graph LCD, DRAM-CTRL, NAND-Flash-CTRL, Crypto, Anti-Tamper
Price	<i>From \$0.49</i> (MKL02x, 8KB, 16QFN)	<i>From \$0.78</i> (MKE02x, 16KB, 32LQFP)	<i>From \$0.79</i> (MK02, 64KB, 32QFN)
Demo Board		www.freescale.com/FREEDOM www.freescale.com/TOWER	
	www.freescale.com/KINETIS		

MQX-Lite
+USB and Peripherals Drivers (also
within Processor Expert – Code Generator)

Freescale free
RTOS called MQX
www.freescale.com/MQX
including USB / Ethernet /
MS File System /
Peripherals Driver

Note: Availability device dependent



MCU Market Trend











Confidential and Proprietary

Freescale, the Freescale logo, ARBot, C-S, CodeTEST, CodeWarrior, CodeFis, CodeFis+, C-Ware, the Energy Efficient Solutions logo, Kinetics, i60640T, PEG, PowerQUICC, Processor Expert, QorIQ, Qorlva, SafeAssure, the SafeAssure logo, StarCore, Symphony and Vybrid are trademarks of Freescale Semiconductor, Inc., Reg. U.S. Pat. & Tm. Off. Altera, Avalon, Bedrock, CoreNet, Flexio, Layerscape, MagiW, MKC, Platform in a Package, QorIQ Gateway, QorIQ Engine, Ready Plug, SMARTMOS, Tower, TriadLink, UMEME, Vybrid and Xilinx are trademarks of Freescale Semiconductor, Inc. All other product or service names are the property of their respective owners. © 2014 Freescale Semiconductor, Inc.



Implications for Entry-Level MCUs

	8/16-bit MCUs		32-bit MCUs
Connectivity		→	  Bluetooth 
User Interface		→	 
Power Consumption	 Ultra-low sleep/ power-down currents	→	 Maximum Energy efficiency (CoreMark®/mW)
Computation	$+$ \times $-$ \div	→	$\sqrt{\quad}$ \int_x^n \sin \log_n
Software/Cost of Ownership	Unique platforms, MCU dependent/\$\$\$	→	Scalable, reusable platforms with modern software techniques/\$
Scalability	Limited choice, single source	→	Broad MCU portfolios, multi-source

32-bit MCU in Low power and Low cost market

32-bit

Energy efficiency

Class-leading CoreMark/mW

Scalability and integration

Kinetis L to K Series MCUs (ARM Cortex-M0+ to Cortex-M4)

Enablement

Freescale bundle + ARM ecosystem

Kinetis L Series MCUs

The evolution of the entry-level MCU

8-bit

Ultra-low static

<1uA

Low cost

From <\$0.50

Ease of use

Freedom Platform, Processor Expert and MCU Solution Advisor



Going **Green**



Health & **Safety**



Net **Effect**



Smaller package, Low power consumption

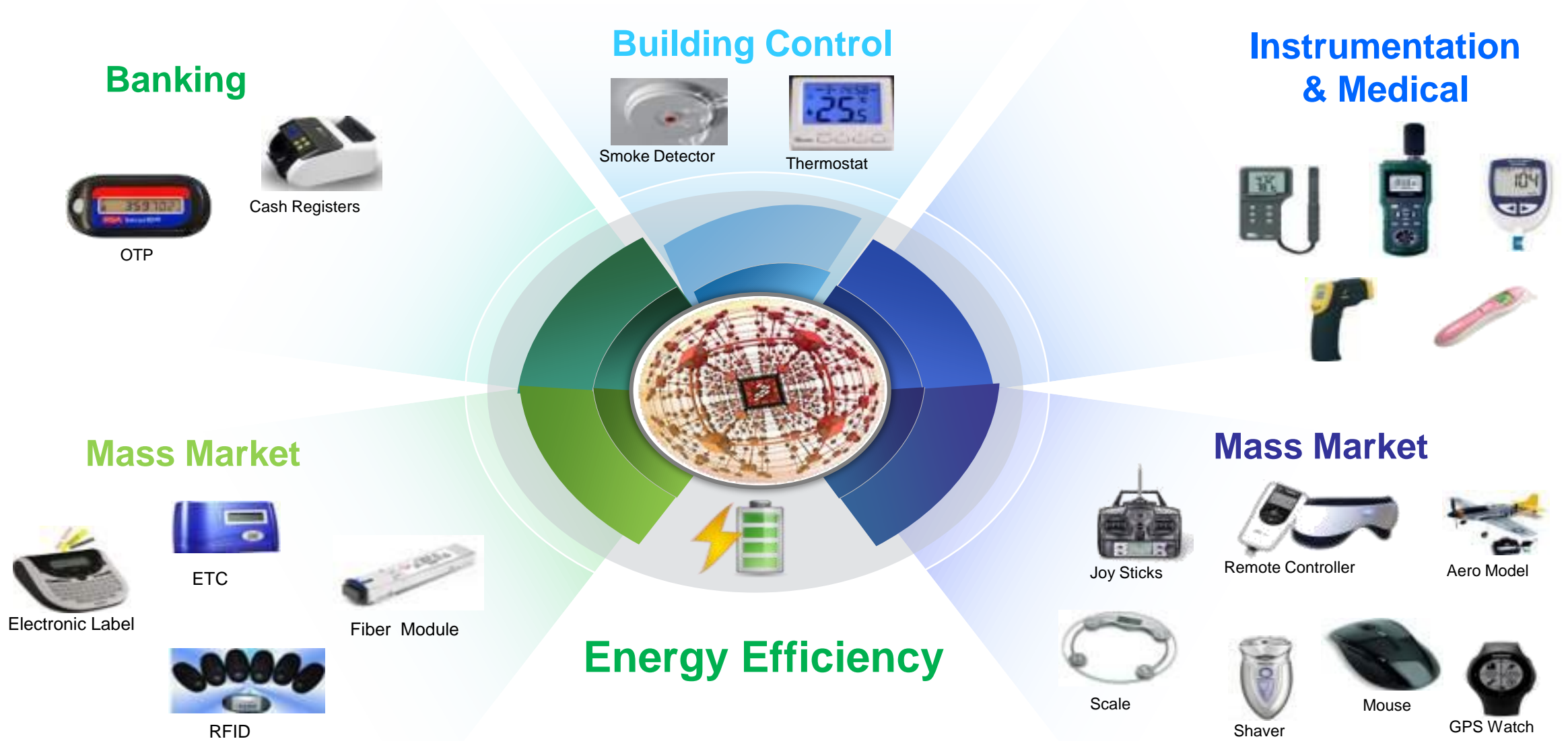

The ARM Cortex-M0+ Core: No compromise in performance

Shorten run time in low-power applications.

- **More than 2x CoreMark/mA performance** than the closest 8/16-bit competitor
- **2-stage pipeline**—reduced number of cycles per instruction (CPI) enables faster branch instruction and ISR entry, reduced power consumption and increased performance
- **Fast I/O port**—single-cycle access to I/O (**2x faster than normal I/O**)
 - Improves reaction time to external events, allowing bit-banding and software protocol emulation
 - Implemented as **FGPIO** on **Kinetis L series MCUs**

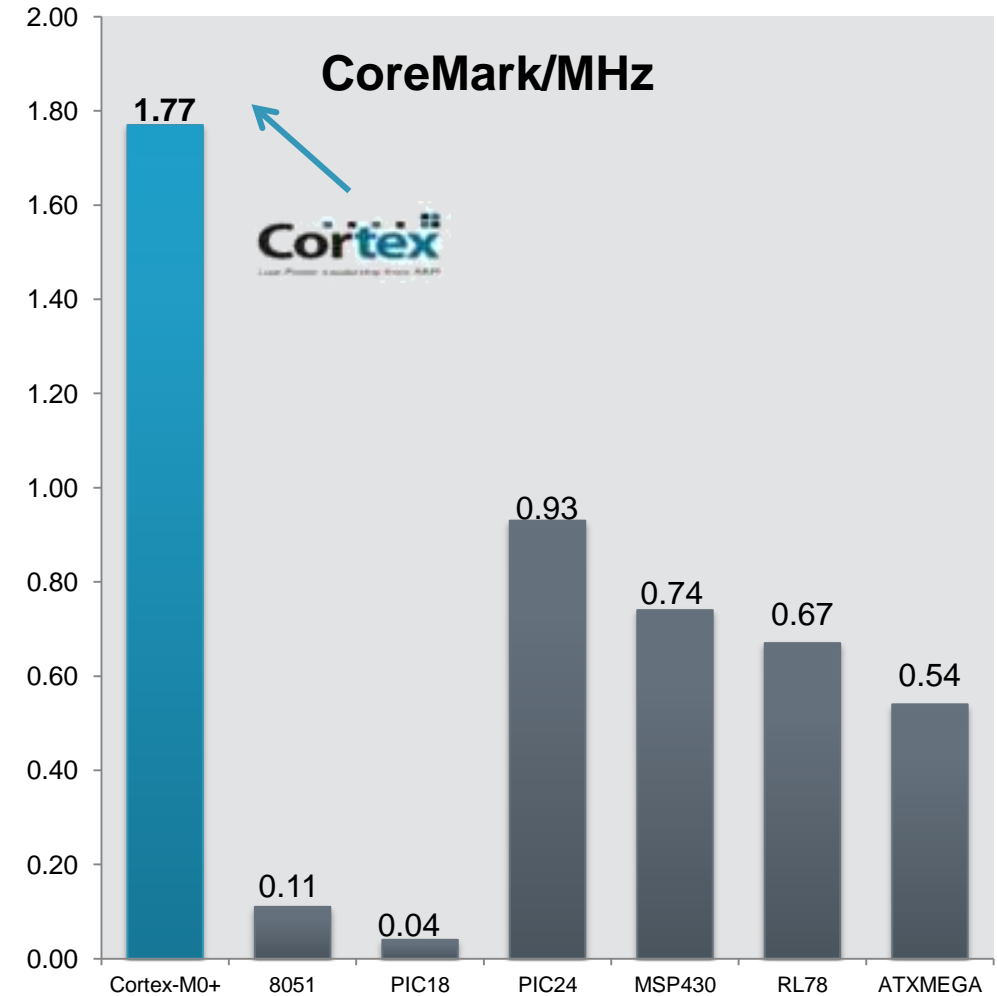

Official data: www.coremark.org

Kinetis L Series

ARM Cortex-M0+ : What's the "+" stand for?

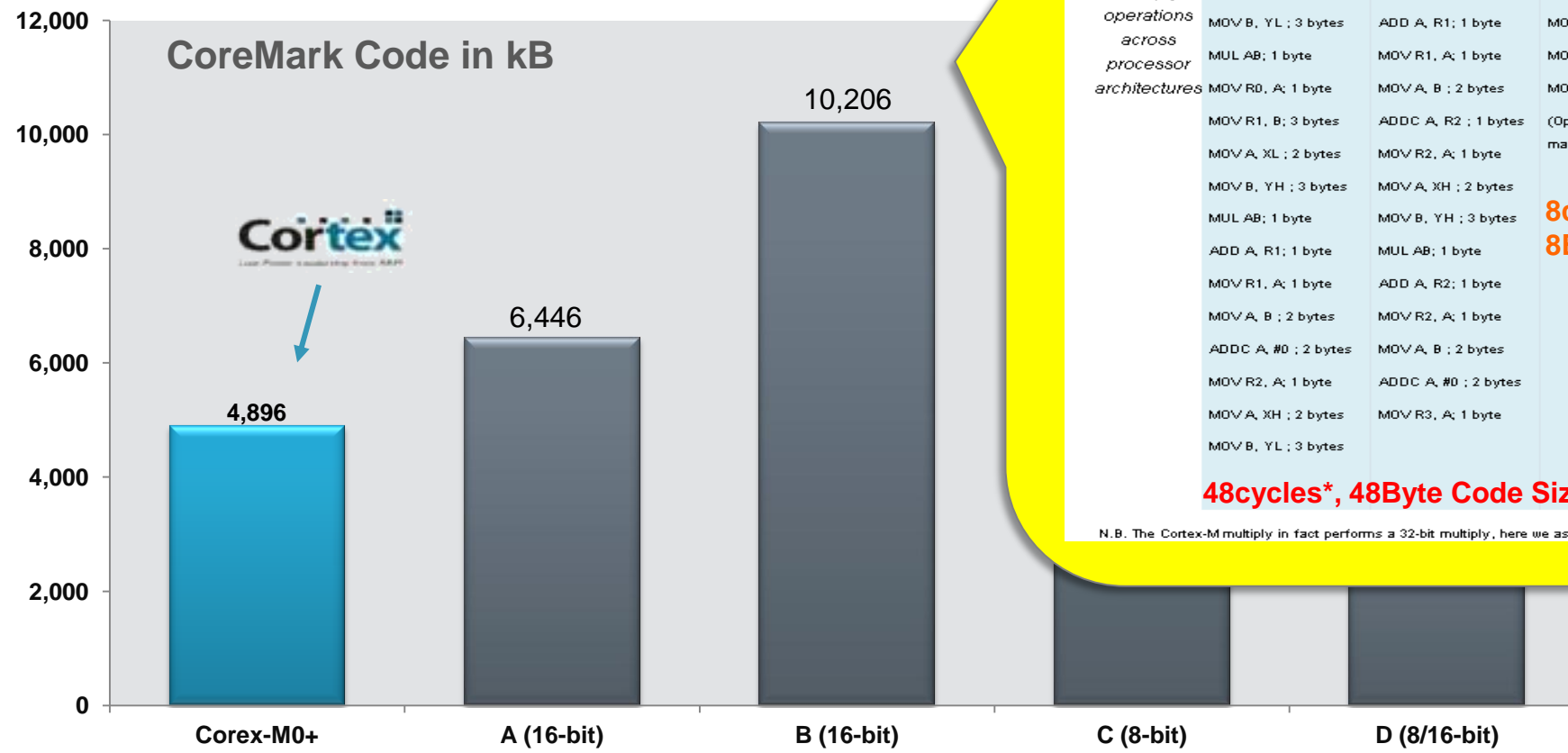

16-bit Multiplication Example

Comparing 16-bit multiply operations across processor architectures	8-bit example	16-bit example	ARM Cortex-M
MOV A, XL ; 2 bytes	MUL AB; 1 byte	MOV R4,#0130h	MULS r0,r1,r0
MOV B, YL ; 3 bytes	ADD A, R1; 1 byte	MOV R5,#0138h	
MUL AB; 1 byte	MOV R1, A; 1 byte	MOV SumLo,R6	
MOV R0, A; 1 byte	MOV A, B ; 2 bytes	MOV SumHi,R7	
MOV R1, B; 3 bytes	ADDC A, R2 ; 1 byte	(Operands are moved to and from a memory mapped hardware multiply unit)	
MOV A, XL ; 2 bytes	MOV R2, A; 1 byte		
MOV B, YH ; 3 bytes	MOV A, XH ; 2 bytes		
MUL AB; 1 byte	MOV B, YH ; 3 bytes	8cycles, 8Byte Code Size	
ADD A, R1; 1 byte	MUL AB; 1 byte		
MOV R1, A; 1 byte	ADD A, R2; 1 byte		
MOV A, B ; 2 bytes	MOV R2, A; 1 byte		
ADDC A, #0 ; 2 bytes	MOV A, B ; 2 bytes		
MOV R2, A; 1 byte	ADDC A, #0 ; 2 bytes		
MOV A, XH ; 2 bytes	MOV R3, A; 1 byte		
MOV B, YL ; 3 bytes			

**1 cycle
2 Byte Code Size**

48cycles*, 48Byte Code Size

*8051 needs at least 1 cycle per instruction byte fetch as they only have an 8-bit interface

N.B. The Cortex-M multiply in fact performs a 32-bit multiply, here we assume r0 and r1 contain 16-bit data.

CoreMark code compiled optimized for size. Same MCUs as for CoreMark/mA benchmark.



Cortex-M4: Efficient Blend

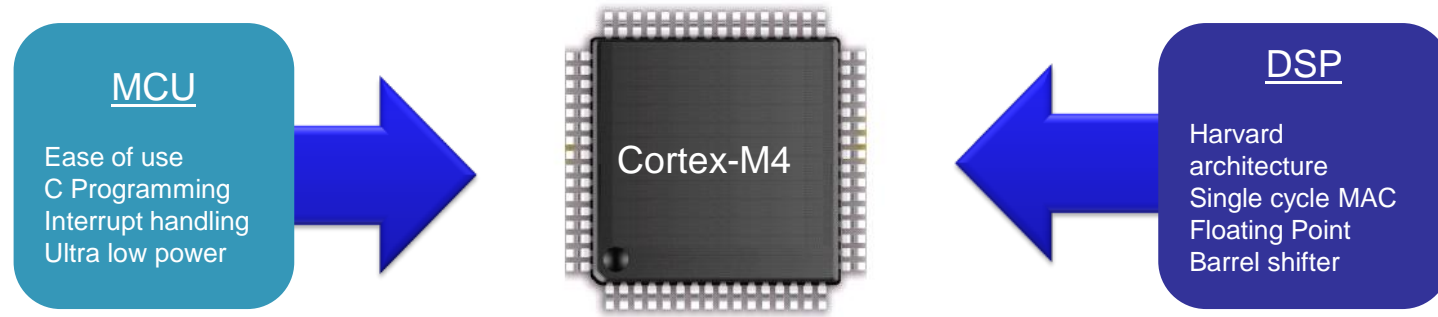

The Cortex-M4 is ~2X more efficient on most DSP tasks than leading 16 and 32 bit MCU devices with DSP extensions

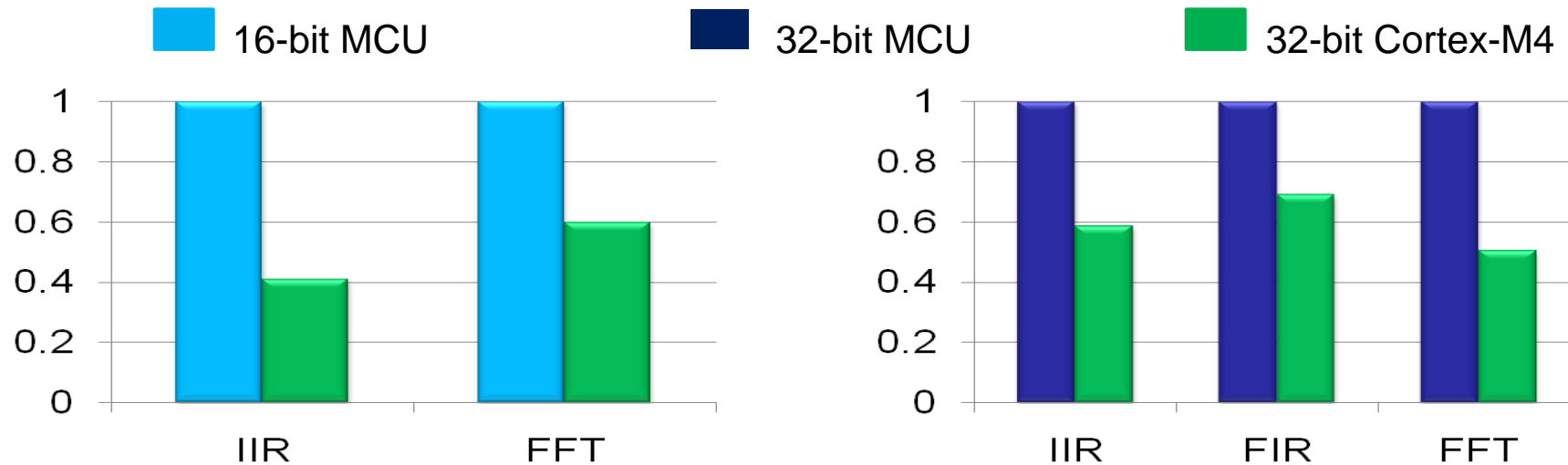

Sensor Hub vs. Sensor Fusion

Sensor Hub (Kinetic L)

A Sensor Hub controls the communication, power, and state of the individual sensors in the system but acts more as a pass through of the data.

- Provides a single unified interface for sensor data regardless of sensor types
- Enables developer to concentrate on using sensor data, not getting sensor data
- Eliminates intensive sensor integration effort
- Provides power management of the platform to achieve lowest power mode of operation
- Create applications with ANY market available sensor

Sensor Fusion (Kinetic K)

A full Sensor Fusion Solution takes in data from 3 or more sensors and provides a calculated output that is calibrated, compensated and calculated depending on the sensors in the system.

- Matrix calculations to determine position and orientation of a device within an earth frame of reference requiring:
 - Quaternion
 - Euler Angles
 - Rotation Matrix
- Calibration and Compensation such as:
 - Ecompass Calibration and Compensation Algorithms
 - Gyro drift calibration
 - Virtual gyro with mag and accel for lower power modes of operation

Freescal Sensor Fusion Solution

- **Sensing Integration / Fusion**
 - Kinetis low power microcontrollers
 - Process sensor fusion algorithms, communicate and control
 - Complete scalable low power solution
 - Mini form factors, starting at 1.6x2.0 CSP package
- **Intelligent Software Framework**
 - Proven platform to facilitate sensor firmware
 - Power management and communications services
 - Scalable over MCU and sensor families
- **Sensors**
 - Stability of temperature/media
 - Low power
 - Broad portfolio
 - Sensor integrated MCUs

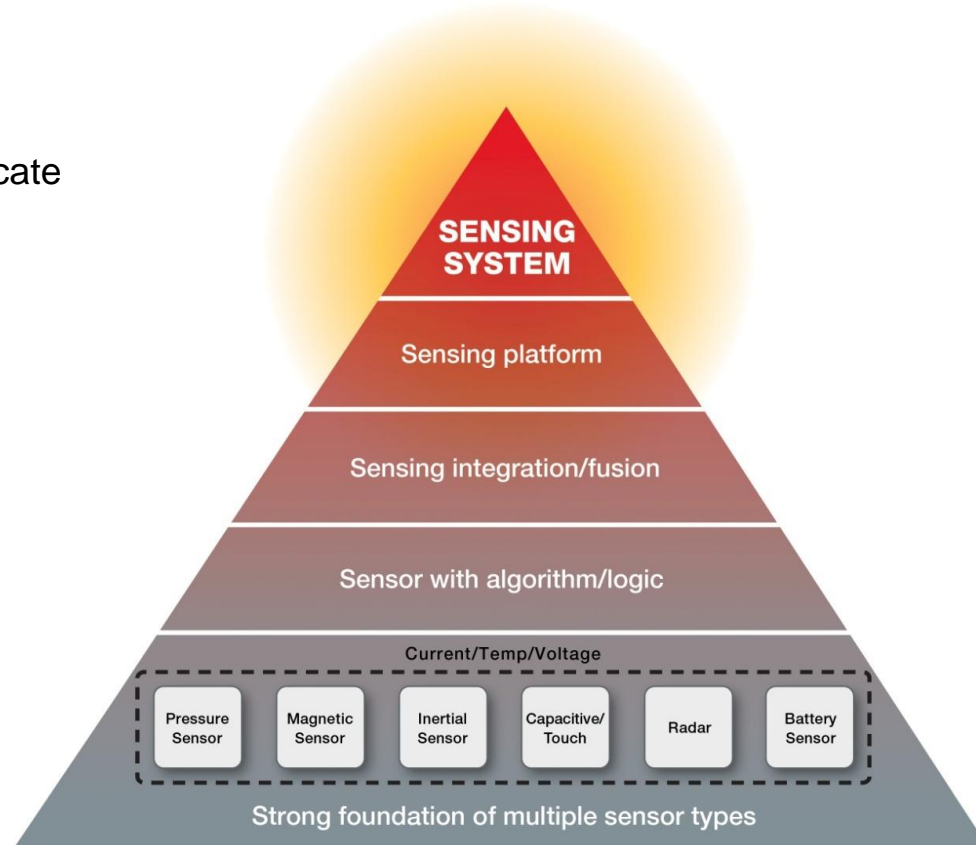



Freescalé Kinetis Mini MCUs for the IoT



Confidential and Proprietary

Freescalé, the Freescalé logo, ARVec, C-E, CodeTEST, CodeWarrior, CodeFire, CodeFree, C-Ware, the Energy Efficient Solutions logo, Kinetis, iMbedIoT, PEG, PowerQUICC, Processor Expert, QorIQ, Qorlva, SafeAssure, the SafeAssure logo, StarCore, Symphony and Vybrid are trademarks of Freescalé Semiconductor, Inc., Reg. U.S. Pat. & Tol. Off. Airbat, Be@t, Be@t@k, CoreNet, Flexis, Layerscape, MagiW, MKC, Platform in a Package, QorIQ Gateway, QorIQ Engine, Ready Plug, SMARTMOS, Tower, TriadLink, UMEMR, Vybrid and Xtrinsic are trademarks of Freescalé Semiconductor, Inc. All other product or service names are the property of their respective owners. © 2014 Freescalé Semiconductor, Inc.



INTERNET of THINGS

It's the *Network of All Networks*, which will be connected through the **Largest Control Data Network in the World**

It's all about the service layer infrastructure, because ...

It's ALL About the Services

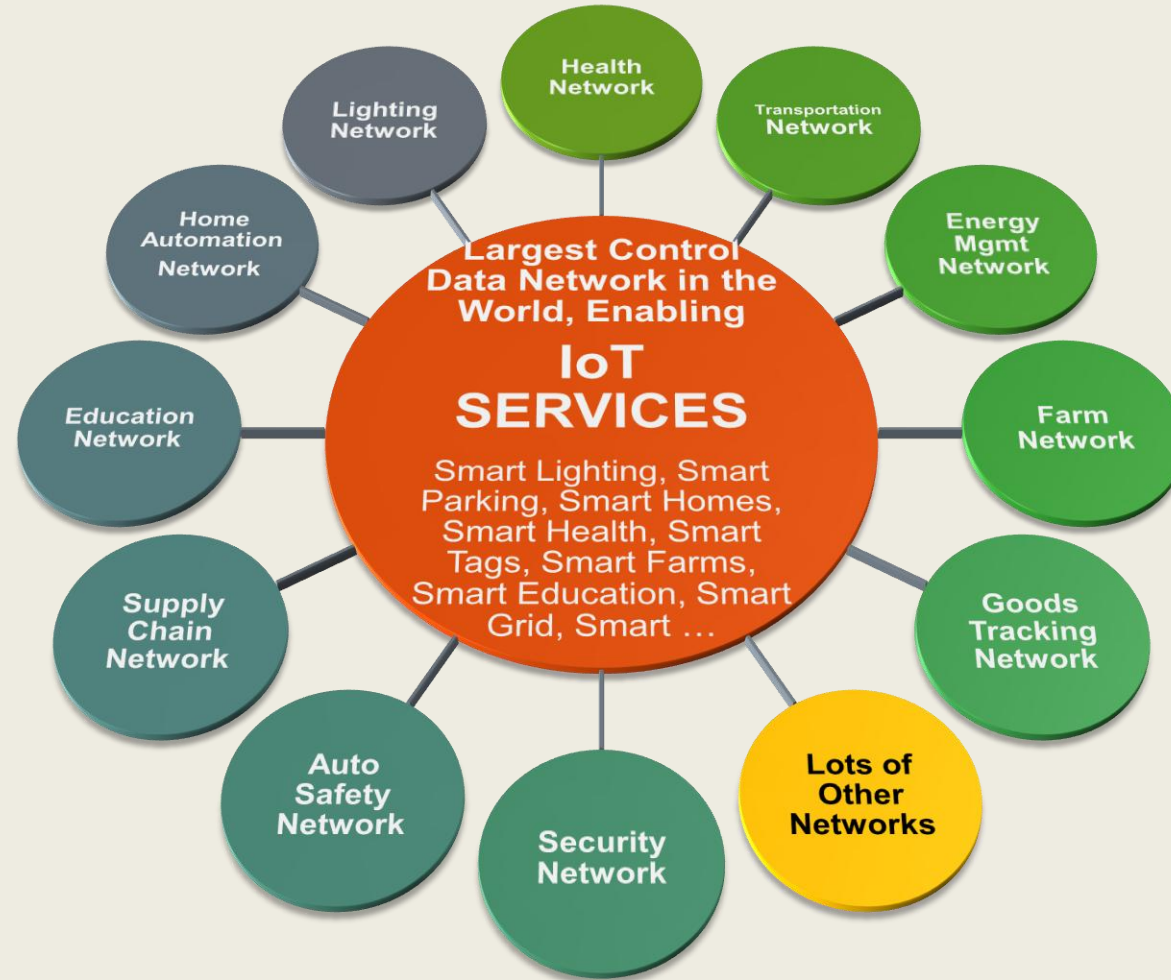

Rolling out the IoT is like rolling out the largest control data network in the world

Trends in Embedded Product Design



Internet of Things (IoT) is driving massive expansion of smart, connected devices requiring maximum energy efficiency and small form factors enabled by MCUs with:

- **Ultra-small package footprints**
 - Miniaturized PCB area for space-constrained applications; portable consumer devices, remote sensor nodes, motor control and healthcare monitoring
- **Increased energy efficiency**
 - Rapid MCU wake-up, process and return-to-sleep profiles. Flexible low-power modes & peripherals for extracting maximum system life from the smallest power budgets
- **Advanced performance, feature integration and software support**
 - 32-bit processing power to support complex algorithms, connectivity stacks and HMIs
 - Rich connectivity and analog capabilities for precision sensing, communication and control

Kinetis KL03 CSP – The World’s Smallest ARM-based MCU



> 20,000 KL03 20WLSCPs fit
inside a golf ball!

- **Miniature Package Size**
 - 1.6 x 2.0 mm² – 35% smaller and 60% more GPIO than the competition
 - Ideal for space-constrained applications where cost or environmental factors prevent use of larger QFN/LQFP/BGA packages – IoT enabled consumer devices, remote sensing nodes, wearable devices, ingestible medical sensors
 - Newest member of the Kinetis ‘Mini’ portfolio – >10 million L & K Series CSP MCUs shipped to date with high performance/feature integration and ultra low power capabilities
- **Energy Efficiency & Feature Integration**
 - Cortex-M0+ core delivers CoreMark/mA – 2-8 x improvement vs. 8/16-bit MCUs
 - Multiple low power RUN, WAIT & STOP modes – from 41µA@MHz Very-Low-Power-Run mode, to 77nA Very Low-Leakage STOP 0 mode with 16byte register file retention
 - High accuracy ADC voltage reference, 1Mbit/s IIC, low power UART
 - 8KB ROM bootloader – in-system flash programming via I2C, LPUART or SPI. S/ware flexibility during development, manufacture or in-field deployment
- **Scalability & Enablement**
 - More than 200 Kinetis L Series MCUs from 8-256kB, 16-121pin with precision mixed-signal, connectivity and HMI peripheral options. Starting from \$0.50
 - Low cost FRDM-KL03Z development board, complimentary Kinetis Design Studio IDE (no code size limit) & Software Development Kit (SDK). Broad ARM ecosystem support

Kinetis L Series KL03 Block Diagram

Core/System

- ARM Cortex-M0+ @ 48MHz

Memory

- 8/16/32KB Flash,
- 2KB SRAM
- 8KB ROM with build-in Bootloader
- 16 bytes register file retention

Communications

- Low-power UART, SPI
- High Speed I2C up to 1Mbps

Analog

- 12-bit ADC with internal voltage reference
- CMP with 6-bit DAC
- Embedded 1.2V voltage reference for analog peripherals

Timers

- 2x2ch Timer/PWM
- RTC
- Low Power Timer

Other

- Up to 22 I/Os
- 3 high-drive I/Os (20mA)
- 1.71V-3.6V
- -40°C to 105 °C for QFN; -40°C to 85 °C for WLCSP

Packages

- 16/24QFN, 20WLCSP

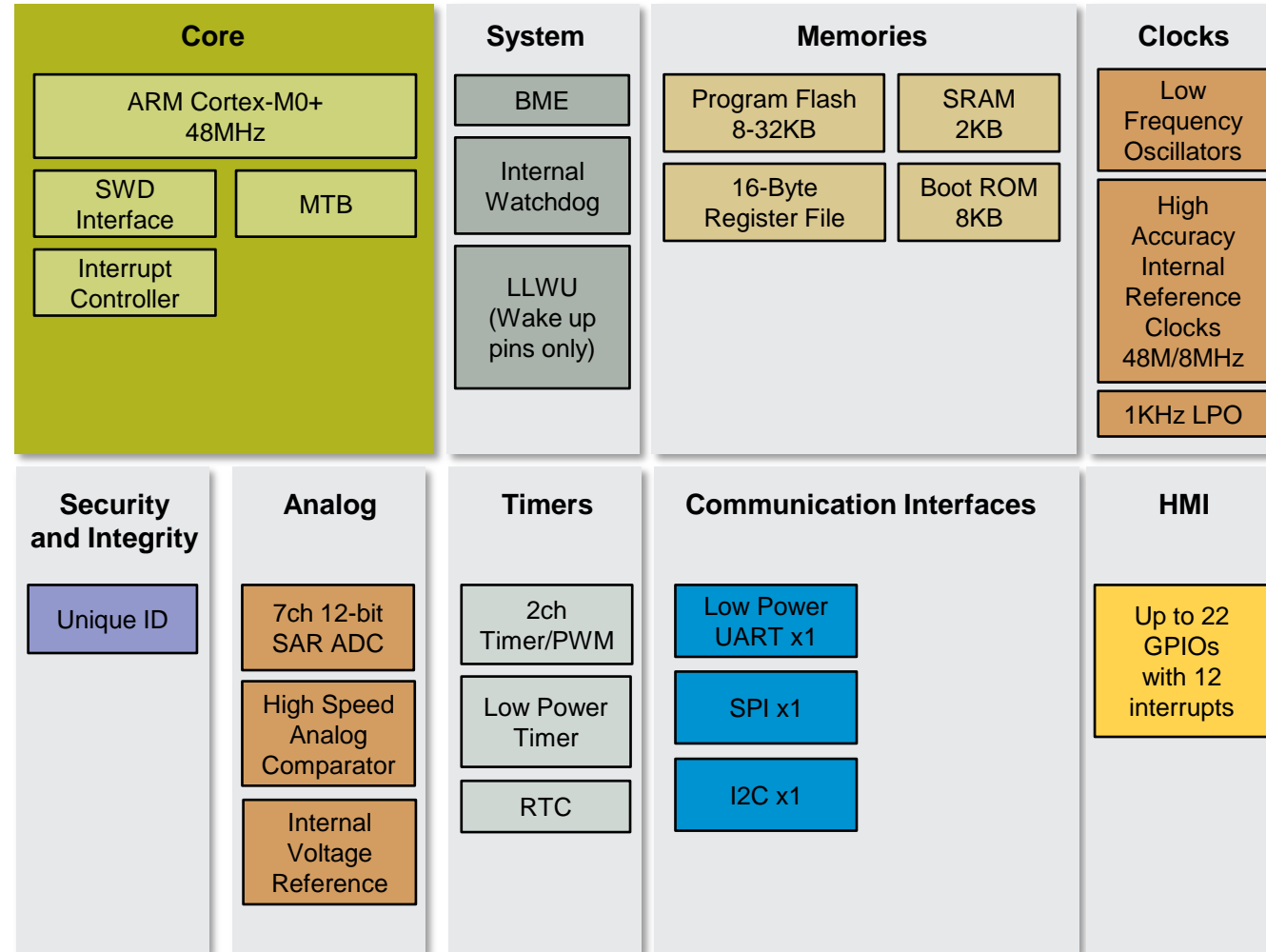

□ Standard Feature □ Optional Feature

Kinetis MCU WLCSP Roadmap

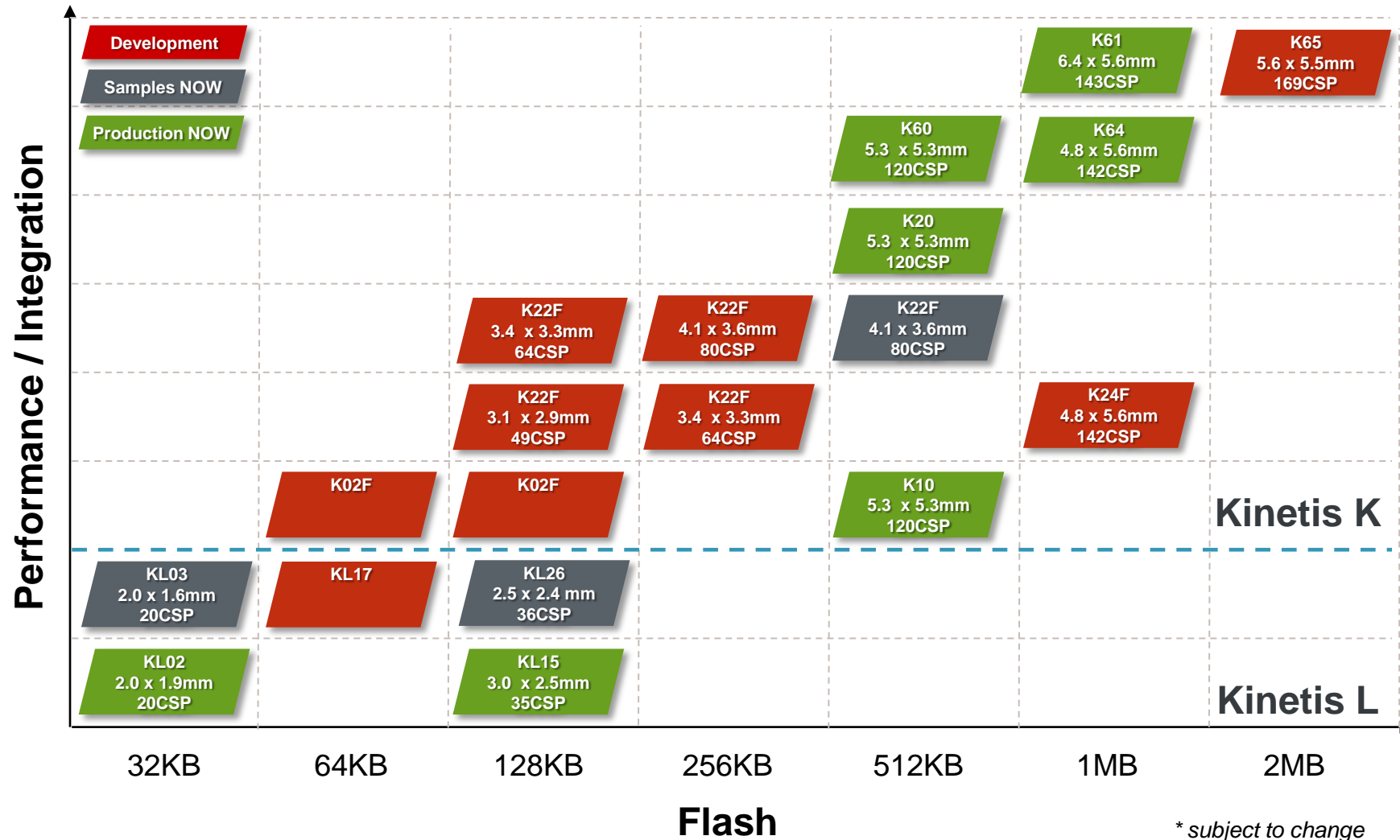



MCU Software Environment



Confidential and Proprietary

Freescale, the Freescale logo, ARBot, C-E, CodeTEST, CodeWarrior, CodeFire, CodeFree, C-Ware, the Energy Efficient Solutions logo, Kinetic, i68kMOT, PES, PowerQUICC, Processor Expert, QorIQ, Qorliva, SafeAssure, the SafeAssure logo, StarCore, Symphony and Vorteo are trademarks of Freescale Semiconductor, Inc., Reg. U.S. Pat. & Tm. Off. Airbat, Be@t, Be@t!, CoreNet, Flexis, Layerscape, MagiW, MKC, Platform in a Package, QorIQ Gateway, QorIQ Engine, Ready Plug, SMARTMOS, Tower, TriadLink, UMEMI, Vybrid and Xtrinsic are trademarks of Freescale Semiconductor, Inc. All other product or service names are the property of their respective owners. © 2014 Freescale Semiconductor, Inc.



Growing Importance of Enablement

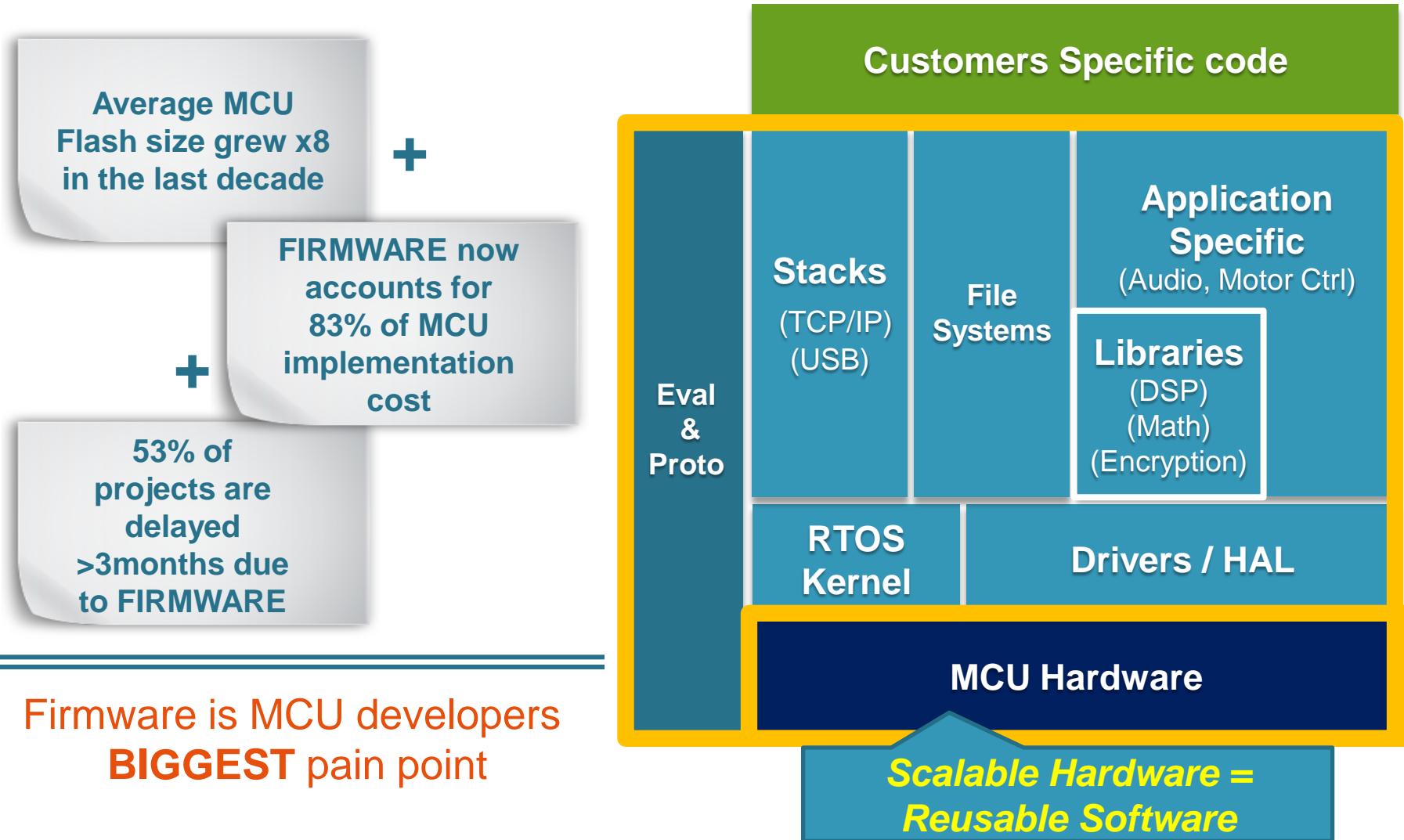

Firmware is MCU developers **BIGGEST** pain point

Freescal Microcontroller Enablement Bundle

Solution Advisor Part Selector



Find best-fit processors and tools with web-based interactive product selector

Development Platforms



Low cost hardware platforms for prototyping application development

Development Tools



Visual and automated framework to accelerate development time, deliver software components

Development Software

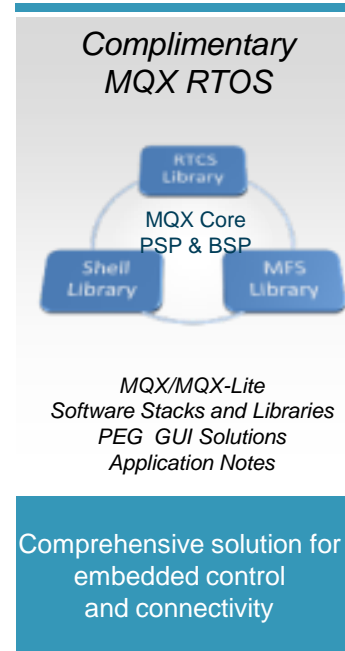

Comprehensive solution for embedded control and connectivity

Online Enablement



Cloud enablement through freely available online design tools, communities, part selectors





Kinetis Design Studio



No-cost integrated development environment (IDE) for Kinetis MCUs



Eclipse and GCC-based IDE for C/C++ editing, compiling and debugging

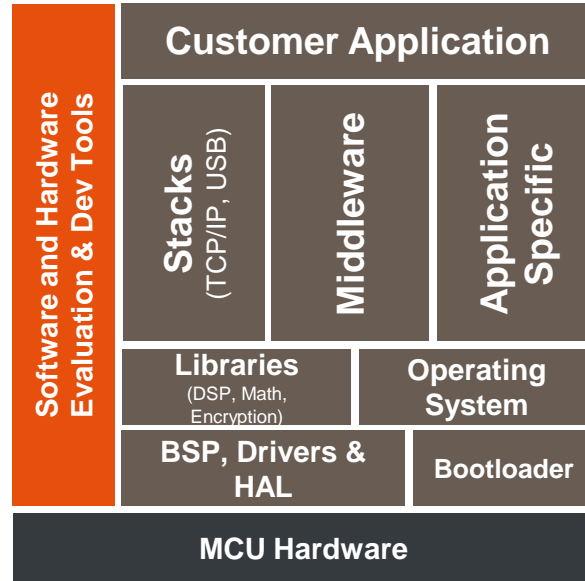

Product Features

- A free of charge and unlimited IDE for Kinetis MCUs
- A basic IDE that offers robust editing, compiling and debugging
- Based on Eclipse, GCC, GDB and other open-source technologies
- Includes Processor Expert (PEX) with Kinetis SDK integration
 - Supports all existing Kinetis devices via PEX and new project wizard
 - All new Kinetis devices will also feature the Kinetis SDK with PEX configurability
- Host operating systems:
 - Windows 7/8 (32 and 64-bit)
 - Linux (Ubuntu, Redhat, Centos)
 - Mac OS X (coming Q3 2014)
- Support for SEGGER, P&E and Open SDA/CMSIS-DAP debugger targets
- Support for Eclipse plug-ins including RTOS-awareness (i.e. MQX, FreeRTOS)





Kinetis Software Development Kit (SDK)



A complete software framework for developing applications across all Kinetis MCUs



HAL, peripheral drivers, libraries, middleware, utilities, and usage examples; delivered in C source

Product Features

- Open source hardware abstraction layer (HAL) provides APIs for all Kinetis hardware resources
- BSD-licensed set of peripheral drivers with easy-to-use C-language APIs
- Comprehensive HAL and driver usage examples and sample applications for RTOS and bare-metal
- GUI configurable projects and peripheral drivers using Processor Expert
- CMSIS-CORE compatible startup plus CMSIS-DSP library and examples
- RTOS Abstraction Layer (OSA) with support for Freescale MQX, FreeRTOS, Micrium uC/OS, and bare-metal
- Integrates new Freescale unified USB stack, open source TCP/IP stack (lwIP), open source FAT file system, encryption math/DSP libraries, and more and
- Support for multiple toolchains including GNU GCC, IAR, Keil, and Kinetis Design Studio

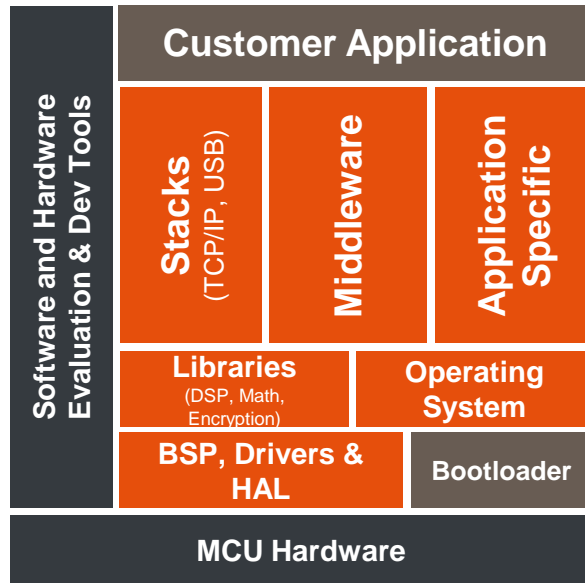

Processor Expert

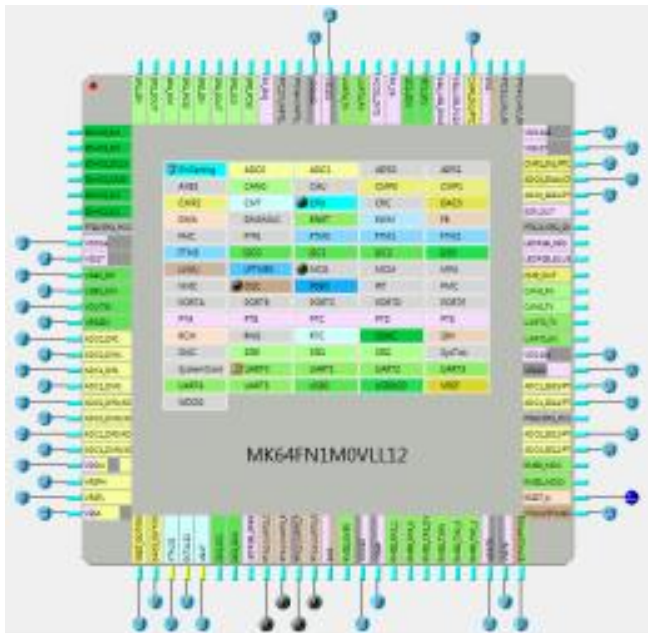

- Processor Expert (PEX) is a complimentary Eclipse plug-in tool for software configuration
- Provides a time-saving option for software configuration through a graphical user interface (GUI)
- Board configuration and driver tuning capabilities include:
 - Optional generation of low-level device initialization code for post-reset configuration
 - Pin muxing tools to generate pin muxing functions
 - Components based on Kinetis SDK drivers
 - Users configure the SoC and Peripherals in a GUI
 - PEX creates the configuration data structures for driver config and init

Kinetis Design Studio Projects

- **'Bare' Projects**
 - 'minimal' and expert start point
 - Startup code, linker file
- **Processor Expert Projects**
 - Init, peripheral and device components
 - All Kinetis Devices supported!
- **Kinetis SDK Projects**
 - Starting point with bare Kinetis SDK
 - KSDK beta with K64F
- **Kinetis SDK + Processor Expert**
 - Graphical configuration of SDK
 - SDK Components

Bare and minimal projects

Fastest and easiest way to create Kinetis applications!

For the SDK Experts

Easiest and fastest way to use the Kinetis SDK

Additional Resources



Community

<https://community.freescale.com/community/kinetis-design-studio>



Web

www.freescale.com/kds



Kinetis K Series MCUs

Performance and Integration



Confidential and Proprietary

Freescale, the Freescale logo, ARBot, C-E, CodeTEST, CodeWarrior, CodeFusion, CodeFree, C-Ware, the Energy Efficient Solutions logo, Kinetis, iM68K07, PEG, PowerQUICC, Processor Expert, QorIQ, Qoriva, SafeAssure, the SafeAssure logo, StarCore, Symphony and Vybrid are trademarks of Freescale Semiconductor, Inc., Reg. U.S. Pat. & Tm. Off. AirStar, BeeBot, Beelink, CoreNet, Flexis, Layerscape, MagniV, MKC, Platform in a Package, QorIQ Gateway, QorIQ Engine, Ready Plug, SMARTMOS, Tower, TriadLink, UMEMR, Vybrid and Xtrinsic are trademarks of Freescale Semiconductor, Inc. All other product or service names are the property of their respective owners. © 2014 Freescale Semiconductor, Inc.



Kinetis K Series MCU Portfolio

ARM Cortex-M4 solutions for a wide range of embedded applications

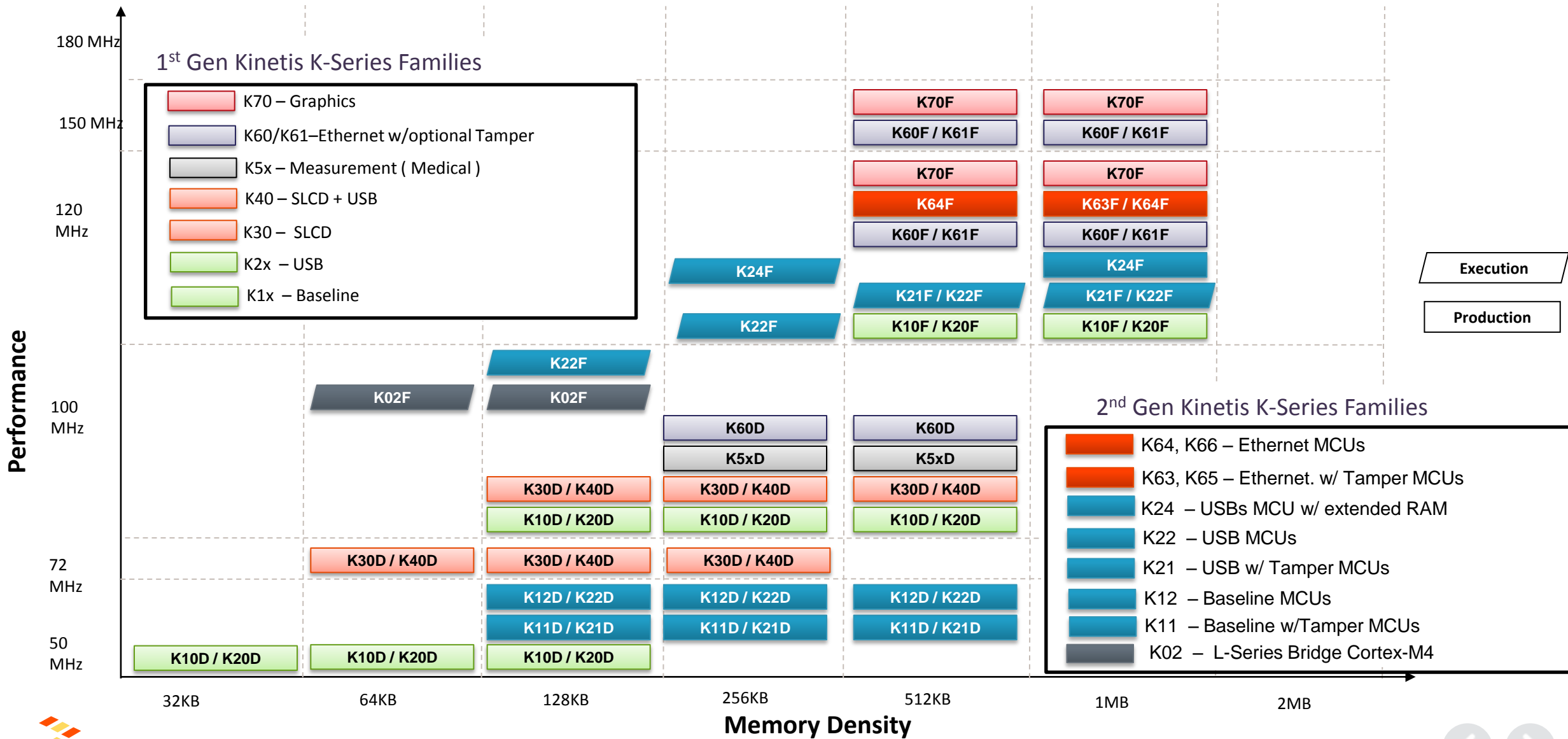



Kinetis L Series MCUs

The world's most energy-efficient ARM-based MCUs



Confidential and Proprietary

Freescale, the Freescale logo, ARMv6, C-S, CodeTEST, CodeWarrior, ColdFire, ColdFire+, C-Ware, the Energy Efficient Solutions logo, Kinetis, iM640T, PEG, PowerQUICC, Processor Expert, QorIQ, Qorlva, SafeAssure, the SafeAssure logo, StarCore, Symphony and Vybrid are trademarks of Freescale Semiconductor, Inc., Reg. U.S. Pat. & Tm. Off. AirStar, Be@t, Be@t!, CoreNet, Flexis, Layerscape, MagniV, MKC, Platform in a Package, QorIQ Gateway, QorIQ Engine, Ready Plug, SMARTMOS, Tower, TriadLink, UMEMR, Vybrid and Xtrinsic are trademarks of Freescale Semiconductor, Inc. All other product or service names are the property of their respective owners. © 2014 Freescale Semiconductor, Inc.



Kinetis L Series MCUs

*Design Made
Simple.*

Ultra-low Power

Architected for power efficiency, the Kinetis L series takes advantage of ARM's ultra-low-power Cortex-M0+ core and features peripherals that help you optimize power consumption.

Super Simple

It's 32-bit functionality with 8-bit ease-of-use. Built on the new ARM Cortex-M0+ core (the smallest, lowest-power ARM core), the L series simplifies development with an upward migration path to Kinetis K and X series, software reuse and flexible power optimization. And, with a comprehensive enablement bundle including CodeWarrior IDE, MQX RTOS and the ARM support ecosystem, development is simple.

Leading Scalability and Integration

Expanding on well-known features of the Kinetis platform with leading scalability, best-in-class integration with rich analog features and low-power connectivity, the L series redefines entry-level.

Benefits of Moving from 8/16-bit Architecture to a 32-bit Architecture Built on the ARM Cortex-M0+ Core

8/16-bit	32-bit ARM Cortex-M0+
<p>Performance</p> <ul style="list-style-type: none"> • Older, slower architectures and technology • Increased code size/complexity when performing complex math operations 	<p>Performance</p> <ul style="list-style-type: none"> • 2x to 40x more than 8/16-bit, 9% more than Cortex-M0 • Fast 32-bit math processing • Fast single-cycle access to I/O
<p>Energy efficiency</p> <ul style="list-style-type: none"> • Low energy efficiency 	<p>Energy efficiency</p> <ul style="list-style-type: none"> • >2x CoreMark/mA than closest 8/16-bit MCU, +30%/ CM0
<p>Low cost</p> <ul style="list-style-type: none"> • 6-35 kbytes • Variable code density 	<p>Low cost</p> <ul style="list-style-type: none"> • 12-35 kbytes • Excellent code density
<p>Ease of development</p> <ul style="list-style-type: none"> • Limited addressable memory • Simplistic interrupt controllers • Limited scalability (MHz, flash, features) • Limited ecosystem support 	<p>Ease of development</p> <ul style="list-style-type: none"> • Linear 4 GB address space—no need for paging • Full-featured interrupt controller—simpler s/w architecture • Huge scalability—h/w and s/w reuse across end products • Huge ARM ecosystem—off-the-shelf software/tools/training • Micro Trace Buffer—lightweight, non-intrusive trace

Freescale and ARM collaborated to develop a revolutionary processor that **extends battery life** by improving energy efficiency, **enables advanced peripherals and software** by increasing processing performance and **reduces system cost** by improving code density.

Freescale's MCU experts helped define key **'8-bit-like' processor features** including ease of use.

Kinetis L Series MCUs Feature Overview

Common Features	Optional Features														
System	Family	Flash	SRAM	Pin Count	Key Features										
Cortex-M0+ Core, 48/72 MHz					USB	SLCD	DMA	RTC	ADC	DAC	I2S	TSI	ROM	Vref	Secure/BB
Multi-Low-Power Modes and Peripherals, Low-Power Boot, Clock Gating	KL46	128-256 KB	16-32 KB	64-121	OTG	Y	Y	Y	16-bit	12-bit	Y	Y			
1.71-3.6 V, -40 °C to 105 °C [1]	KL43	128-256 KB	16-32 KB	48-64	Slave	Y	Y	Y	16-bit	12-bit	Y		Y	Y	
Memory	KL36	64-256 KB	8-32 KB	64-121		Y	Y	Y	16-bit	12-bit	Y	Y			
90 nm TFS Flash, SRAM	KL34	64 KB	8 KB	64-100		Y	Y	Y	12-bit						
Internal Memory Security/Protection	KL33	16-256 KB	2-32 KB	48-64		Y	Y	Y	16-bit	12-bit	Y		Y	Y	
Analog Peripherals	KL28	256-512 KB	128 KB	64-121	OTG		Y	Y	16-bit	12-bit	Y	Y	Y	Y	Y
12/16-bit ADC, 12-bit DAC	KL27	256-512 KB	128 KB	64-121	OTG		Y	Y	16-bit	12-bit	Y	Y	Y	Y	Y
High-Speed Comparator	KL26	32-256 KB	4-32 KB	32-121	OTG		Y	Y	16-bit	12-bit	Y	Y			
Serial Interfaces	KL25	32-128 KB	4-16 KB	32-80	OTG		Y	Y	16-bit	12-bit		Y			
UART (Including 1 LPUART)	KL24	32-64 KB	4-8 KB	32-80	OTG		Y	Y	16-bit	12-bit					
SPI, I ² C	KL23	16-256 KB	2-32 KB	32-64	Slave		Y	Y	16-bit	12-bit	Y		Y	Y	
Timers	KL16	32-256 KB	4-32 KB	32-64			Y	Y	16-bit	12-bit	Y	Y			
Real-Time Clock [2]	KL15	32-128 KB	4-16 KB	32-80			Y	Y	16-bit	12-bit		Y			
16-bit Low-Power TPMs (GP Timer/PWM)	KL14	32-64KB	4-8 KB	32-80			Y	Y	16-bit	12-bit					
Low-Power Timers	KL13	16-256 KB	2-32 KB	32-64			Y	Y	16-bit	12-bit	Y		Y	Y	
32-bit Periodic Interrupt Timer	KL05	8-32 KB	1-4 KB	24-48			Y	Y	12-bit	12-bit		Y			
	KL04	8-32 KB	1-4 KB	24-48			Y	Y	12-bit						
	KL03	8-32 KB	1-2 KB	16-24				Y	12-bit				Y	Y	
	KL02	8-32 KB	1-4 KB	16-32					12-bit						



Kinetis L Series MCUs: World's Most Energy-Efficient ARM-based MCUs

- **Ultra-efficient ARM Cortex-M0+ core**
 - Very low power run at 40 uA/MHz
- **Flexible ultra-low-power modes**
 - Deep sleep down to 150 nA
- **Energy-saving architecture**
 - DMA, UART, ADC, Timers plus other peripherals functional in deep sleep

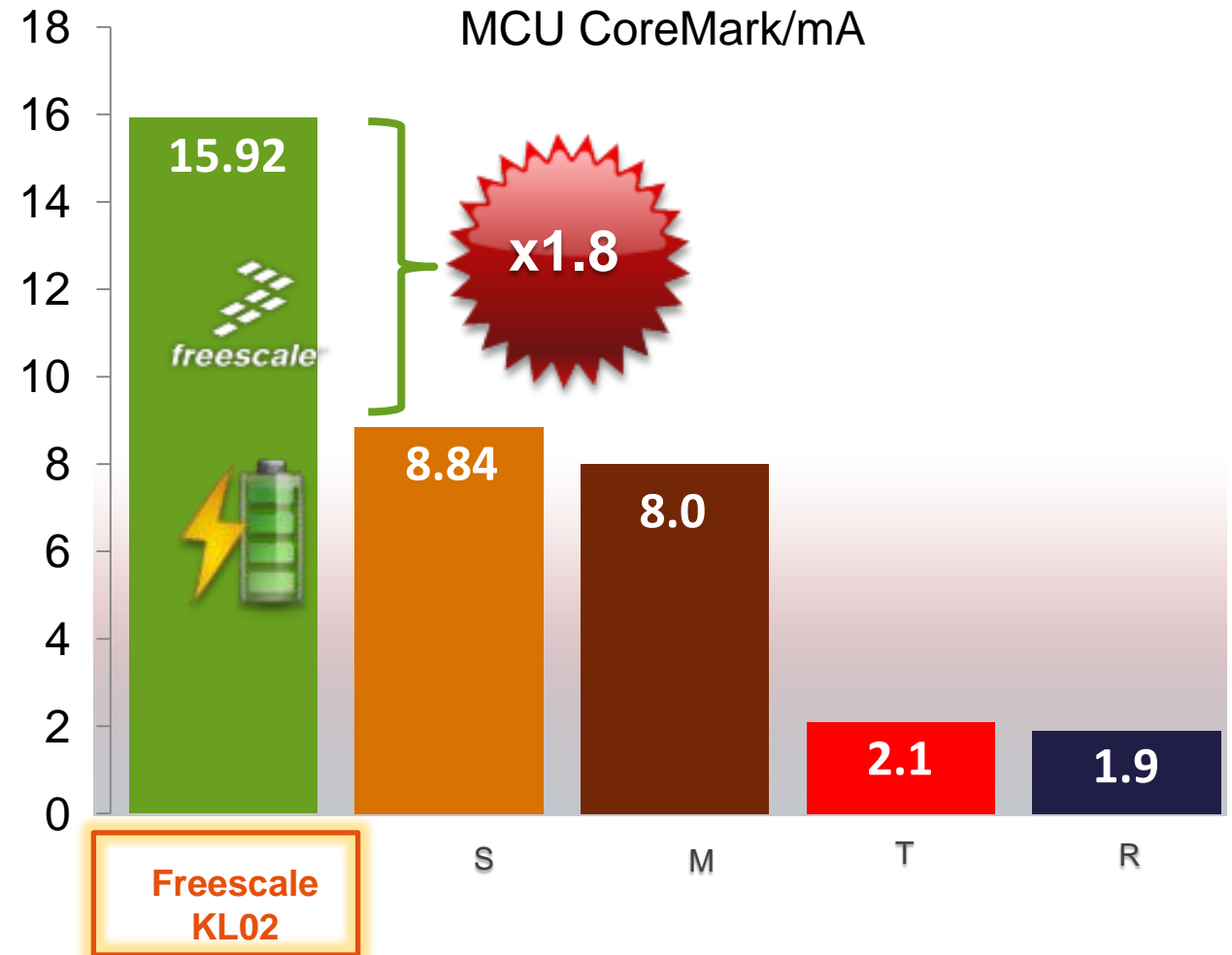
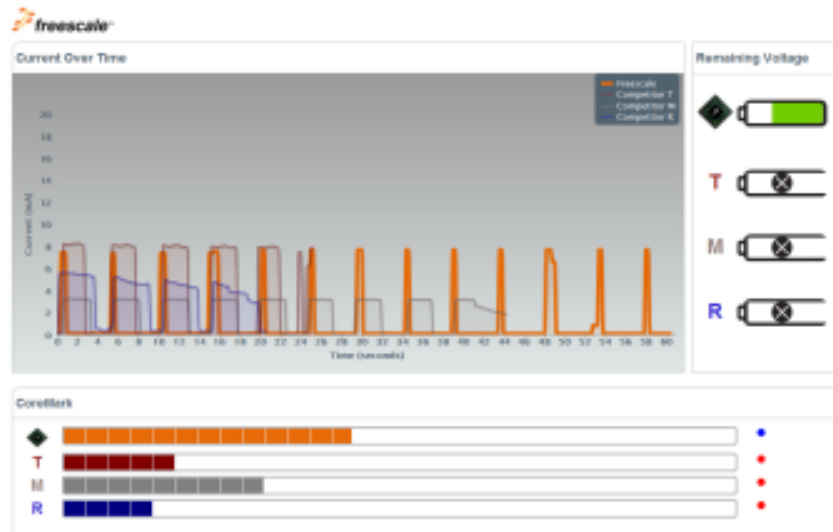



Breakthrough Power Efficiency

	<i>Kinetis Power Modes</i>	<i>Recovery Time</i>	<i>KL26 Measured I_{dd} @ 3 V and 25 C</i>
Leading Dynamic Power	RUN	-	79 uA/MHz*
Innovative low-power process technology (C90TFS)	VLPR	-	39 uA/MHz**
Low-power-focused platform design	WAIT	1.6 us	2.7 mA @ 48 MHz
Next-generation Cortex-M0+ core	VLPW	1.6 us	110 uA @ 4 MHz
Asynchronous DMA Wake-Up (ADMA)	STOP	1.3 us	301 uA
Energy-saving peripherals are operational with ADMA feature that can wake-up DMA to perform transfer and return to current mode when complete	VLPS	4.2 us	2.3 uA
Low-Leakage Wake-Up Unit	LLS	4.3 us	1.7 uA
Enables complete shut-down of core logic, including AWIC, further reducing leakage currents in all low power modes	VLLS3	39 us	1.3 uA
Supports 8 external input pins and 8 internal modules as wakeup sources, extends the low power wake-up capability of some internal peripherals to all power modes	VLLS1	91 us	700 nA
Wake-up inputs are activated in LLS or VLLS modes.	VLLS0	91 us	139 nA /310 nA

* Compute Operation enabled: 4.0mA @ 48MHz core / 24MHz bus)

** Compute Operation enabled: 156uA @ 4MHz core / 1MHz bus)





Kinetis E Series MCUs

5V Vdd, EMC Robustness



Confidential and Proprietary

Freescale, the Freescale logo, ARBot, C-E, CodeTEST, CodeWarrior, CodeFis, CodeFis+, C-Ware, the Energy Efficient Solutions logo, Kinetic, iMbedGET, PEG, PowerQUICC, Processor Expert, QorIQ, Qorlva, SafeAssure, the SafeAssure logo, StarCore, Symphony and VortiCo are trademarks of Freescale Semiconductor, Inc., Reg. U.S. Pat. & Tm. Off. Airbat, Beibit, Beiblock, CoreNet, Flexis, Layerscape, MagniV, MKC, Platform in a Package, QorIQ Gateway, QorIQ Engine, Ready Plug, SMARTMOS, Tower, TriadLink, UMEMR, Vybrid and Xtrinsic are trademarks of Freescale Semiconductor, Inc. All other product or service names are the property of their respective owners. © 2014 Freescale Semiconductor, Inc.



Kinetis E Series MCUs

***Strong Robustness
High Efficiency
Low Cost***

Strong Robustness

EMC/ESD design technology ensure strong noise immunity performance

High Efficiency

Cortex-M0+ core up to 48MHz and 40x more than 8/16-bit MCUs

Low Cost

Optimized for cost-sensitive applications offering low pin count option

Achieve Reliability with Kinetis E Series MCUs

1. Most robust portfolio based on ARM Cortex-M0+ core

- **Proven passing EFT(IEC61000-4-4) / PESD(IEC61000-4-2) tests**
- IEC60730 Class B Safety S/W routines certified by VDE
- 5V operation provides better noise immunity
- Lower EMI noise than 8/16bit competition

2. 3x Higher efficiency than 8/16 bit solutions

- **3x Coremark/ MHz with 15% better code density**
- One cycle GPIO – (5 x better than nearest competitor)

3. Design made easier

- **Widely available ARM & Freescale Tools/ SW ecosystem**
- Open up your hiring options – ARM talent widely available
- Pin compatible and Peripheral reused within Kinetis-E and S08P families
- Freely available ESD/ EMC verification support
- Platform SDK availability

Kinetis E Series MCUs: Master Block Diagram

Core

Cortex M0+ @48MHz

Memory

128K Flash, 16K RAM, 256B EE

Communications

SCI(LIN)x3, SPIx2, IICx2, msCAN

Analog

12 bit ADC, ACMPx2

Timers

16bit FlexTimerx3, PWT,

16bit RTC, 32bit PIT

Temp

-40~105°C operation

Packages

80LQFP(0.65mm pitch);

64QFP (0.8mm pitch);

64LQFP(0.5mm pitch);

44LQFP (0.8mm pitch);

32LQFP (0.8mm pitch);

24QFN(0.5mm pitch);

20SOIC(1.27mm pitch);

16TSSOP(0.65mm pitch)

Others

Pin compatible within KEx on same package;

KBIx2

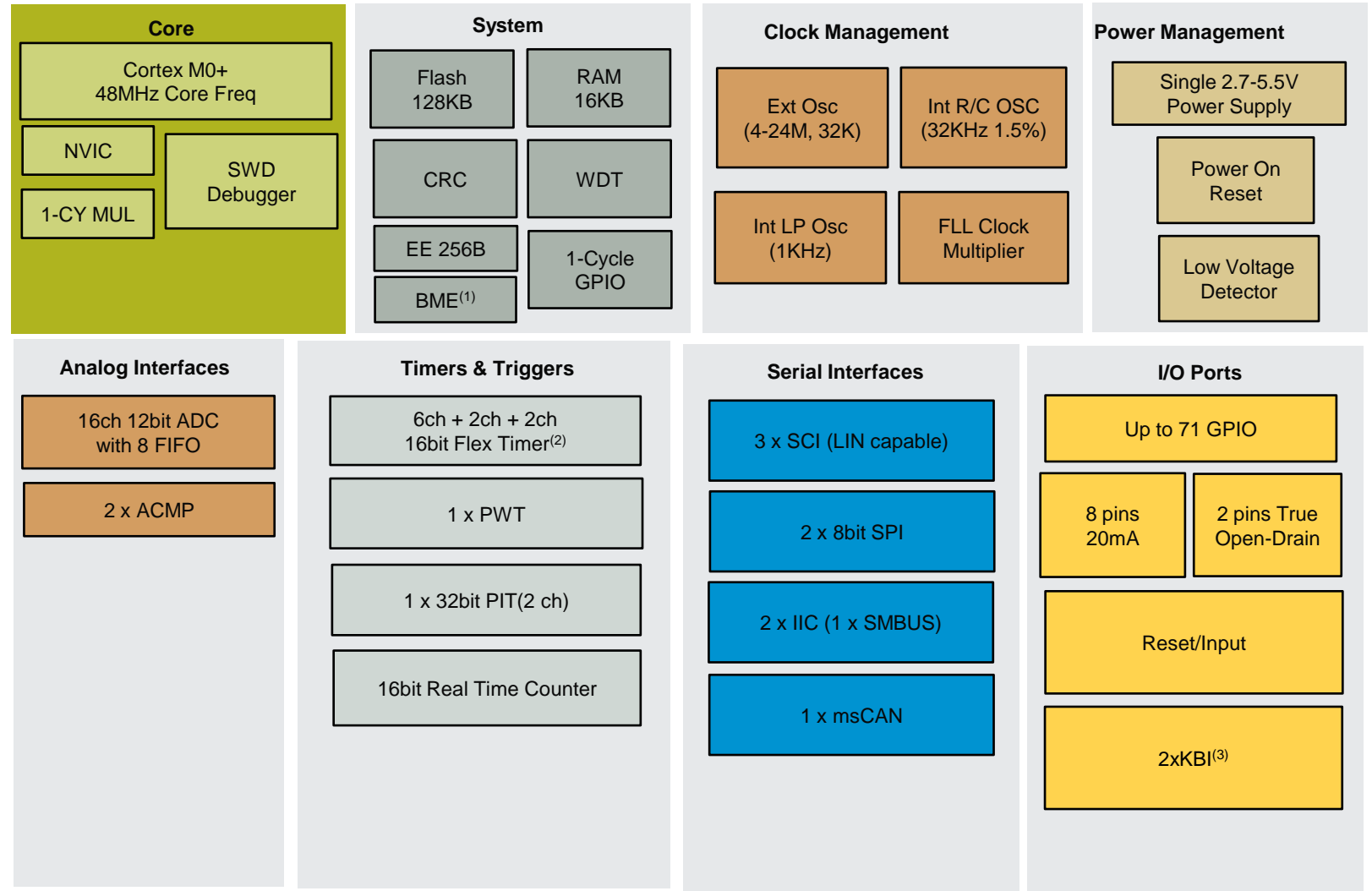

(1) Support bit operation in RAM

(2) Faster timer running 2 x core clock

(3) 32ch KBI module



Kinetis E Series: MCU Families

Common Features	Optional Features									
System	Family	Speed	Flash	SRAM	Key Features					
ARM Cortex-M0+ Core, 48MHz [1]					CAN	Seg. LCD	PWT	Fast Timer	ADC	TSI
Multiple power modes, Clock Gating, 2.7V – 5.5V	KE06Z	48MHz	64-128KB	8-16KB	✓		✓	✓	12-bit	
Operating Temp: -40 to 105°C										
Clock Management	KE04Z128	48MHz	128KB	16KB			✓	✓	12-bit	
External OSC, 4~20MHz, 32KHz										
Internal OSC, 32KHz, 1KHz	KE04Z64	48MHz	64KB	8KB			✓	✓	12-bit	
Analog Peripherals										
12-Bit ADC	KE04Z8	48MHz	8KB	1KB			✓	✓	12-bit	
Analog Comparators										
Serial Interfaces	KE02Z	20MHz/ 40MHz	16-64KB	2-4KB					12-bit	
SCI										
SPI, IIC										
Timers										
Real Time Clock										
16bit Flex timers										
32bit Periodic Interrupt Timer										

[1] 20MHz/40MHz for KE02



Kinetis V Series MCUs

Motor Control & Power Conversion MCUs



Confidential and Proprietary

Freescale, the Freescale logo, ARBot, C-E, CodeTEST, CodeWarrior, ColdFire, ColdFire+, C-Ware, the Energy Efficient Solutions logo, Kinetis, iMCM07, PEG, PowerQUICC, Processor Expert, QorIQ, Qorlva, SafeAssure, the SafeAssure logo, StarCore, Symphony and Vybrid are trademarks of Freescale Semiconductor, Inc., Reg. U.S. Pat. & Tm. Off. Altera, Altera, Altera, CoreNet, Flexio, Layerscape, MagniV, MKC, Platform in a Package, QorIQ Gateway, QorIQ Engine, Ready Fly, SMARTMOS, Tower, TriadLink, UMEMI, Vybrid and Xilinx are trademarks of Freescale Semiconductor, Inc. All other product or service names are the property of their respective owners. © 2014 Freescale Semiconductor, Inc.



Kinetis V Series MCUs

Motor & Power Control

Full Kinetis portfolio compatibility targeting low cost, stand alone motor control, to high performance digital power conversion

Optimized for processing efficiency with performance ranging from 75MHz to beyond 200MHz

ARM architecture with best in class, high speed capture and control peripherals for motor control and power management applications

Enablement and tools built around reducing customer development time and cost, whilst increasing ease of use.

Kinetis V Series MCUs: Target Applications

Motor Control

- Sensored BLDC / PMSM
 - High Dynamic Control
- Sensored ACIM
- Sensorless VOC
 - PMSM/BLDC
 - High Dynamic Control
 - Low Dynamic Control
- Sensorless ACIM



Digital Power Conversion

- Solar Inverters
 - Grid-Tied
 - Non Grid Tied
- Power factor correction
- Switch Mode Power Supplies
 - AC/DC
 - DC/DC
- UPS
 - On-Line
 - Offline
- Inductive cooking
 - Multi cook plate

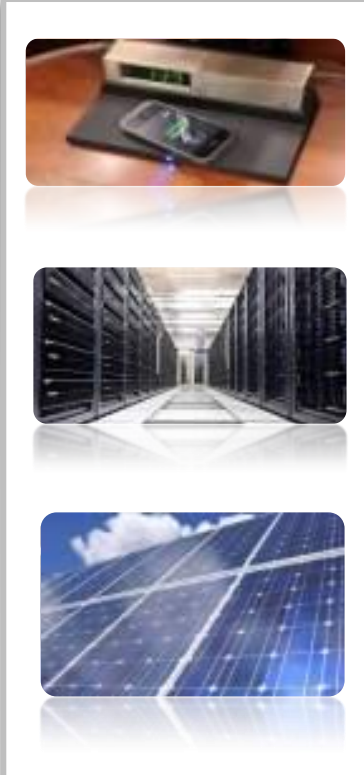

Kinetis V Series Portfolio Overview

Common Features	Optional Features												
System	Family	Core / MHz	Flash	SRAM	ADC	FlexTimers	eFlexPWM	DAC	CAN				
ARM Cortex-M0+ core (H/w DIV&SQRT) ARM Cortex-M4 core (DSP + FPU)	KV4x Family: Advanced Control Systems												
Multiple low-power modes Power Supply 1.71V - 3.6V	KV46	Cortex-M4 w FPU 150MHz	128- 256KB	24- 32KB	2x 12-bit, up to 4.1 Msps	Up to 18ch	Up to 12ch (NanoEdge)	1	2				
Operating Temp: -40 to 105°C			KV45	128- 256KB	24- 32KB	2x 12-bit , up to 1.9 Msps	Up to 18ch	Up to 12ch	-	Up to 2			
Memory				KV44	64- 128KB	16- 24KB	2x 12-bit, up to 4.1 Msps	-	Up to 12ch (NanoEdge)	1	1		
90nm TFS Flash, SRAM					KV43	64- 128KB	16- 24KB	2x 12-bit , up to 1.9 Msps	-	Up to 12ch	-	Up to 2	
Internal Memory Security/Protection						KV40	64- 256KB	16- 32KB	2x 12-bit, up to 1.9 Msps	Up to 18ch	-	-	Up to 2
Direct Memory Access Controller							KV3x Family: High Dynamic Control Systems						
Analog	KV31	Cortex-M4 w FPU 100/120MHz	128- 512KB	24- 96KB	2x 16-bit, up to 1.2 Msps*	Up to 20ch	-	Up to 2	-				
Dual 12/16-Bit ADCs			KV30	64- 128KB	16KB	2x 16-bit, up to 1.2 Msps*	Up to 12ch	-	1	-			
12-bit DAC				KV1x Family: Low Dynamic Control Systems									
Analog Comparators	KV10	Cortex-M0+ 75MHz	16-32KB	8KB	2x 16-bit, up to 1.2 Msps*	Up to 10ch	-	1	-				
Serial Interfaces													
UART													
SPI, IIC													
Timers													
FlexTimer (1ns) / eFlexPWM (312ps)													
16-bit Low Power Timer													
Programmable Delay Block													

* 1.2Msps rate available in 12-bit mode

Kinetis V Series MCUs: 3 Phase Motor Control

Entry Level
FOC Motor Control

Integrated
Motor Control
Solutions

Scalable Mid
Range Motor
Control

High Performance
Motor Control

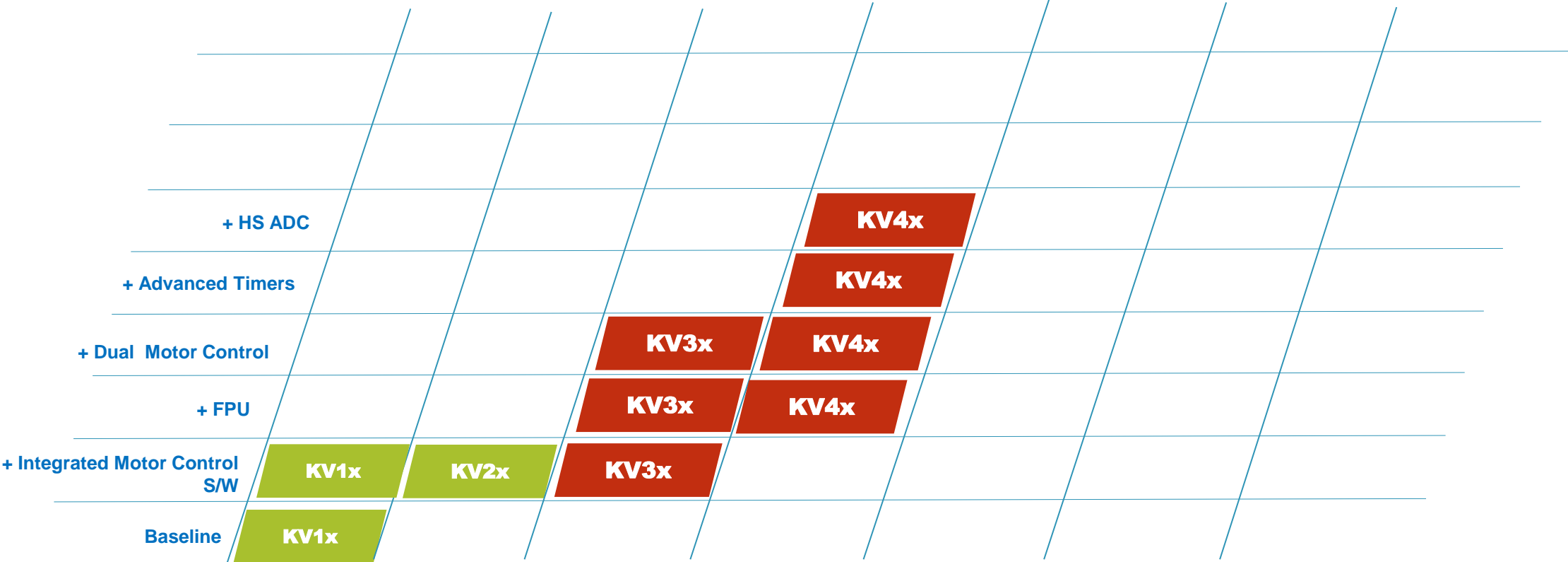

Core: ■ ARM Cortex-M0+
■ ARM Cortex-M4



Kinetis V Series MCUs: Power Conversion

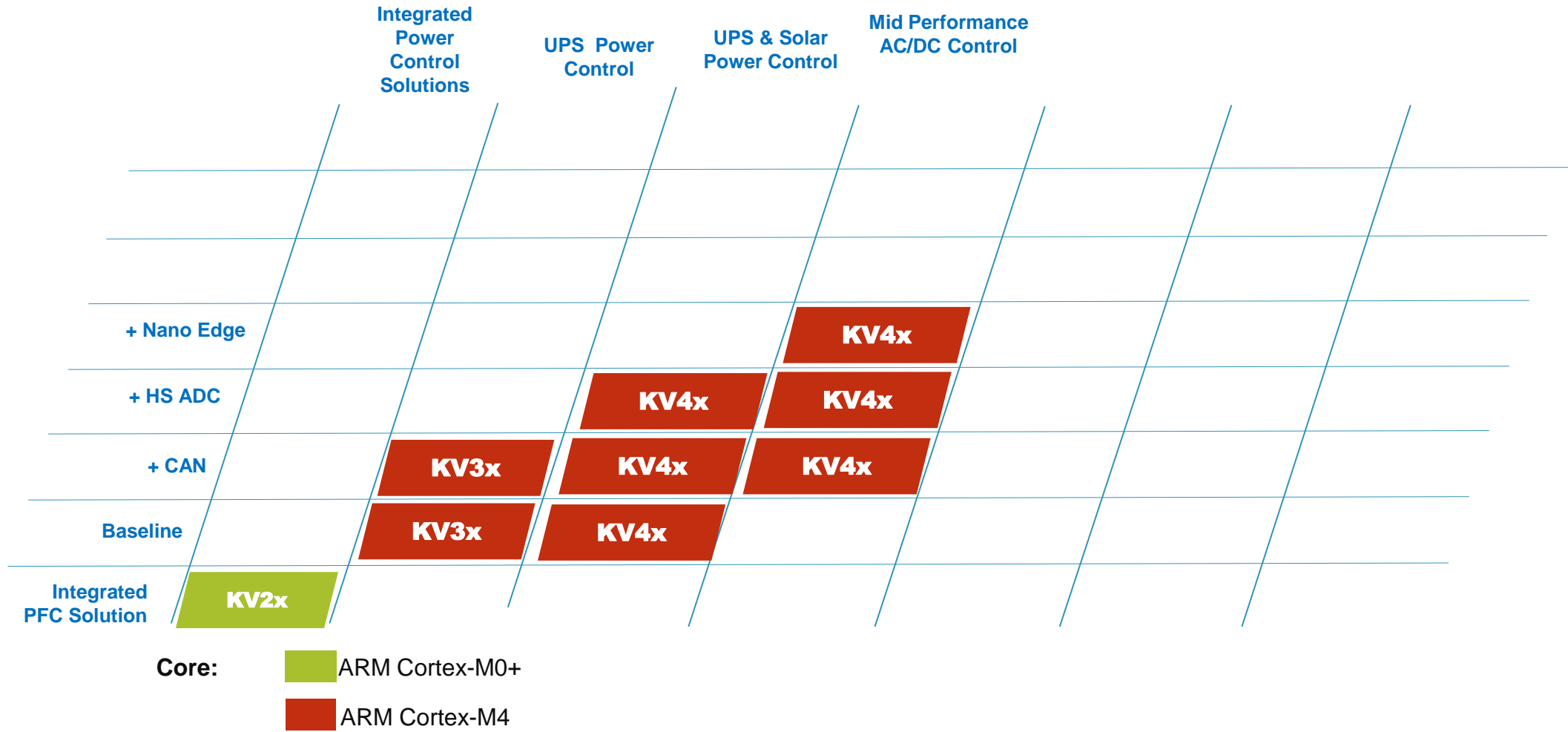

Kinetis V Series MCUs Product Roadmap

Motor & Power Control specific MCUs, Based on ARM Cortex-M with best-in-class Enablement

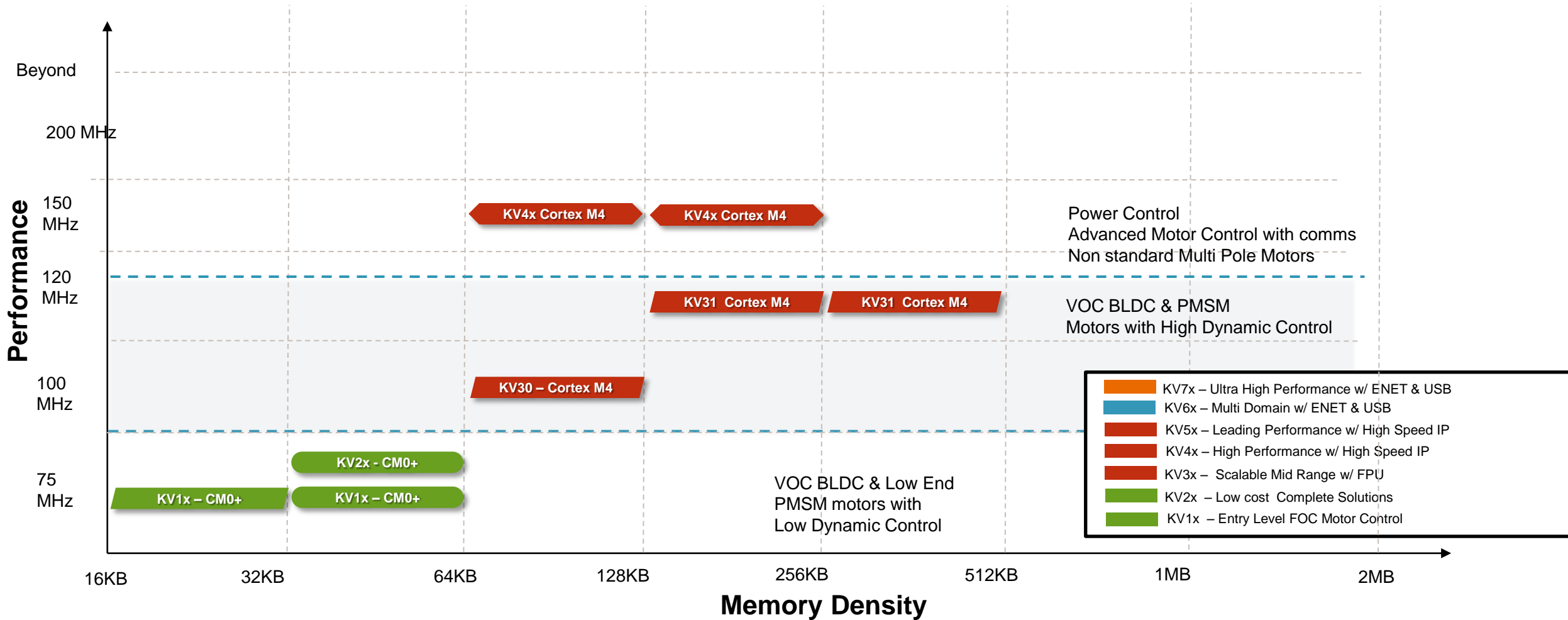

Kinetis V Series KV1x MCU: Features and Benefits

Features	Benefits
Cortex M0+ @75MHz	Fastest ARM Cortex M0+ MCU in the market. Enables advanced PMSM motor control with a small footprint, cost-effective MCU
Hardware Square Root & Divide blocks	Up to 35% performance vs. ARM Cortex-M0 based MCUs in math-intensive applications such as Sensorless FOC algorithms
2 x 16-bit ADCs with 835nS conversion times	Capture current & voltage simultaneously for the most accurate result
4-ch DMA	Reduced CPU loading, improved system performance
6-ch FlexTimer + 2 x 2-ch FlexTimer	Motor control PWM generation with integrated PFC, or integrated speed sensor decoder (incremental decoder / hall sensor)
Integrated 6-bit DAC & CMP	Fault detection against over-current and over-voltage. Reduced Bom costs
Peripheral Interconnection	ADC and ACMP interconnected with PWM and PDB for real time hardware control
Light weight peripheral and memory configuration	Enough performance for the majority of motor control applications, with the right amount of memory to fit complex motor control algorithms
Dual Watchdog	IEC60730 Compliant solution

Kinetis V Series KV4x MCU: Features and Benefits

Features	Benefits
150MHz cortex M4 core	High performance core needed for the most demanding mathematically dependant applications
128bit wide, 128Bit cache	Fast Flash access with reduced wait states
240ns conversion time ADC	The fastest ADC conversion time is the Freescale Microcontroller portfolio
eFlexPWM Timer	The most advanced and flexible timer options available simplifying development and implementation
Nano edge timer capability	First Cortex solution to feature very high resolution PWM capability enabling true power conversion
Up to 30 Timer channels	Manage multiple control loops in parallel
Dual CAN	Increased systems options, perfect for UPS applications
Quadrature Encoder	Integrated speed sensor decoder (incremental decoder / hall sensor)
Memory Protection Unit	Restricts access to key modules from within user mode enabling easier certification and greater reliability.
Floating point unit as standard across family	Increase numeric resolution for Math Intensive calculations and enabling
Dual ADC blocks with dual sample and hold	Capture current & voltage simultaneously for the most accurate result
Inter Module Crossbar w/ AND & OR interface	Configure your peripheral communication as your topology demands, simplifying pin out and reducing cross peripheral & CPU communication.
Dual Watchdog	IEC60730 Compliant Solution



Kinetis W Series MCUs

Embedded Wireless Connectivity



Confidential and Proprietary

Freescale, the Freescale logo, ARBot, C-E, CodeTEST, CodeWarrior, CodeFire, CodeFree, C-Ware, the Energy Efficient Solutions logo, Kinetics, i60640T, PEG, PowerQUICC, Processor Expert, QorIQ, QorNova, SafeAssure, the SafeAssure logo, StarCore, Symphony and VortiCo are trademarks of Freescale Semiconductor, Inc., Reg. U.S. Pat. & Tm. Off. AirStar, Be@t, Be@t!, CoreNet, Flexis, Layerscape, MagiW, MKC, Platform in a Package, QorIQ Gateway, QorIQ Engine, Ready Plug, SMARTMOS, Tower, TriadLink, UMEMI, Vybrid and Xtrinsic are trademarks of Freescale Semiconductor, Inc. All other product or service names are the property of their respective owners. © 2014 Freescale Semiconductor, Inc.



Kinetis W Series MCUs

What is Kinetis KW2x MCU?

The new Kinetis KW2x MCU is **Freescale's next-generation 2.4 GHz 802.15.4 platform**

The Kinetis KW2x MCU platform **integrates a class-leading RF transceiver, ARM Cortex-M4 core, and a robust feature set** for a reliable, secure and low-power IEEE® 802.15.4 wireless solution

Wireless protocol software is seamlessly integrated into Kinetis software development tools for rapid creation of embedded systems.



Kinetis KW2x Wireless MCU

CPU

- 50 MHz Cortex M4 CPU core
- Up to 512KB Flash & up to 64KB SRAM
- Optional (MKW21D256): 64 KB FlexNVM & 4 KB FlexRAM
- Typical current: 250 uA/Mhz run, 1.7uA RTC standby

Radio Transceiver, 2.4GHz

- IEEE-802.15.4 compliant
- 102 dBm Rx sensitivity and +10dBm Tx output power
- Peak typical current: 17mA Tx and 19mA Rx
- Dual Personal Area Network (PAN) support in hardware
 - Run two RF networks simultaneously
- Antenna diversity with automatic antenna selection

Security

- Active and passive tamper detection with RTC timestamp
- Crypto engine: DES, 3DES, AES 128-256, SHA-1, SHA-256, MD5, RNG

Software

- 802.15.4 2006 MAC
- RF4CE, ZigBee Pro, ZigBee IP
- ZigBee Profiles: ZSE, ZHA, ZHC, ZRC
- Freescale IPv6 Mote Stack
- MQX Lite RTOS

System

- UART, SPI, I2C, optional USB 2.0 FS/LS H/D/OTG
- 16-bit ADC
- Operating range: 1.8 V to 3.6 V, -40C to +105C

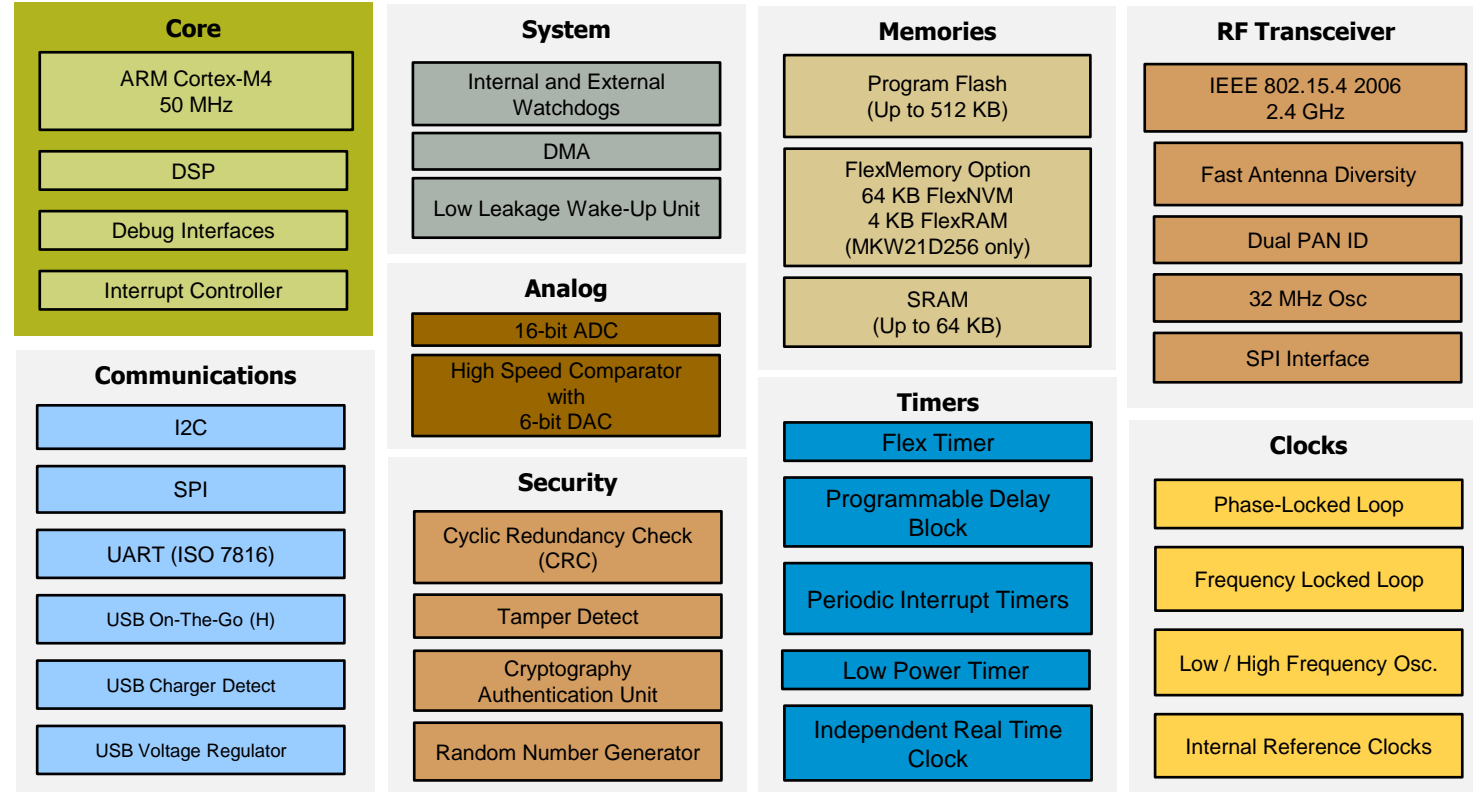

Device	Flash	RAM	Feature	Package
MKW21D256VHA5	256 KB	32 KB	No USB	8x8 63-pin LGA
MKW21D512VHA5	512 KB	64 KB	No USB	8x8 63-pin LGA
MKW22D512VHA5	512 KB	64 KB	USB	8x8 63-pin LGA
MKW24D512VHA5	512 KB	64 KB	USB and Smart Energy 2.0	8x8 63-pin LGA





Kinetis KW01 Wireless MCU (Sub 1-GHz)

- **CPU**
 - 32-bit ARM Cortex M0+ 48MHz Core
 - 128KB Flash and 16KB SRAM
- **Radio transceiver, Sub 1-GHz**
 - Supports 290-344MHz, 424-510MHz, and 862-1020MHz frequency bands
 - FSK, GFSK, MSK, GMSK and OOK modulations up to 600kbps
 - Up to -120dBm Rx sensitivity @ 1.2kbps
 - -18 to +17dBm Tx output power in steps of 1dBm
- **Ultra low power for battery operated devices**
 - Typical consumption
 - 1.7µA standby with 4.3µs wake-up time
 - <50 uA/MHz CPU system run mode
 - 16 mA Rx peak
 - 20 mA Tx peak at 0 dBm, 33 mA at +10 dBm
- **Software**
 - Simple-MAC, user modifies for their proprietary protocols
- **System**
 - 16-bit ADC, Cap Touch Sensors, I2C, UART, SPI, Timers
 - Operating Range: 1.8V to 3.6V, -40C to +85C

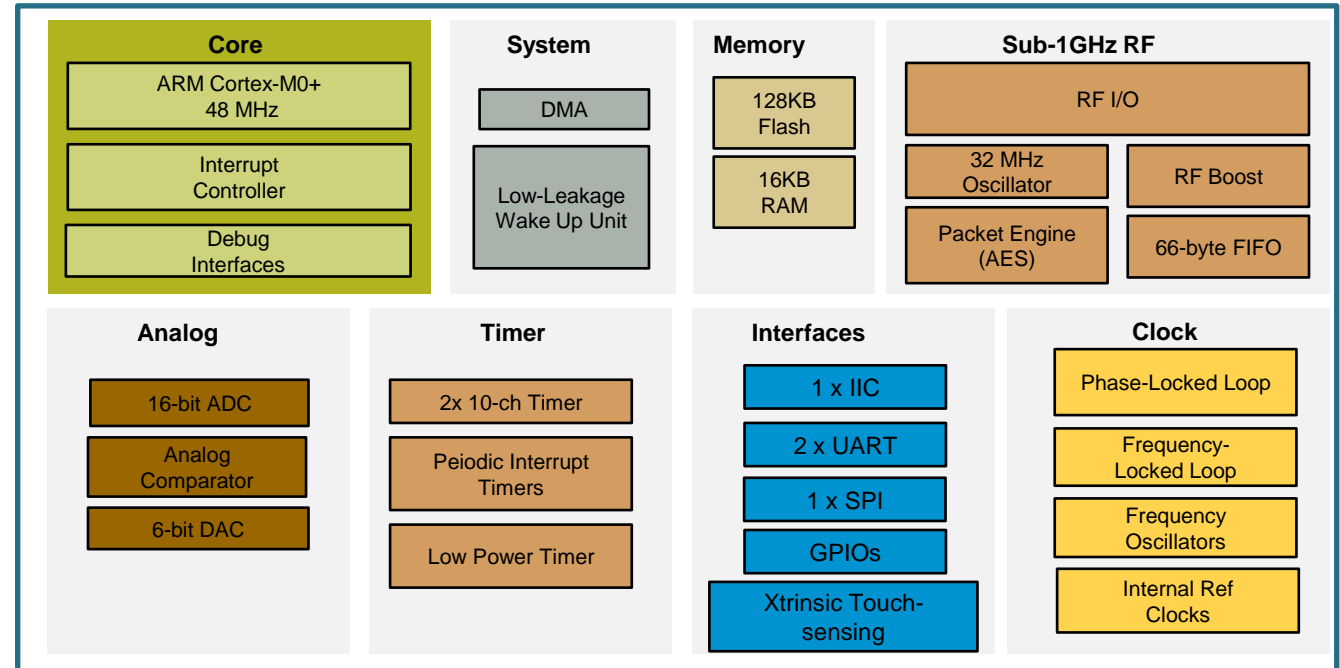

Device	Flash / Flex	RAM	Package
MKW01Z128CHN	128 KB	16 KB	8x8 56-pin LGA





Kinetis M Series MCUs

Smart Metering, Precision Measurement



Confidential and Proprietary

Freescale, the Freescale logo, ARVoc, C-E, CodeTEST, CodeWarrior, CodeFis, CodeFree, C-Ware, the Energy Efficient Solutions logo, Kinetis, iM640T, PEG, PowerQUICC, Processor Expert, QorIQ, Qorlva, SafeAssure, the SafeAssure logo, StarCore, Symphony and Vybrid are trademarks of Freescale Semiconductor, Inc., Reg. U.S. Pat. & Tm. Off. AirStar, BeeSt, BeBlack, CoreNet, Flexis, Layerscape, MagniV, MKC, Platform in a Package, QorIQ Gateway, QorIQ Engine, Ready Plug, SMARTMOS, Tower, TriadLink, UMEMI, Vybrid and Xtrinsic are trademarks of Freescale Semiconductor, Inc. All other product or service names are the property of their respective owners. © 2014 Freescale Semiconductor, Inc.



Kinetis M Series: Smart Metering & Measurement MCUs

Enabling high accuracy, secure 1-, 2- & 3-phase electricity metering solutions through a rich analog front end, hardware tamper detection and multiple low power features in a 32-bit ARM® Cortex™-M0+ MCU

Analog Front End

- High accuracy AFE with 4 x 24-bit Sigma Delta ADCs for simultaneous voltage and current measurement.
- 0.1% power measurement accuracy with high SNR of 94dB and robust ESD performance (4 kV ESD, 6 kV PESD)
- 2 x Programmable Gain Amplifiers delivering dynamic range of 200 to 1
- 12 channel, 16-bit SAR ADC inputs for accurate measurement of phase voltage in 3-phase applications
- Precision voltage reference with low drift over temperature and a phase shift compensator to simplify accurate power computation.
- Auto compensated iRTC with tamper detect, fast calibration and low drift over temperature

Security & HMI

- Core, Memory Protection Unit, Cross-Bar Peripheral Bridge, GPIO and DMA enable compliance with WELMEC & OIML regional standards requiring the separation of legally relevant (billing related) software from the main application software
- Active and passive tamper pins with automatic time stamping to protect the meter against external intrusion.
- Hardware Random Number Generator eases and speeds up support for encryption algorithms
- CRC (16/32 bits) for data integrity
- Segment LCD Controller supporting up to 288 segments and 8 backplanes. Low power blink mode operation and segment fault detect capability

Enablement

- 1, 2, & 3-phase regionally specified electricity meter Reference Designs certified to international standards
- Filter and FFT based metrology firmware provided free-of-charge
- TWR-KM34Z50M Freescale Tower System Module compatible with multiple peripheral modules from Freescale and 3rd parties
- Comprehensive peripheral library drivers
- Complimentary Freescale MQX Lite RTOS
- Freescale CodeWarrior IDE with Processor Expert code generator. ARM ecosystem support





Kinetis Enablement

Kinetis MCU Development Tools Options

Strategic Tools Partners



Freescale Products



CodeWarrior for Microcontrollers



Kinetis Design Studio

ARM Ecosystem Options





Tower System Modular Development Platforms



Modular development platform for 8-, 16- and 32-bit processors



Enables advanced development through rapid evaluation and prototyping

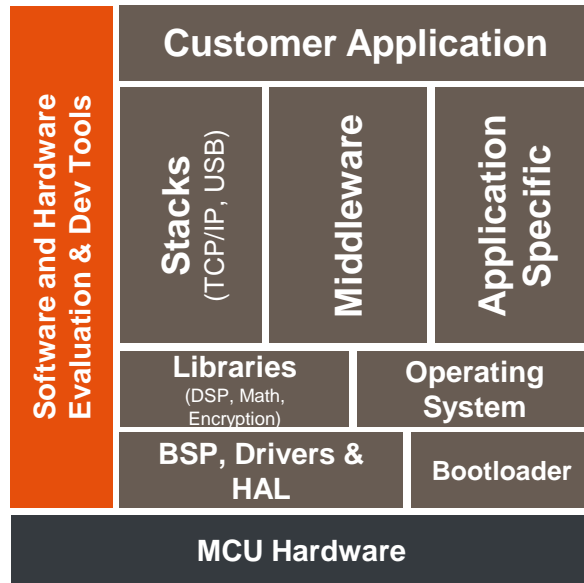

Product Features

- Modular and Expandable
 - Controller modules provide easy-to-use, reconfigurable hardware, can be used stand-alone
 - Interchangeable peripheral modules add functionality and make customization easy
 - Open-source hardware and standardized specifications promote customization
 - >80 modules to choose from
- Speeds Development Time
 - Open source hardware and software allow quick development with proven designs
 - Integrated debugging interface allows for easy programming and run control via standard USB cable
- Cost Effective
 - Sold individually and in complete kits, typically starting at \$69 USD.
 - Tool re-use through interchangeable modules eliminates need to purchase redundant hardware





Freescale Freedom Development Platforms



Ultra low-cost/low-power development platform



Enables quick application prototyping and demonstration of **Kinetis MCU families**

Product Features

- Low-cost (\$12-29USD MSRP)
- Designed in an industry-standard compact form factor (Arduino R3)
- Easy access to the MCU I/O pins
- Integrated open-standard serial and debug interface (OpenSDA)
- Compatible with a rich-set of third-party expansion boards

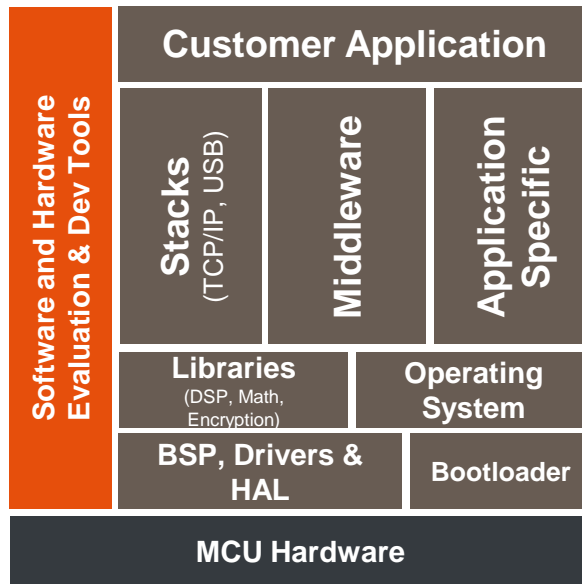

FRDM-KL25Z



FRDM-KL05Z



FRDM-KL46Z

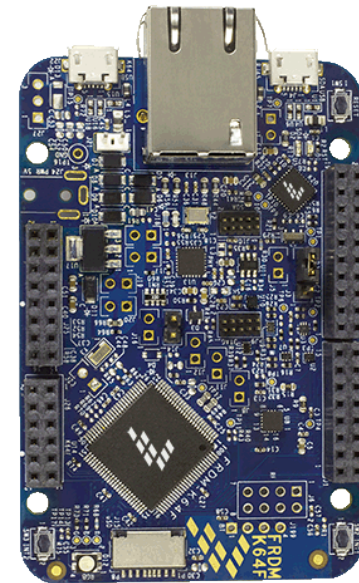

FRDM-K64F
(coming April 2014)



Freescale MQX™ Software Solutions



Commercial-grade MCU software platform at no cost with optional support packages



Enabling the development of connected and intelligent applications of the future

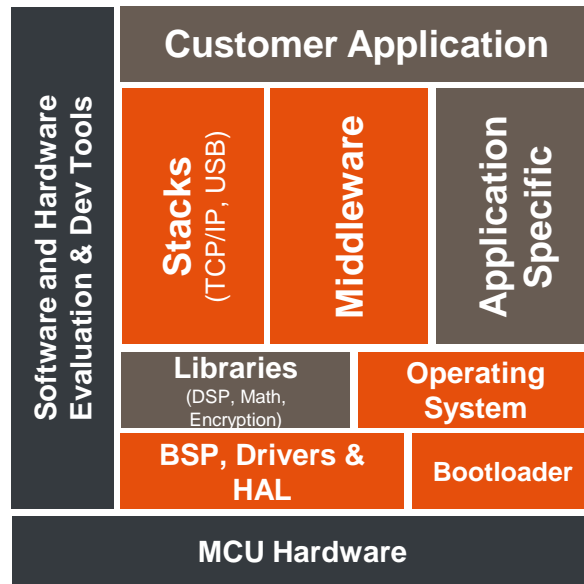

Product Features

- MQX™ Real Time Operating System Kernel
 - Deterministic multi-tasking preemptive scheduler
 - Extensive inter-task synchronization, message passing, and much more
- MQX™ Real Time Communication Suite

Now with optional IPv6 add-on package

 - Broad networking protocol support (TCP,UDP, ICMP, HTTP, DHCP, FTP, Telnet, ...)
 - Fully re-entrant, responsive, designed for embedded systems
- MQX™ File System
 - Embedded FAT file system compatible with FAT-12, FAT-16, or FAT-32 file systems
- MQX™ USB Host/Device Stack
 - USB 1.0/2.0; low-/full-/high-speed
- Board Support Packages
 - Pre-configured MQX Kernel, stacks, and peripheral drivers for Freescale HW





Freescale MQX™ Lite



Very light MQX™ kernel for Kinetis MCUs



Easy to configure – packaged as a Processor Expert component

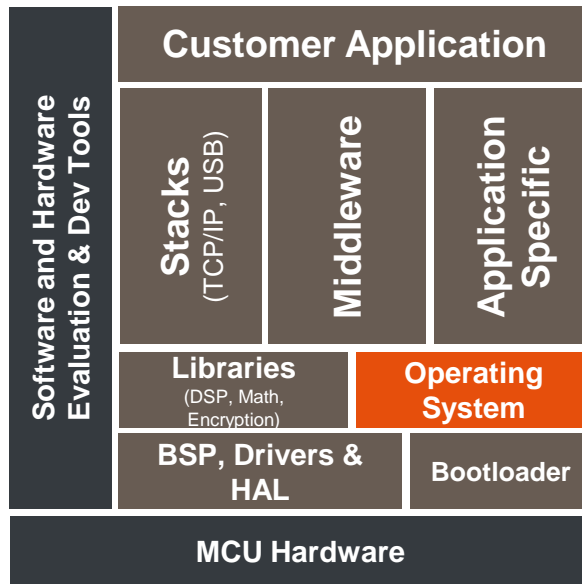

Product Features

- MQX™ Real Time Operating System Kernel
 - Lite configuration of MQX™ Kernel requiring less than 4 KB RAM
 - All lightweight components
 - Static memory allocation
- Packaged as a Processor Expert component
- Get started in minutes – Just drop in the MQX™ Lite RTOS component to your project
- I/O capability provided by Processor Expert
- Upward code migration – MQX™ Lite RTOS is a true subset of the full MQX™ RTOS
- Available for all Kinetis K-, L-series devices and select E-series devices
- Get now within the [Processor Expert Driver Suite](#) and [CodeWarrior Development Studio for MCUs](#)





MQX & MQX Lite Comparison

	MQX RTOS	MQX Lite RTOS
Delivery Mechanism	Traditional installer with full source for Kernel, services and Board Support Packages	Processor Expert (PEX) Kernel and services component
I/O Drivers	MQX POSIX compatible drivers with option for using PEX drivers	PEX drivers only
Configurability	User selects needed services from full or lightweight versions	Reduced services available; lightweight options only
Example Footprint (3 tasks, sem, event)	<10 Kbytes FLASH	<8 Kbytes FLASH
Components	Kernel, TCP/IP stack, USB stack, file system, middleware, and peripheral drivers.	Kernel only, with additional components including USB stack provided by PEX
Availability	Kinetis K Series, Vybrid, select ColdFire, select Power Architecture	Kinetis L Series, Kinetis K Series, select Kinetis E Series





www.Freescale.com