

DC Power 제어분석 소프트웨어 를 활용한 다양한 전력 측정 및 분석

**키사이트 테크놀로지스
최대류 부장**

Agenda

- Quick Review – N6705B / N7900A
- DC Power Analysis Software – 14585A
- Applications and Demos
 - **Arbitrary Waveform Generation(ISO standard waveforms)**
 - **DC motor Supplies and Analysis(Power Drill)**
 - **Super Capacitor Measure**
 - **Wireless Product Analysis**
 - **Medical / Environmental / Fan / walkie-talkie**
- Conclusion

N6705B DC Power Analyzer

Award Winning Solution

The N6705 boosts the productivity of the R&D Engineer

Multiple instrument functionality in a single box

- 1 to 4 advanced power supplies
 - Digital voltmeter and ammeter
 - Arbitrary waveform generator
 - Oscilloscope
 - Datalogger
- All functions and measurements available from the front panel
 - Utilizes the same modules in the N6700 family
 - 600W total output power



Gain insights into a DUT's power consumption – in minutes, not hours – without writing a single line of code!



N6705B DC Power Analyzer

Key Specifications

Number of outputs: Takes 1 to 4 DC Power Modules

Total output power: 600 W (= sum of 4 outputs)

Max current per output: 20 A (through binding posts) or 50 A (circumvent binding posts)

Max voltage per output: 100 V; can put in series for higher V

Available power per output: 20 W, 50 W, 100 W, 300 W

Ammeter accuracy: Up to 0.025 % + 8 nA (SMU)

Up to 0.5 % + 100 nA (Precision module with 2UA option)

Up to 0.10 % + 4 mA (Hi-Performance module)

Scope: Up to 200 kHz digitizer, 512kpts, 18 bits

Arb bandwidth: Up to 100 kHz_(SMU), 4.5 kHz_(Precision), 260 Hz_(Basic)

Data Logger sample interval: 20 μ s minimum, 1 minute maximum

Data Logger maximum log size: 500 Million readings

Internal non-volatile memory: 1 GB (=256 million readings)

Module Dependent

Zero Shunt

Traditional Measurement Solutions for Battery Drain Test

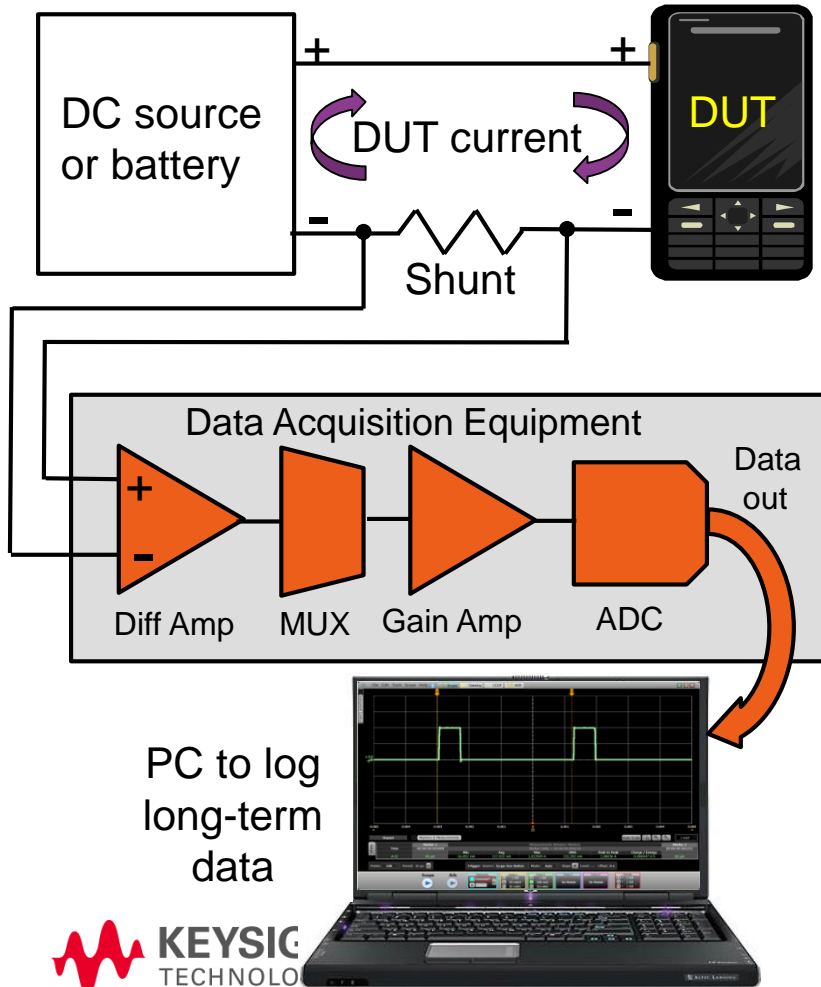

Most common: Shunt + DAQ equipment

- Typical Performance:
 - ~14 to 16 bits
 - ~200K to 1M samples/sec
 - ~0.2 to 1.0% gain error (both shunt and DAQ)
 - ~ **0.02 to 0.1% offset error (mainly DAQ)**
- Commonly Encountered Issues:
 - Peak voltage drop on shunt may be excessive
 - Transient voltage drop at DUT when using a GP DC source can be excessive
 - Large effort to configure and program
 - **Fixed offset error is 200 to 1,000 times greater than target of 0.0001%**

The fixed offset error of most traditional test equipment limits their performance measuring battery current drain signals

Zero Shunt

Realistic assessment of a DUT's performance is with its battery

- Logging battery run-down voltage and current yields insights about the device and its battery in combination as a system
- N6781A features a Measure-only operating mode for battery run-down testing:
 - N6781A's output regulates zero volts while measuring current, becoming a zero-burden ammeter. Eliminates voltage drop problems that current shunt resistors have
 - N6781A's Auxiliary DVM input simultaneously logs battery voltage

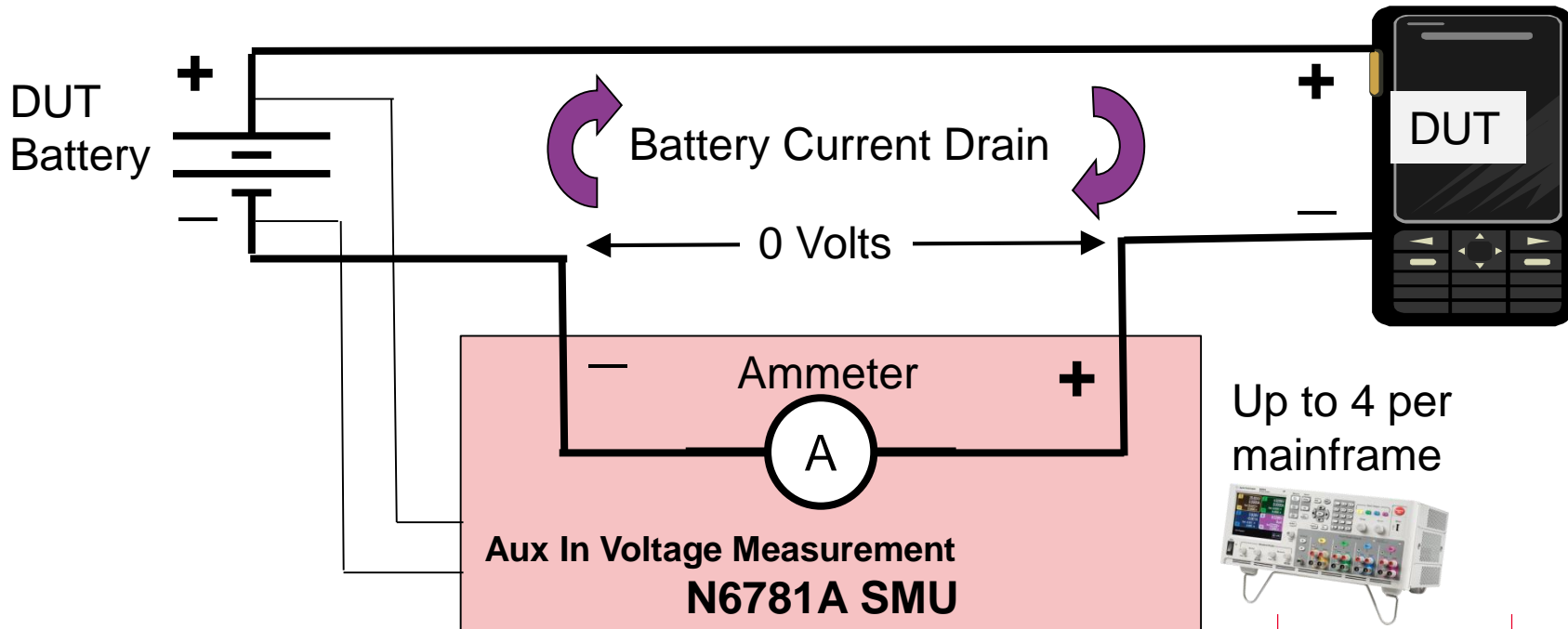

Seamless Current Measurement

All new, Agilent-exclusive feature – never been done before

- Can change range, without glitch, mid-sweep and not lose any readings
- 200 kHz, 18-bit digitizer acts like single range of ~28-bits
- Allows for accurate measurements from Amps to μA during a single scope sweep or data log (1,000,000:1)

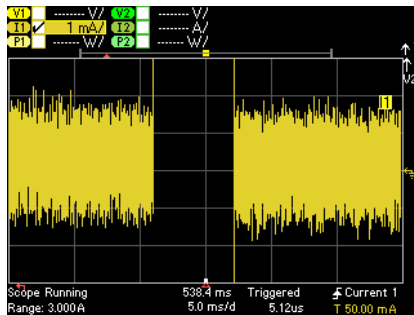

Seamless Off

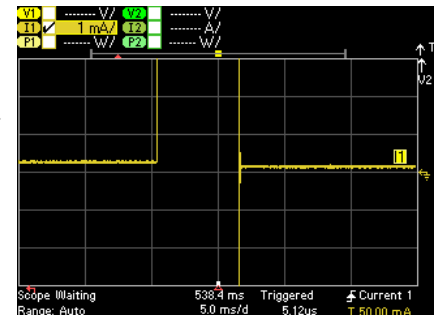
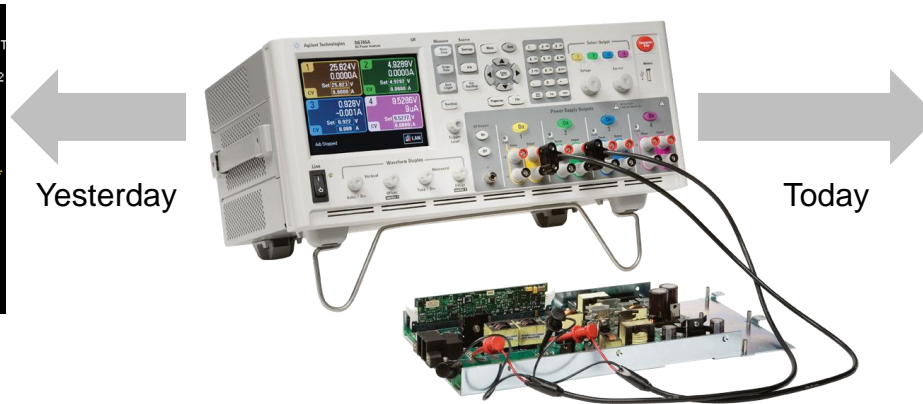

Seamless On

**– See the complete current waveform you’ve never seen before
– from nA to A –
in one pass and one picture**

Seamless Current Measurement

Think: Vertical Mega-Zoom

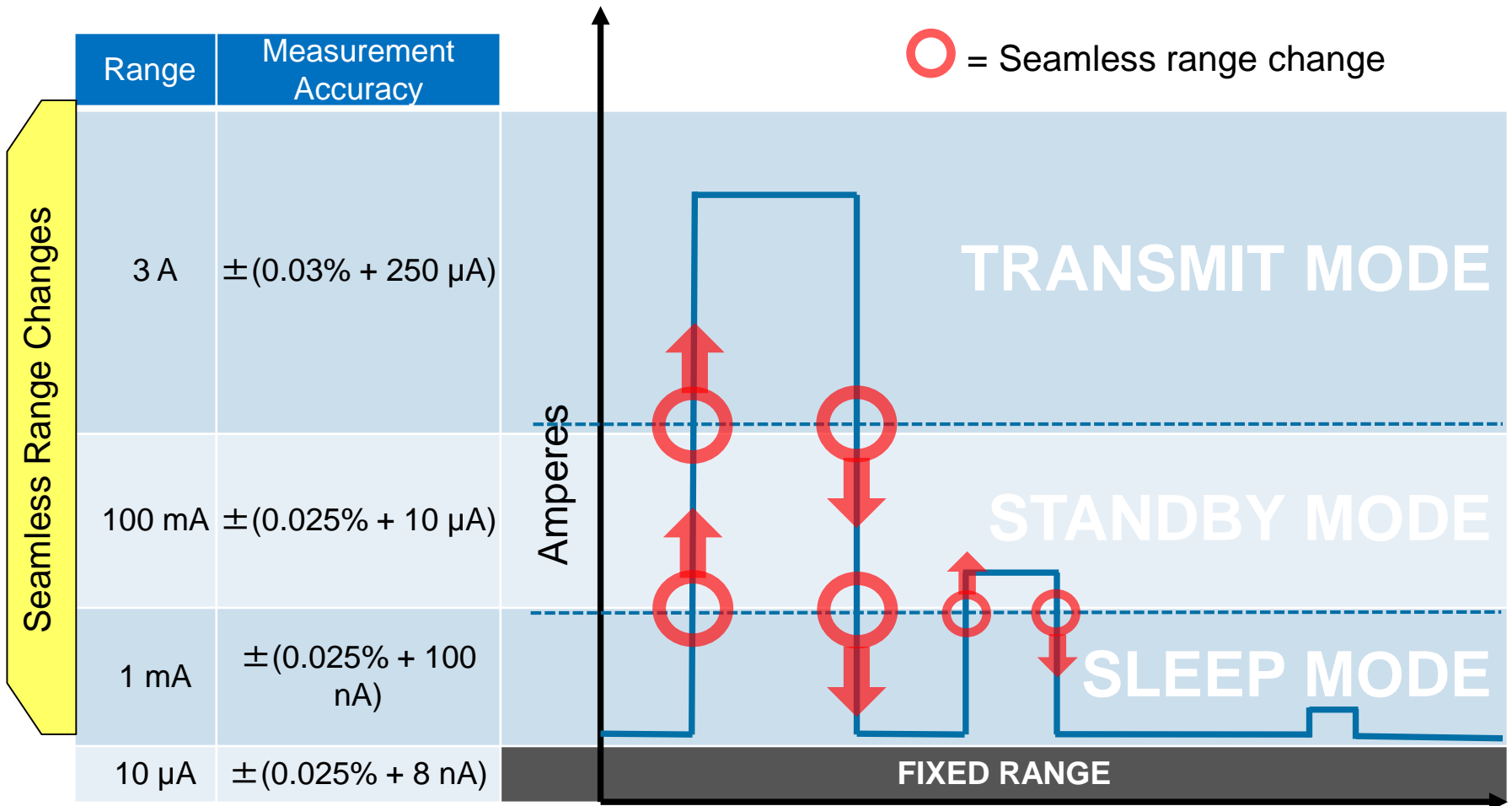

**See the complete current waveform you've never seen before
– from nA to A –
in one pass and one picture**

Advanced Power System – N6900/N7900

	1000 W	2000 W
N6900 Series Supplies	5 models 9V/100A to 80V/12.5A	7 models 9V/200A to 160V/12.5A
N7900 Series Dynamic Supplies <i>More performance, more capability</i>	5 models 9V/100A to 80V/12.5A	7 models 9V/200A to 160V/12.5A



Plus: Black Box Recorder
1000 W Power Dissipater Unit

- *Highly differentiated, high performance, high capability power supplies*
- *Antithesis of the notion that a power supply is just a “battery with a knob”*

Advanced Power System – N6900/N7900

Basic Power Supply Just A Power Supply (JPS)	System Power Supply (SPS)	Advanced Power System (APS)
---	--	--

- ***APS is not “just a power supply” (e.g., N57xx or N87xx or N89xx)***
- ***APS is more than other System Power Supplies***

Before APS	With APS
<ul style="list-style-type: none">• <i>SPS</i>• <i>eLoads</i>• <i>Measurement (shunts, digitizers, DMMs)</i>• <i>Switching</i>• <i>Home-brew “glue” + other devices</i>	<ul style="list-style-type: none">• <i>APS (It’s all in there!)</i> 

Advanced Power System – N6900/N7900

Nine Test Challenges

- Key part of product message
- Things that APS can do that others cannot



Test Challenges have been well received

- But how to make the connection between the Test Challenges and actual applications?

Increasing test system throughput

Challenge: Reducing test time to increase test throughput is a continuous goal in high volume manufacturing

How the APS overcomes this:

- Fast output speed
- Output List mode
- Smart triggering
- Fast command processing

www.agilent.com/find/throughput

Building a continuous source and load

Challenge: Building a continuous source and load solution >500W for testing power storage related DUTs.

How the APS overcomes this:

- 2-quadrant operation
- V and I level triggering
- Fast output speed and response

www.agilent.com/find/SourceLoad

Protecting against power related damage

Challenge: Protecting costly DUTs from power related damage during test.

How the APS overcomes this:

- Smart triggering
- Fast output response
- Output disconnect relays
- Watchdog timer

www.agilent.com/find/ProtectDUT

Characterizing dynamic current profiles

Challenge: Capturing the current profile of a DUT that has a large dynamic current range.

How the APS overcomes this:

- Current digitizer
- Seamless ranging
- Adjustable sample rate
- External logging

www.agilent.com/find/DynamicCurrent

Generating power transients

Challenge: Simulating power transients during test to ensure the DUT can standup to real world power conditions

How the APS overcomes this:

- AWG capability
- Step function capability
- High bandwidth mode

www.agilent.com/find/PowerTransients

Characterizing inrush current

Challenge: Capturing the large current surge that occurs powering on DUTs with reactive elements at the input.

How the APS overcomes this:

- V and I digitizers
- Pre- and post-triggering
- Large measurement range

www.agilent.com/find/InrushCurrent

Maintaining output integrity under dynamic load conditions

Challenge: Maintaining a stable output voltage free of oscillations and voltage droop while under a very dynamic load

How the APS overcomes this:

- Fast transient response
- High and low output bandwidth modes
- Long test lead tolerance

www.agilent.com/find/PowerIntegrity

Tracking power events for root-cause analysis

Challenge: Tracking power events during test for root cause analysis if your expensive DUT is damaged during test.

How the APS overcomes this:

- Built-in Black Box Recorder
- Records voltage, current, power, trigger events and more

www.agilent.com/find/PowerTracking

Properly powering on/off a DUT

Challenge: Properly sequencing on multiple supplies and tuning slew rates to prevent damage.

How the APS overcomes this:

- Sequencing across mainframes
- Sequencing with N6700 mainframes
- Adjustable slew rate control

www.agilent.com/find/PoweringDUT

DC Power Analysis Software – 14585A

Easily access advanced features

- N7900 Advanced Power System
- N6705 DC Power Analyzer



① Control

Access all features of the power supply via virtual front panel

② Measurements

Scope and Data Logger Modes

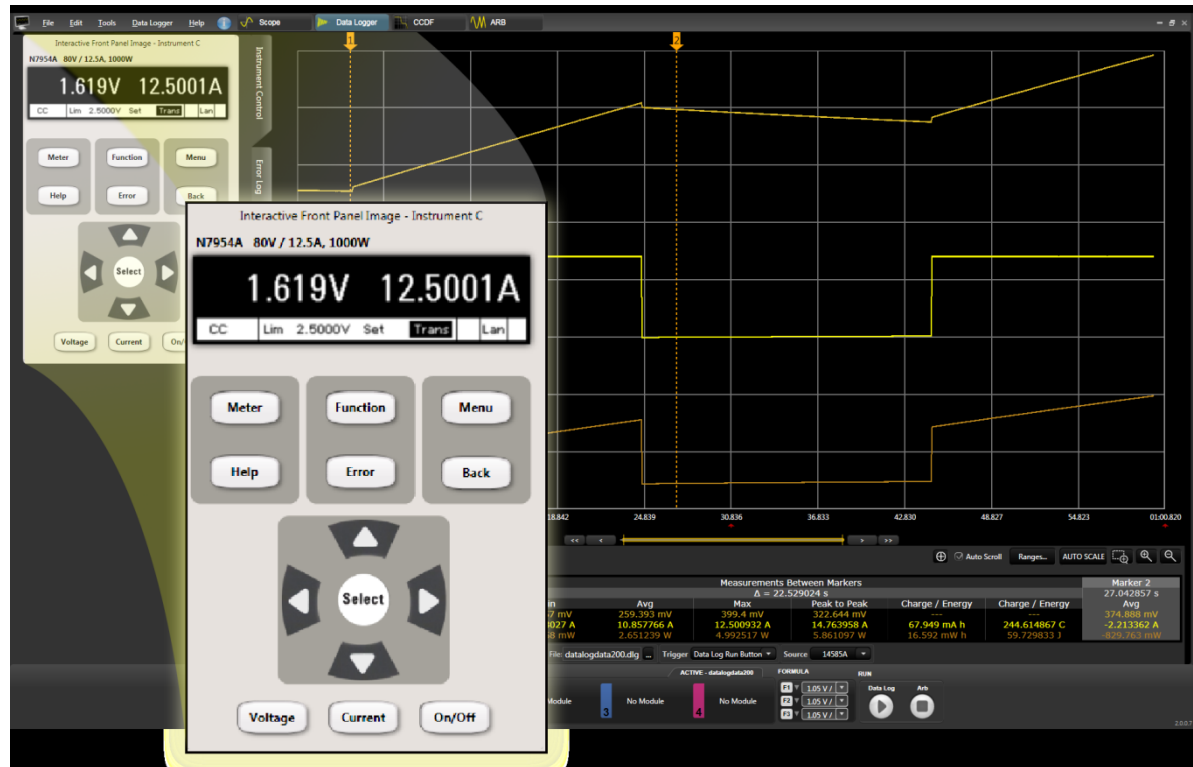

DC Power Analysis Software – 14585A

③ Arbitrary Waveforms (yes, on DC!)

Predefined Waveforms

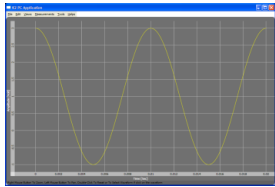

Ramp, Sine, Triangle, Saw Tooth, Exponential, Stair Step, Square, Gaussian, Random noise

From Formula



15 primitive function: abs(),acos(),log(), etc
 12 high level functions: AM,PWM, gauss(), etc
 6 operators: +,-,*,/,^,%

From Memory

Data copied from Clipboard



Arb Generator Window



Add/Insert/Delete waveforms
 Run/Stop waveform
 Edit data by sheet
 Pan and Zoom in /out
 Change time scale/offset
 Change vertical scale/offset
 Auto scale
 Show/change parameter of waveform
 Show/change trigger settings

④ Record and Playback

Combine Measurement, Arb, & Source/Sink Capabilities

Run



Run the Arbitrary waveform

Export / Save



Tabbed/CSV/XML text files
 Binary format files
 Clipboard: Bitmap Image
 Clipboard: paste data

Print

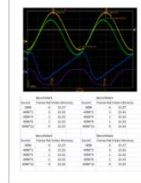

One page summary

AWG Generation

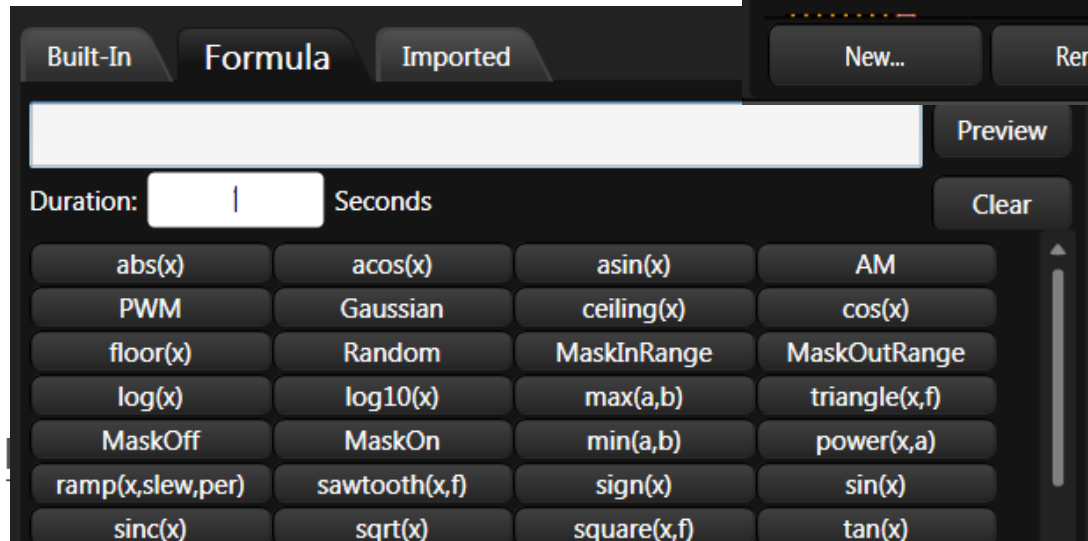
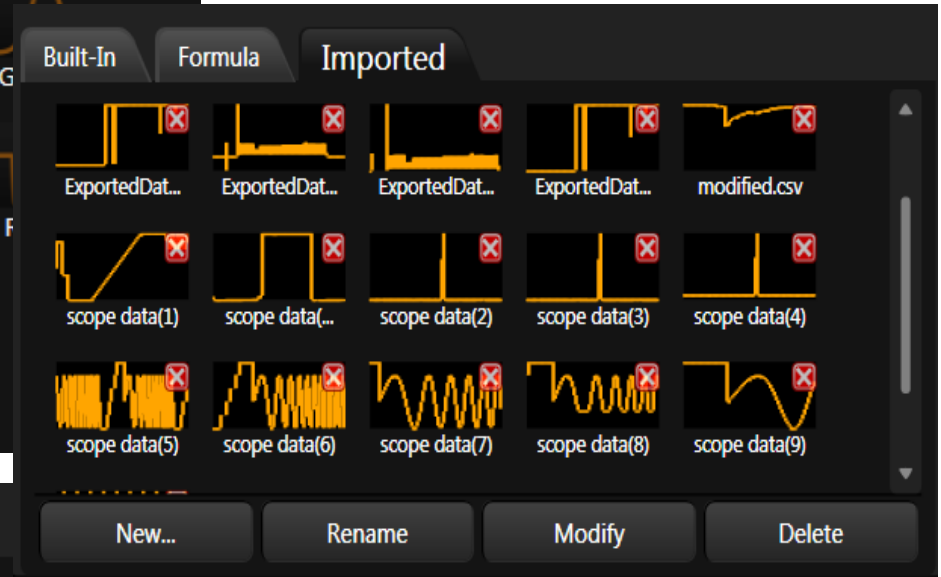
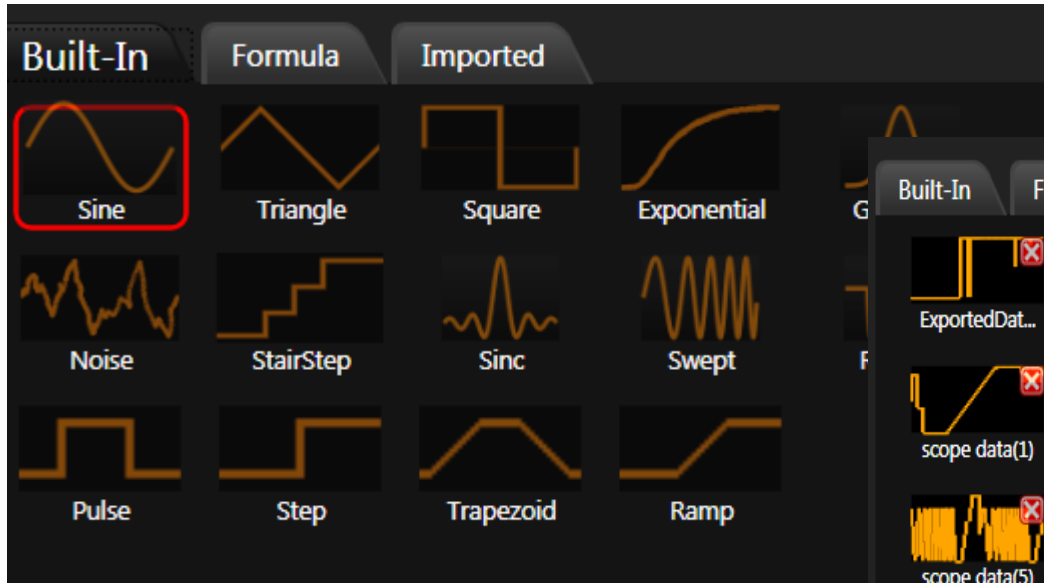

ISO 16750-2 Waveforms - Automotive

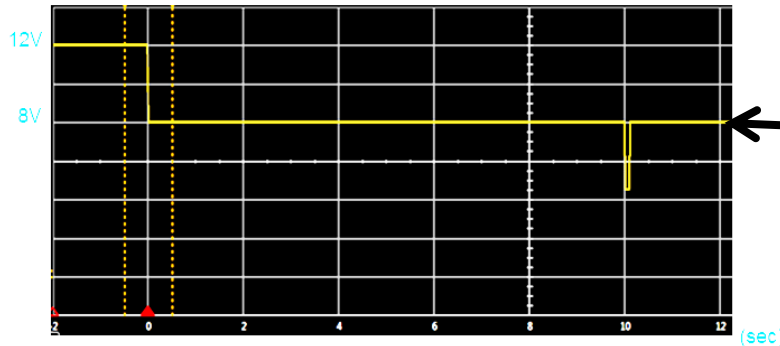

Momentary Drop in Supply Voltage. Simulates a 0.1s drop due to electrical load suddenly short-circuiting followed by its fuse opening.

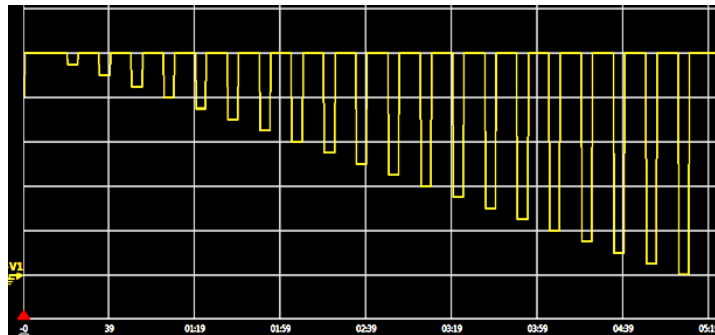

Reset behavior at voltage drop: series of 5s-duration voltage drops spaced 10s apart, increasing by an additional 5% drop in amplitude each time.

Starting profile: series of voltage ramps slewing from 1-10's of msec at beginning & end with a second long period of a sine wave superimposed on DC embedded in the middle to emulate steady-state crank portion

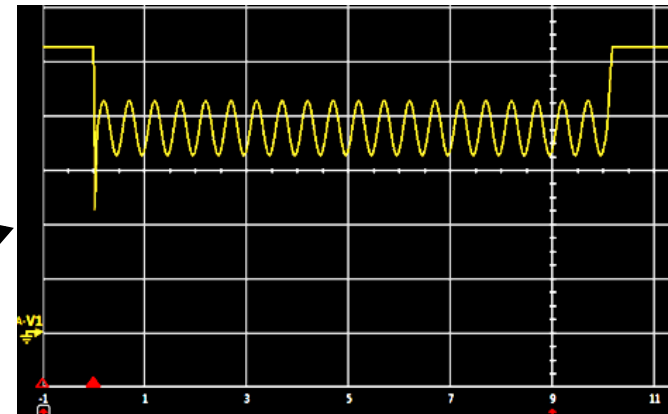

Power Drill Demo



Scope Analysis : Triggering / Protection / OCP Delay

Super Capacitor Demo



N7900 APS + N7909A Dissipater



16.5 Farad 16V Hybrid Capacitor

Logger: Theory / Charging / Discharging / Current AWG / Function

Capacitor / ESR

$$I = C * dv/dt$$

$$C = I * dt/dv$$

$$dt = C * dv / I$$

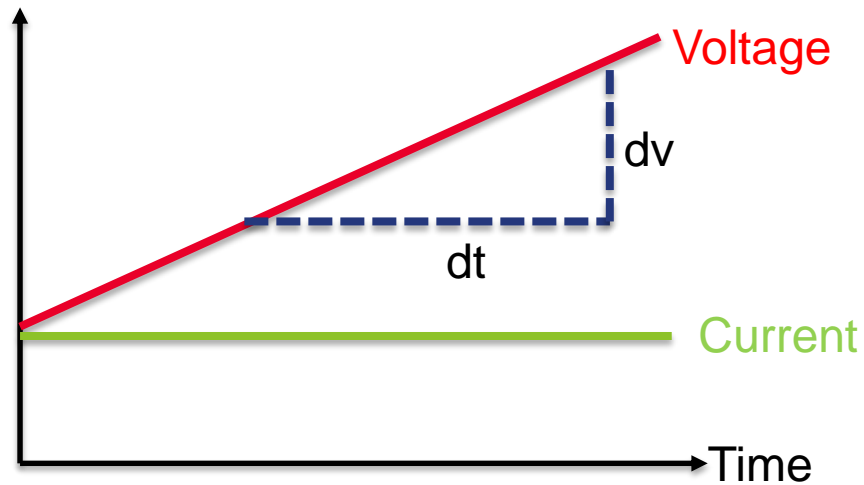

Capacitor / ESR

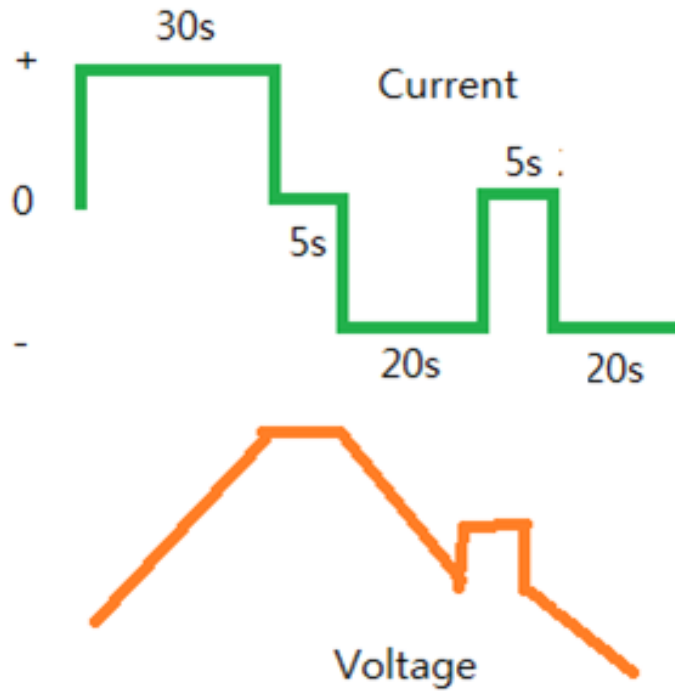

C	16.5F
I	10A
Vlim	16.2V
dt (max)	26.73s

Capacitor / ESR

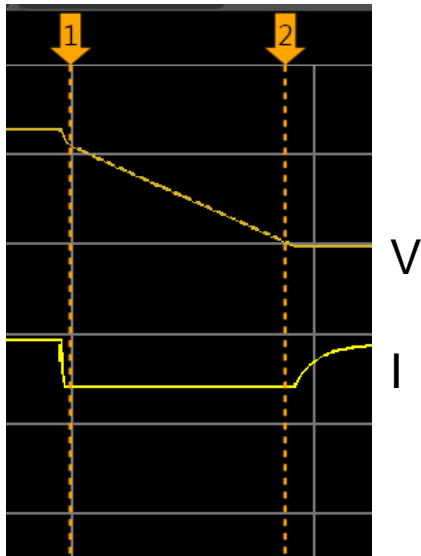

$$C = I * dt/dv$$

$$(I1MTWO * MDELTA) / (V1MTWO - V1MONE)$$

$$ESR_{DC} = (V_f - V_{min}) / I_d$$

$$(V1MTWO - V1MONE) / I1MTWO$$

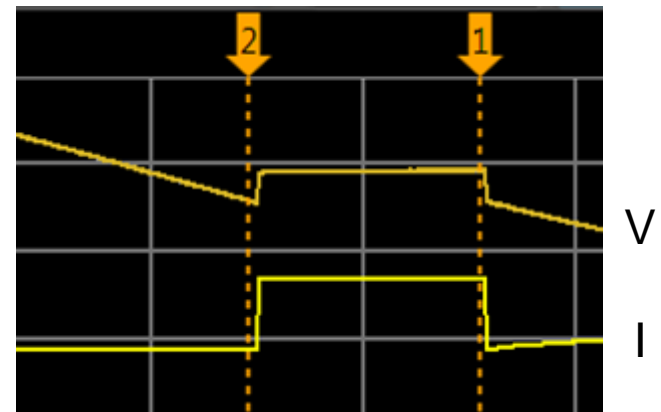

Wireless Product Analysis

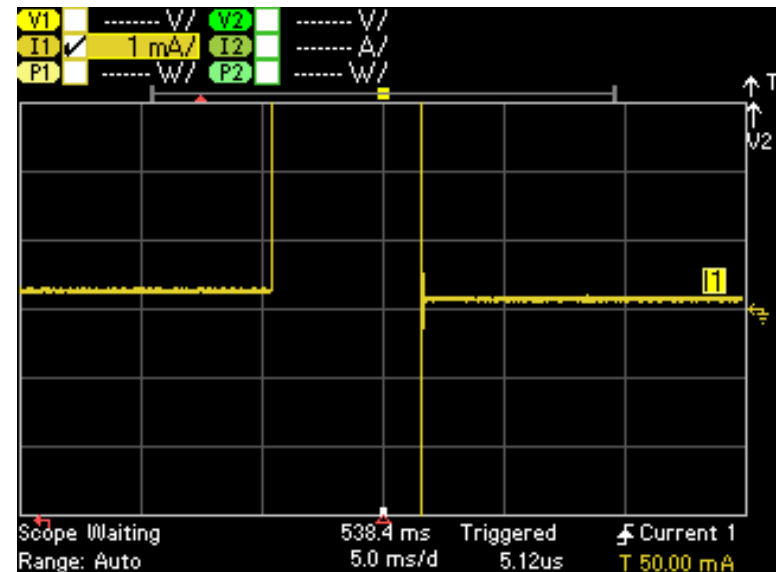
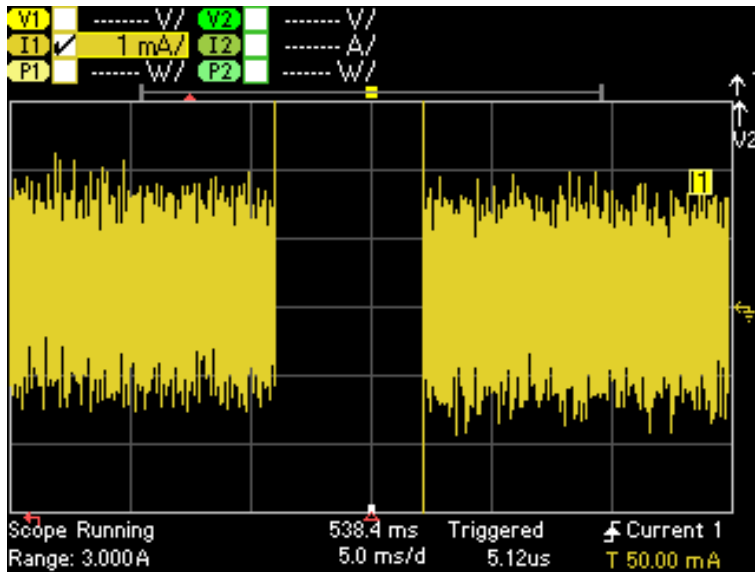

**Range / Seamless Measure /
Sleep current / AWG Load**

Medical / Environmental / Fan / walkie-talkie



Conclusion

DC Power 제어분석 소프트웨어를 이용하시면 임의 파형 생성, 임의 함수 측정, 미세 전류 측정, 소모전류 분석, 장기간의 신호 추이 저장(로깅), 반복 측정, 장비보호 설정 등 다양한 기능을 별도의 프로그램 제작없이 수행할 수 있으며, 쉽고 빠르게 원하는 측정 결과를 도출하고 재현할 수 있습니다.

