

Wireless Product Introduction

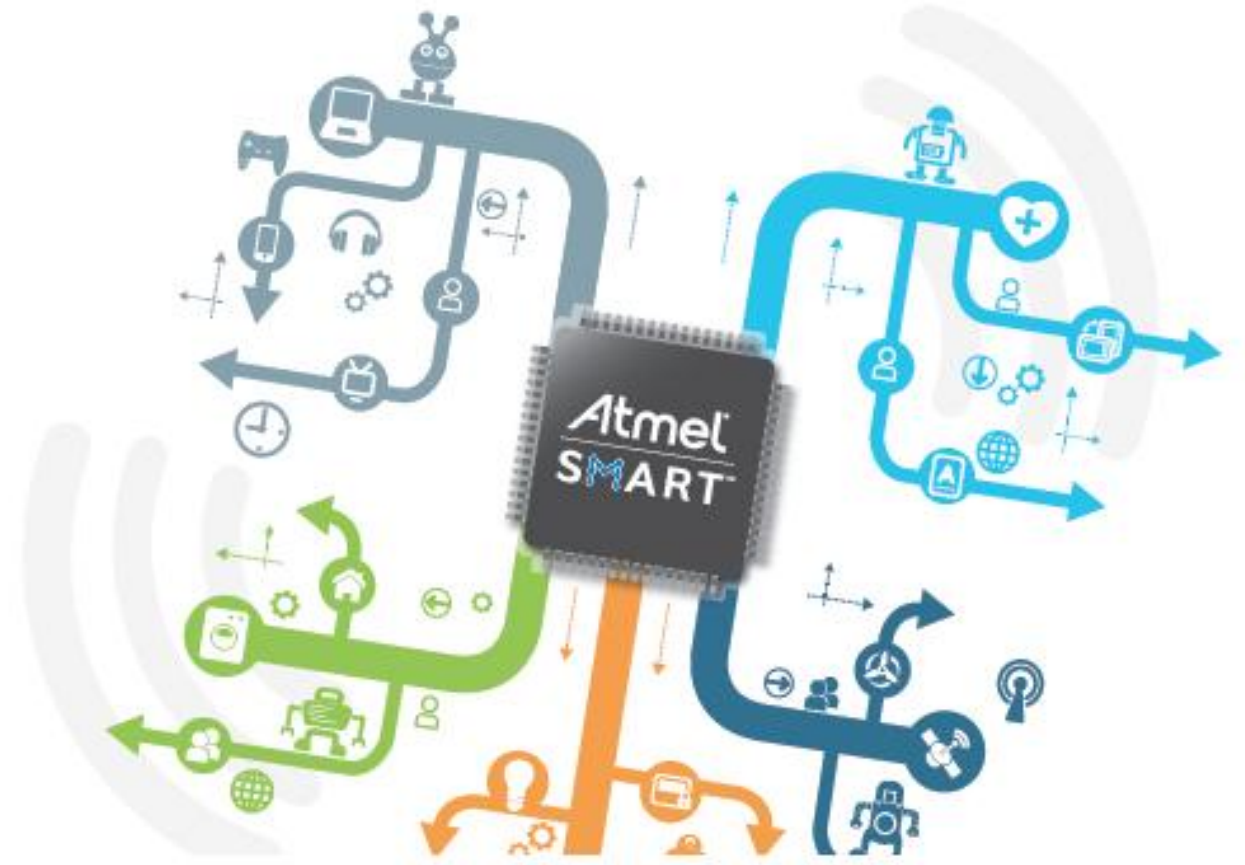

Willy Son

Atmel Wireless Product Marketing

The Opportunity: Expected Market Acceleration for IOT

>30B Connected devices by 2020

- ABI Research, 6/2015

~100 Expected # of connected devices per household

- Atmel Estimate

4.5B # of smart phone Subscriptions by 2018

- Ericsson Mobility Report, 6/2015

42% of World Wide Households will have Wi-Fi by 2016

- Strategy Analytics

50% of IoT Solutions will be provided by startups which are less than 3 years old by 2019 - Gartner

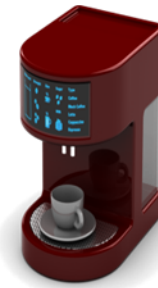

The Opportunity: Expected Market Acceleration for IOT

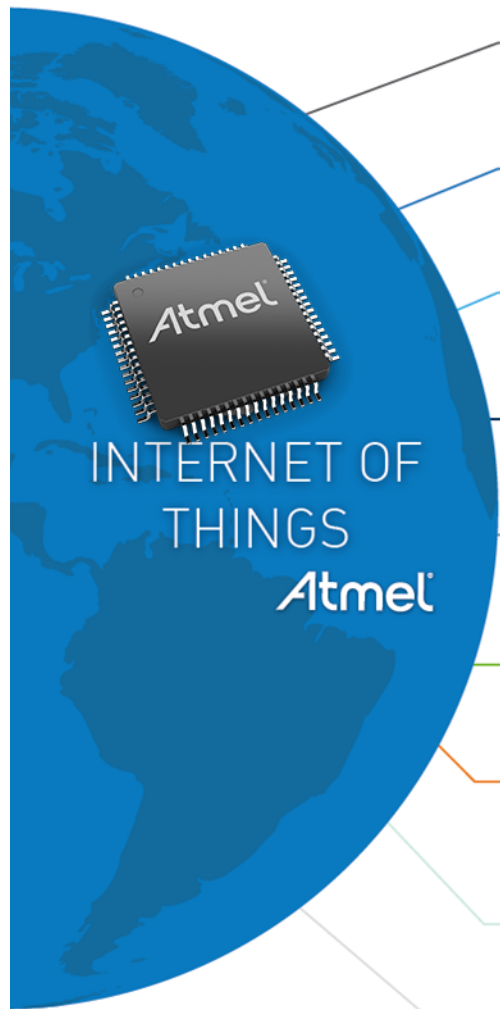

SERVICE SECTOR	APPLICATION GROUPS	LOCATIONS	DEVICES
BUILDINGS	Commercial/Institutional	Office, Education, Retail, Hospitality, Healthcare, Airports, Stadiums	HVAC, Transport, Fire & Safety, Lighting, Security, Access, etc.
	Industrial	Process, Clean Room, Campus	
ENERGY	Supply/Demand	Power Gen, Trans & Dist, Low Voltage, Power Quality, Energy Mgmt	Turbines, Windmills, UPS, Batteries, Generators, Meters, Drills, Fuel Cells, etc.
	Alternative	Solar, Wind, Co-generation, Electrochemical	
	Oil/Gas	Rigs, Derricks, Well Heads, Pumps, Pipelines	
CONSUMER & HOME	Infrastructure	Wiring, Network Access, Energy Mgmt	Digital Cameras, Power Systems, MID, Dishwashers, e Readers, Desktop Computers, Washer, Dryers, Meters, Lights, TVs, MP3, Games Consoles, Lightening, Alarms, etc.
	Awareness & Safety	Security/Alerts, Fire Safety, Environ. Safety, Elderly, Children, Power Protection	
	Convenience & Entertainment	HVAC, Climate, Lightening, Appliance, Entertainment	
HEALTHCARE & LIFE SCIENCE	Care	Hospital, ER, Mobile POW, Clinic, Labs, Doctor Office	MRI, PDAs, Implants, Surgical Equipment, Pumps, Monitors, Telemedicine, etc.
	In Vivo/Home	Implants, Home Monitoring Systems	
	Research	Drug Discovery, Diagnostics, Labs	
INDUSTRIAL	Resource Automation	Mining, Irrigation, Agricultural, Woodland	Pumps, Valves, Vats, Conveyors, Pipelines, Motors, Drives, Converting, Fabrication, Assembly, Packaging, Vessels/Tanks, etc.
	Fluid/Processors	Petro-Chem, Hydro Carbons, Food/Beverage	
	Converting Discrete	Metals, Paper, Rubber, Plastic, Metalworking, Electronics, Assembly Test	
	Distribution	Pipelines, Mat'l Handling Conveyance	
TRANSPORTATION	Non-Vehicular	Air, Rail, Marine	Vehicles, Lights, Ships, Planes, Sign age, Tolls, etc.
	Vehicles	Consumer, Commercial, Construction, Off-Highway	
	Trans/Systems	Tolls, Traffic Mgmt Navigation	
RETAIL	Specialty	Fuel Stations, Gaming, Bowling, Cinemas, Discos, Special Events	POS Terminals, Tags, Cash Registers, Vending Machines, Signs, etc.
	Hospitality	Hotels, Restaurants, Bars, Cafes, Clubs	
	Stores	Supermarkets, Shopping Centers, Single Site, Distribution Centers	
SECURITY/ PUBLIC SAFETY	Surveillance	Radar/Satellite, Envim, Military Security, Unmanned, Fixed	Tanks, Fighter Jets, Battlefield Comms, Jeeps, Cars, Ambulances, Breakdown, Lone Worker, Homeland Security, Fire, Environ. Monitor, etc.
	Equipment	Weapons, Vehicles, Ships, Aircraft, Gear	
	Tracking	Human, Animal, Postal, Food/Health, Packaging, Baggage	
	Public Infrastructure	Water Treatment, Building Environ. Gen. Environ., Surveillance	
	Emergency Services	Equip. & Personnel, Police, Fire, Regulatory	
IT & NETWORKS	Public	Services, E-Commerce, Data Centers, Mobile Carriers, Fixed Carriers, ISPs	Servers, Storage, PCs, Routers, Switchers, PBXs, etc.
	Enterprise	IT/Data Center, Office, Private Nets	

Scalable Family of Atmel | SMART and AVR

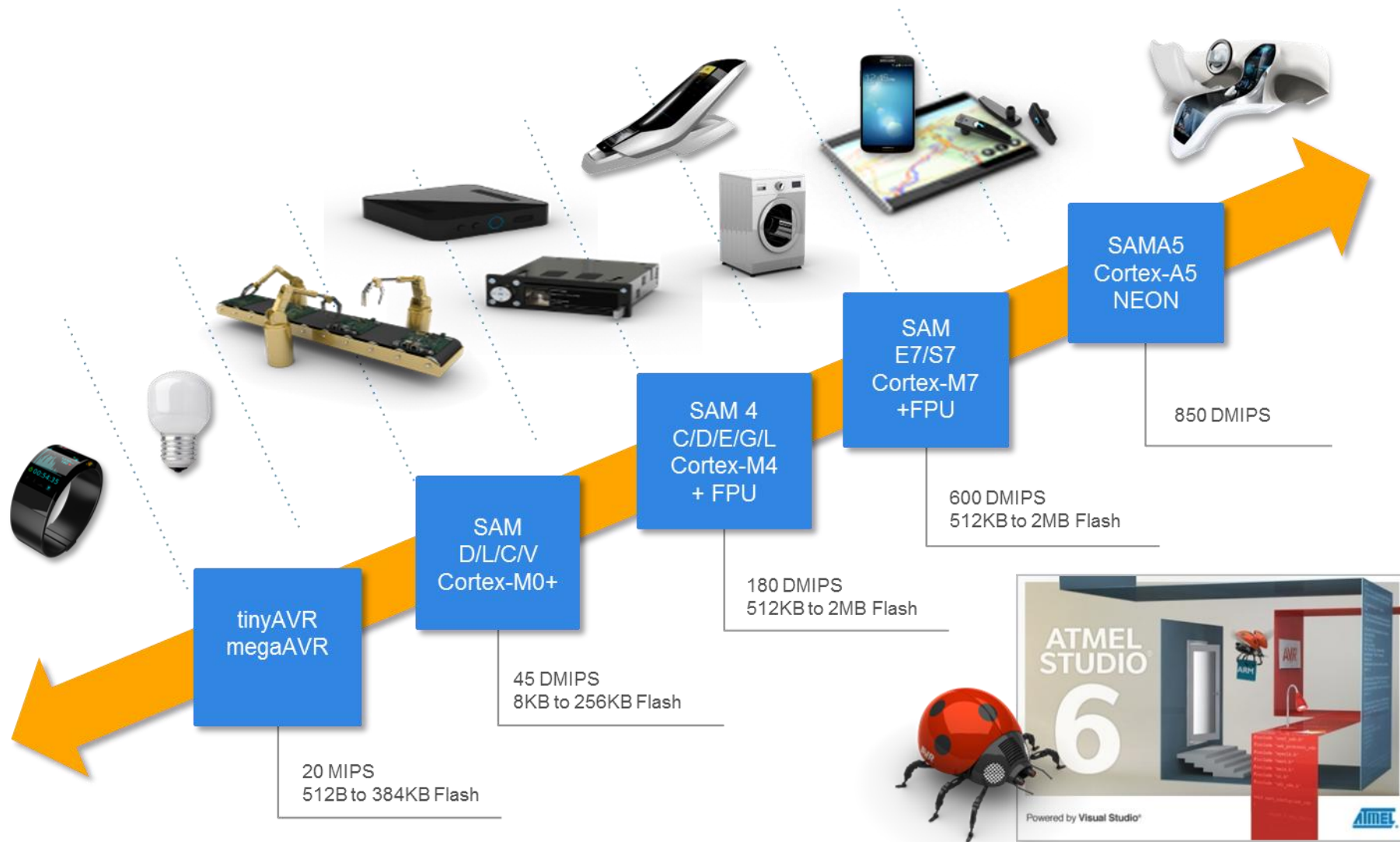

Scalable Family of Atmel | SmartConnect



IOT Infrastructure of End device to cloud connectivity



Embedded Developers

Backend Services Developers

- Transportation
- Healthcare
- Industrial
- Energy
- Home
- Lifestyle

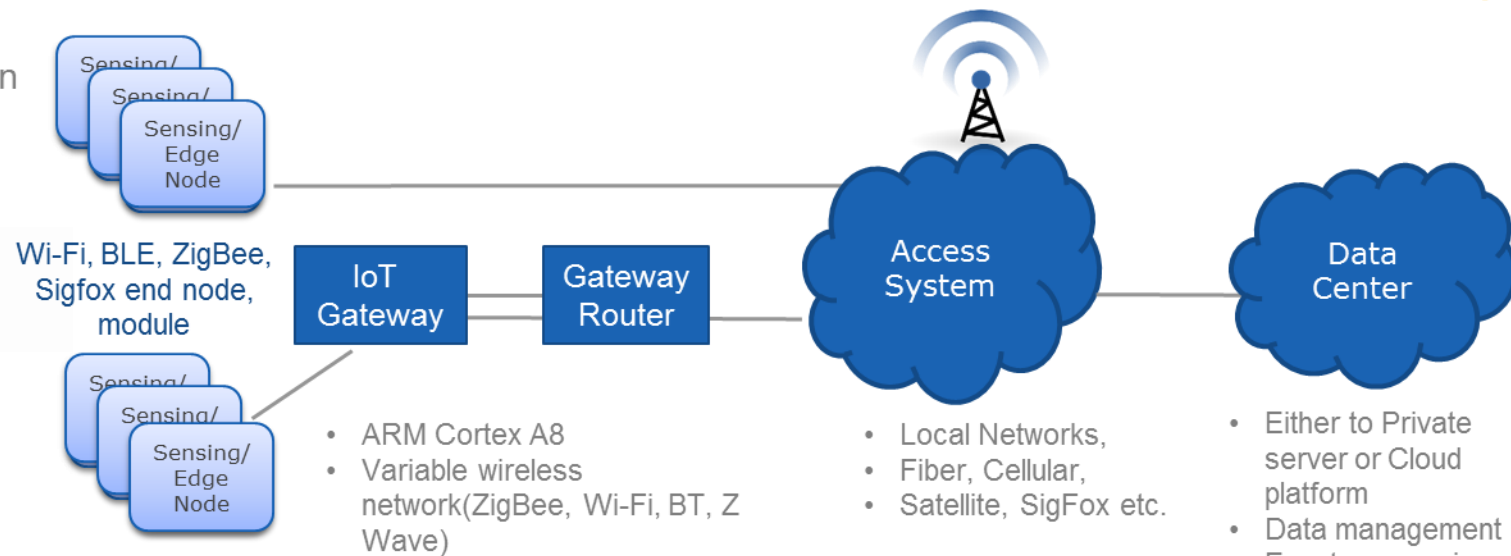

Wi-Fi, BLE, ZigBee, Sigfox end node, module

- ARM Cortex A8
- Variable wireless network(ZigBee, Wi-Fi, BT, Z Wave)

- Low end MCU(cortex M0~M4)/Non OS,RTOS
- Real time processing
- Sensor & Actuator control
- Battery power low power consumption
- Security(TLS, AES128, SHA256, ECC508)
- Network Protocol(MQTT, CoAP, Resfull)

- Local Networks,
- Fiber, Cellular,
- Satellite, SigFox etc.

- Either to Private server or Cloud platform
- Data management
- Event processing
- Enterprise service
- Data Routing and analys

IoT Networking Communication System

What Is Needed For A "Real" IoT Network Comm System

The Embedded Communication Agent must offer

1. **Scalability** to manage 1000s of nodes vs.10s
2. **Ability to monitor end-to-end**
devices across heterogeneous networks, including multi hop
3. **Control & Configure**
resource constrained devices across communication networks
4. **Adaptive OTA** rollout for device regardless of bandwidth and battery operation
5. **Flexible API** for both Cloud-enabled OEMs, and smaller customers needing full support
6. **Self provisioning** Apple home kit, thread, mbed, Alljoyn, OIC, etc.
7. **Small Footprint** communication agent density to accommodate very small MCUs
8. **IP Based** communication protocols

Internet as a Top Security Concern

Heartbleed, Shellcock, Poodle, Anthem... What's next?



Shodan: The Scariest Search Engine on the Internet

By David Goldman, @DavidGoldmanCNN 1:41 p.m. ET | April 8, 2015

Shodan navigates the Internet's back channels. It runs 24/7 and collects information on about 500 million connected devices and services each month. **Countless traffic lights, security cameras, home automation devices & heating systems, connected to the Internet & easy to spot.**

Shodan searchers have found **control systems for a water park, a gas station, a hotel wine cooler and a crematorium.** Cybersecurity researchers have even located **command and control systems for nuclear power plants and a particle-accelerating cyclotron** by using Shodan.



The biggest risk to a successful proliferation of IoT Edge Nodes is **how much thinking, effort and resources developers are willing to invest in security** when they define and design their product.

Wireless Products Overview

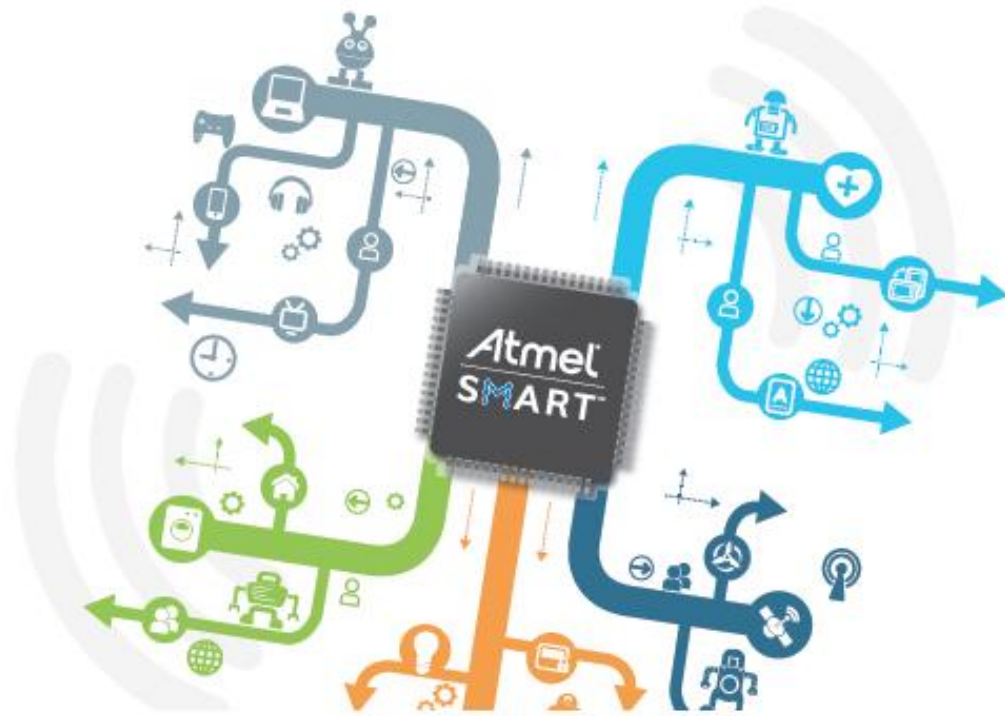

802.15.4 Flash MCU and Transceivers

Cortex M0+ with 2.4Ghz 802.15.4 Transceiver

- **Memories**
 - 64KB/128KB/256KB Flash
 - 8K/16K/32KB SRAM
- **Peripherals**
 - 4-SERCOM Interfaces
 - I²C, SPI, and USART
 - 4x16 bit timers
 - 4-Ch 12-Bit ADC
 - Analog Comparator
- **Sleep Power Consumption**
 - <150µA/MHz active (CoreMark®)
 - <4µA with RTC and Full RAM retention
- **Key features**
 - HW AES
 - Automatic external FEM control, Antenna Diversity
 - Capacitive Touch HW engine (PTC)
 - Integrated 32KHz crystal
 - Ranging engine
- **Package Options**
 - 32pin 5x5mm, 48pin 7x7mm

Link Controller	SAMR21
CPU Core	Cortex-M0+ @ 52MHz
Max PHY rate	Up to 2Mbps
Frequency	2.4GHz
Stacks	BitCloud, Contiki, OpenWSN Coming: mBED, Thread, iControl
Applications	Lighting, Sensor Networks, Home Automation, ESL
Interfaces	SPI, UART
Tx/Rx peak	18mA/9.2mA @ 3.0V
Tx Pout	+4dBm
Rx Sensitivity	-101dBm
Sleep Mode	<4uA (RTC+RAM)
Package	6x6 QFN48 5x5 QFN32
Power Supply	1.8V – 3.6V
Temp Range	-40 to +125°C

Enabling Connectivity in Embedded Systems

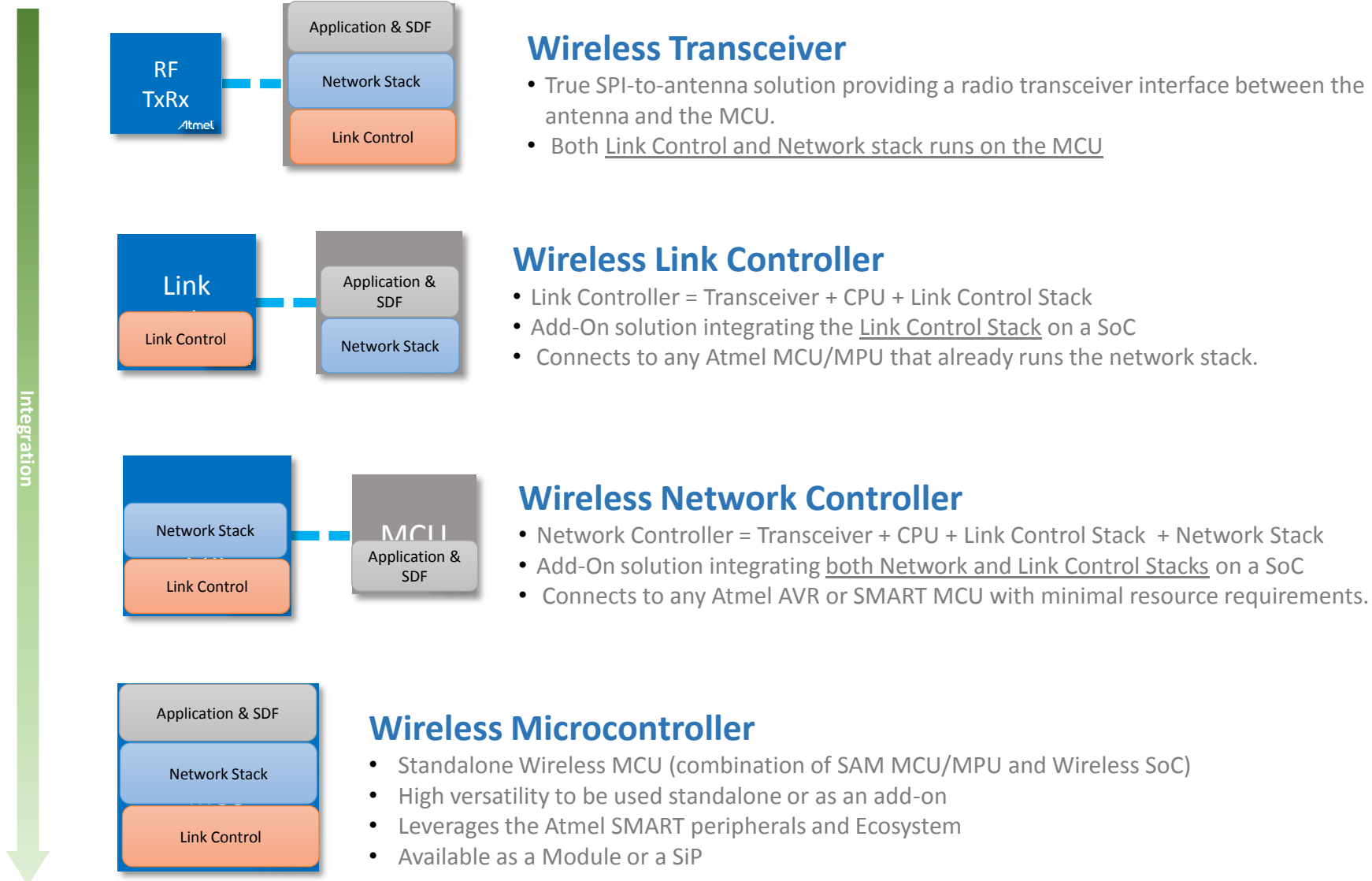

Wi-Fi Link/Network Controller Series

802.11b/g/n and Combo BT4.0 Low Power SoCs

- Best in the industry link budget for **Extended range** IoT use cases
- **Lowest peak current** during Tx and Rx for power constrained applications
- State of the Art **WiFi/BLE combo** with advanced co-existence engine
- **WLCSP package offer** for small form factor integration
 - 802.11bgn SoC: **3x3mm**
 - 802.11bgn/BT4.0: **4.1x4.1mm**
- Available as System in Package with **4Mb Serial Flash**
 - Allows to run TCP/IP and/or BLE stacks on-chip
 - Support for **On-Chip OTA firmware upgrade**
 - Lowers requirements on Host MCU to a 4KB Flash and 1KB RAM API
- **Availability:** Sampling Now.

Link Controller	WILC1000 WINC1500	WILC3000 WINC3400
CPU core	APS3 @ 40MHz	APS3 @ 40MHz
Standards	802.11 b/g/n 1x1	802.11 b/g/n 1x1, BT 4.0 (HS, LE)
Max PHY rate	72Mbps	72Mbps
Frequency	2.4GHz	2.4GHz
Stacks	WEP, WPS, WPA2 Wi-Fi STA/AP/Direct	WEP, WPS, WPA2 Wi-Fi STA/AP/Direct BT 4.0 HCI
Crypto. Acceleration	-	AES-128, SHA-256, RSA
Applications	IoT, Audio/Video	IoT, Audio/Video
Interfaces	SPI, UART, I2C	SPI, UART, I2C
Tx/Rx (dBm)	+20dBm/-91dBm	+20dBm/-91dBm (WiFi) +10dBm/-95.5dBm (BT)
Tx/Rx peak (mA)	172mA/55mA	250mA (WiFi) 52mA (BT)
Package	5x5mm QFN 3x3mm 56WLCSP	6x6mm QFN 4.2x4.2 92WLCSP
Temp Range	-30 to +85°C	-30 to +85°C

WILC1000 / WINC1500 Block Diagram

Available Sept 22nd
5x5 mm QFN
3.1x3.1mm WLCSP56



- **IEEE 802.11 b/g/n Single Chip SOC**

- Integrated RF Transceiver, PA, TR Switch, PMU, Modem, and MAC and flash for various stacks and OTA

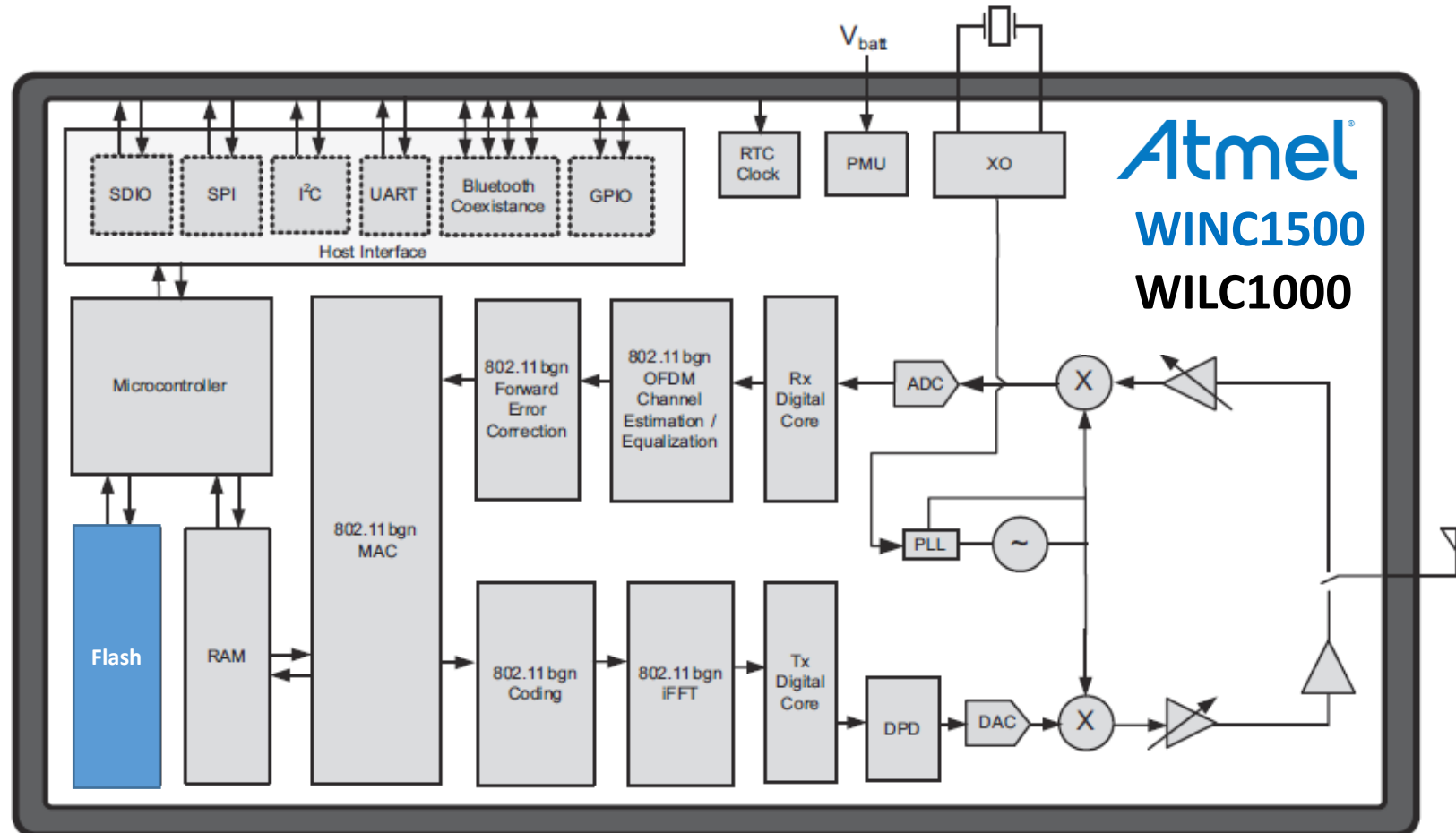

BLE 4.1 SoC Link Controller and MCU

- **Ultra low power BLE SoC**
 - Cortex-M0 based Standalone MCU (SAMB11) or Companion Link Controller (BTLC1000) to a Host MCU
 - Dual mode Slave/Master (up to 8 slaves)
 - Integrated Transceiver, Modem, MAC, PA, TR Switch, and PMU
- **Power Consumption:**
 - Rx: <4mA @3V
 - Tx: <3mA @3V
 - Sleep: <1uA (RTC + 8KB RAM Retention)
 - Lowest advertisement current in market
- **ARM Cortex M0 32 bit processor**
 - 128kB embedded islanded RAM (3x32KB, 2x16KB)
 - 128kB embedded ROM
 - 256KB Stack Flash option (SAMB01 6x6 QFN48 only)
 - Multiple low power sleep modes
- **Peripherals**
 - GPIO (wake up and interrupt)
 - ADC, and PWM analog I/Os
 - RTC, XO and optional fully integrated sleep oscillator
- **Security:** AES-128 & SHA-256 HW encryption
(Secure OTA, Link Encryption on top of BLE)

BLE SoC	BTLC1000	SAMB11
CPU Core	Cortex-M0 @ 26MHz	Cortex-M0 w/256KB flash
Max PHY rate	1Mbps	1Mbps
Frequency	2.4GHz	2.4GHz
Stacks	Self Contained GATT and GATT-based profiles BT Smart 4.1	Self Contained GATT and GATT-based profiles BT Smart 4.1
Applications	Wearable, IoT	Wearable, IoT
Interfaces	SPI, UART	SPI, UART
Tx/Rx peak (mA)	<3/4mA @ 3.0V	<3/4mA @ 3.0V
Tx Pout	-30dBm to +4dBm	-30dBm to +4dBm
Rx Sensitivity	-95dBm	-95dBm
Sleep Mode	<1uA	<1uA
Package	4x4mm QFN32 2.2x2.1mm WLCSP	6x6 QFN48
Power Supply	1.8V – 4.3V	2.3V – 3.6V
Temp Range	-40 to +85°C	-40 to +85°C

BTLC1000 Block Diagrams

ES Sample on May / MP on August
4x4 32QFN 32L
2.2x2.1mm WLCSP56



ES Sample on May / MP on August
6x63 QFN 48L



- **Ultra-Low Power Bluetooth® SMART (BLE 4.1) System**
 - Integrated MCU, Transceiver, PA, TR Switch, PMU, Modem, MAC

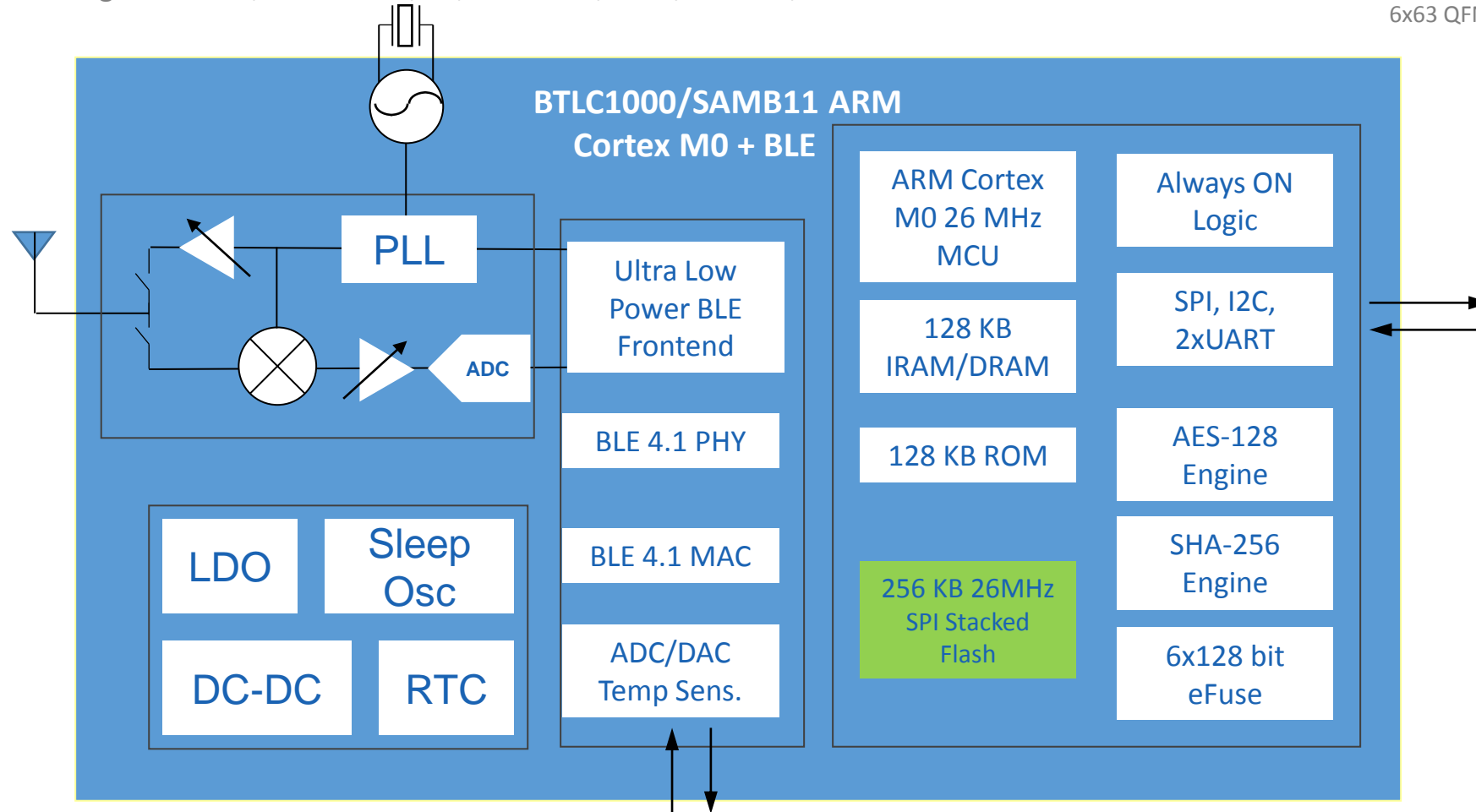

WiFi & BLE Modules List-up

Part Name	Standard	Antenna/UFL	Sample
ATWILC1000-MR1100A	Single 802.11b/g/n 2.4G	-	Now
ATWILC1000-MR110PA	Single 802.11b/g/n 2.4G	PCB type	Now
ATWILC1000-MR110UB	Single 802.11b/g/n 2.4G	UFL	Middle of May, 2015
ATWILC1001-MR1100A	Single 802.11b/g/n 2.4G, FEM	-	Now
ATWINC1500-MR210PA	Single 802.11b/g/n 2.4G, 4Mb Flash	PCB type	Now
ATWINC1500-MR210UB	Single 802.11b/g/n 2.4G, 4Mb Flash	UFL	Middle of May, 2015
ATWINC1510-MR210PB	Single 802.11b/g/n 2.4G, 8Mb Flash	PCB type	Middle of May, 2015
ATSAMW25H18-MR210PA	Single 802.11b/g/n 2.4G, SAMD21	PCB type	Now
ATSAMW25H18-MR510PB	Single 802.11b/g/n 2.4G, 8Mb Flash, SAMD21, Crypto	PCB type	Middle of May, 2015
ATBTLC1000-XPRO	BT 4.1(BLE)	Chip type	ES(June of 2015), MP(August of 2015)
ATBTLC1000-MR110CA	BT 4.1(BLE)	Chip type	ES(June of 2015), MP(August of 2015)
ATSAMB11G18A-MR210CA	BT 4.1(BLE)	Chip type	ES(June of 2015), MP(August of 2015)

SAMW25 Series – Secure Edge Node Module

The Secure Edge Node on a Module

- **Standalone Edge Node Module**

The SAMW25 is a certified module used as a turn key Add-On module adding Wi-Fi Connectivity to an existing system.

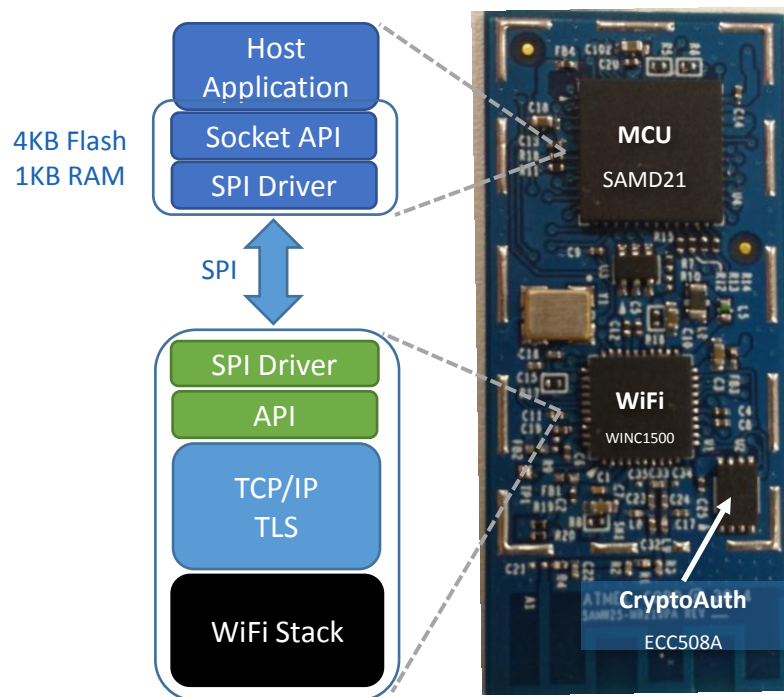

	SAMW25H18 -MR210PA	SAMW25H18 -MR510PB
Wi-Fi SoC	WINC1500	WINC1510B
Embedded Host MCU	SAMD21	SAMD21
Single Band 802.11n	✓	✓
WPS, WPA/WPA2 Supplicant	✓	✓
TCP/UDP, DNS, HTTP/HTTPS, TLS	✓	✓
CryptoAuthentication (ECC508A)	-	✓
Antenna Design	PCB	PCB
OTA Upgrade	✓	✓
Dimensions	33.8mm x 14.9mm	
Pin out	51 castellations	
Certification	FCC, IC, ETSI, TELEC	
Sampling	Now	Middle of May,2015
Availability (MP)	Middle of May,2015	-

SAMW25 Series – Positioning

The Secure Edge Node on a Module

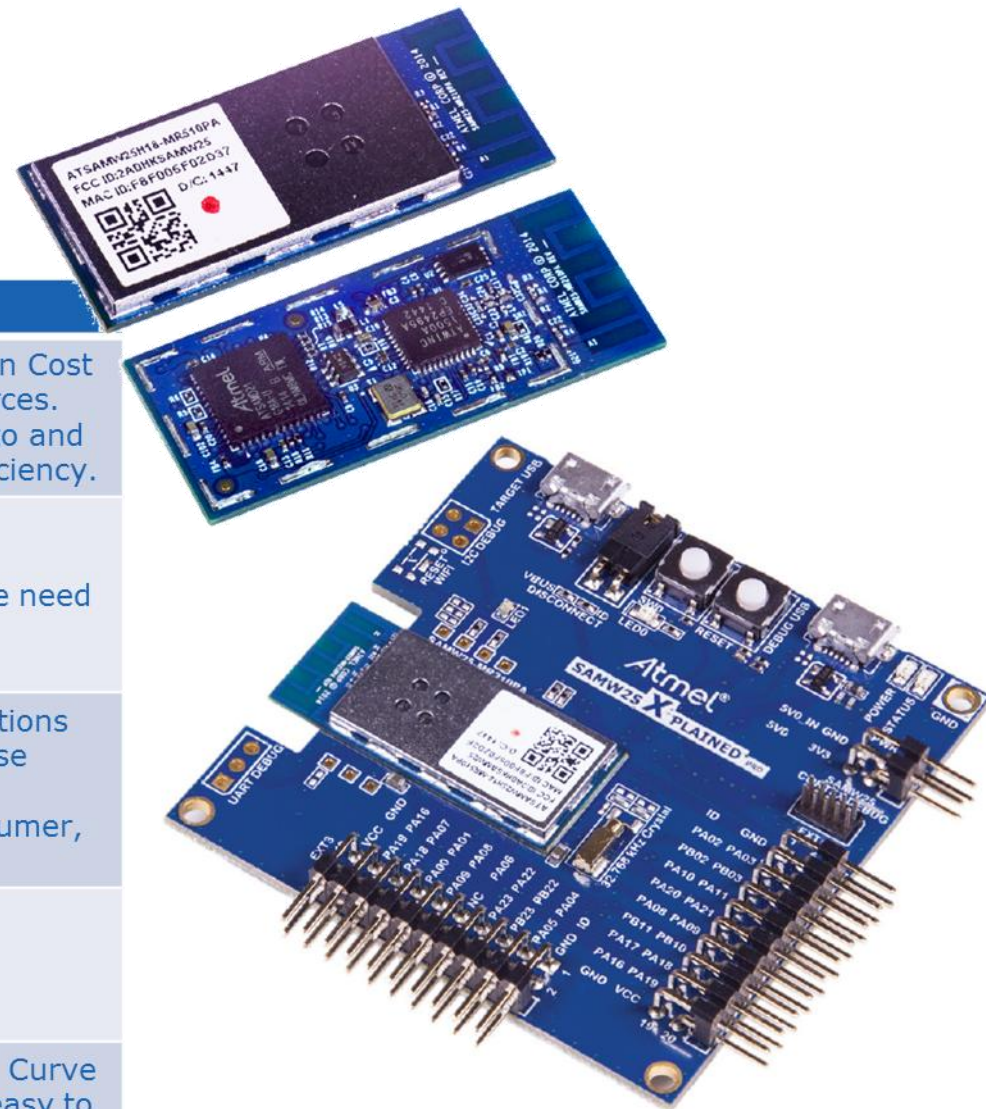

Highlight	Benefits to Customers
Self-contained Certified module.	<ul style="list-style-type: none"> Accelerating time to market by saving certification Cost of over \$30K and significant lab approvals resources. Single technology provider for MCU, Wi-Fi , Crypto and Module reducing support time and increasing efficiency.
WINC1510B Low Power Wi-Fi Network Controller	<ul style="list-style-type: none"> The lowest power consumption Wi-Fi chip for IoT market providing years of operation Integrated Network stack protocol eliminating the need for CPU to run protocol and providing Network Transport layer security.
SAMD21 Atmel's most versatile CortexM0+ MCU	<ul style="list-style-type: none"> Can operate completely host-less in most applications A rich set of peripherals, flexibility and ease-of-use combined with low power consumption Ideal for a wide range of home automation, consumer, metering and industrial applications.
8 Mbit internal Flash memory with OTA firmware upgrade	<ul style="list-style-type: none"> Supporting MDNS and Customized Networking Protocols.
Crypto Auth ECC508	<ul style="list-style-type: none"> The first crypto device to integrate ECDH (Elliptic Curve Diffie–Hellman) key agreement, which makes it easy to add confidentiality (encryption/decryption) to digital systems for Internet of Things (IoT) nodes

BTLC1000-XSTK-(ES) Starter Kit

Enabling Smart, Connected IoT Devices

Includes :

- BTLC1000-MR110CA XPRO Wing
- SAMD(L)21 Xplained PRO
- Temp sensor integrated on XPRO
- Atmel Studio Support
- 1 Project Example –more coming
- Onboard JTAG
- Available June with ES silicon
- Available August with MP Silicon



SAMB11-XSTK-(ES) Starter Kit

Enabling Smart, Connected IoT Devices

Includes :

- SAMB11-MR210CA Xplained PRO
- Temp sensor and other sensors integrated on Xplained Pro
- Initially only Keil support
- Atmel Studio Support coming later
- Onboard JTAG
- Available May/June with ES silicon
- Available August with MP Silicon



Zigbee_Module List-up

Part Name	Standard	Antenna/UFL	Sample
ATZB-RF-212B-0-CN	802.15.4 transceiver 900MHz (AT86RF212B)	Chip type / RF Test Port	Now
ATZB-RF-212B-0-U	802.15.4 transceiver 900MHz (AT86RF212B)	UFL	Now
ATZB-RF-233-1-C	802.15.4 transceiver 2.4GHz, FEM(20dBm Output, AT86RF233)	Chip type / RF Test Port	Now
ATZB-S1-256-3-0-C	802.15.4 transceiver 2.4G, AVR 8bit Microcontroller(ATmega256RFR2)	Chip type / RF Test Port	Now
ATZB-S1-256-3-0-U	802.15.4 transceiver 2.4G, AVR 8bit Microcontroller(ATmega256RFR2)	UFL	Now
ATZB-X0-256-4-0-CN	802.15.4 transceiver 900MHz, AVR 8bit Microcontroller(AT86RF212B+ATxmega256A3U)	Chip type / RF Test Port	Now
ATZB-X0-256-3-0-C	802.15.4 transceiver 2.4G, AVR 8bit Microcontroller (AT86RF233+ATxmega256A3U)	Chip type / RF Test Port	Now
ATSAMR21B18-MZ210PA	802.15.4 transceiver 2.4G, Cortex-M0+, AES128, OTA (SAMR21G18)	PCB Antenna	ES Now. MP Q3
ATSAMR21G18-MR210UA	802.15.4 transceiver 2.4G, Cortex-M0+, AES128, OTA(SAMR21G18)	2xUFL	ES Now. MP Q3
ATSAMR21G18-MR212PA	802.15.4 transceiver 2.4G, Cortex-M0+, FEM, AES128, OTA(SAMR21G18)	PCB Antenna / UFL	ES July. MP Q4

SmartConnect 15.4 module Roadmap

	ATSAMR21B18-MZ210PA	ATSAMR21G18-MR210UA	ATSAMR21G18-MR212PA
Target Customer/Market	Lighting	General purpose ranging external antenna	General purpose/Industrial
Form Factor	Module 14.7 mm x 19.7 mm	Module 20mmx33mm	Module 20mm x 33mm
Microcontoller	SAMR21E18 Cortex M0+	SAMR21G18 Cortex M0+	SAMR21G18 Cortex M0+
RF Output Power	+ 4dBm (IC)	+ 4dbm(IC)	+ 10dbm
Radio Transceiver family	AT86RF233	AT86RF233	AT86RF233
FEM (PA/LNA)	No	No	YES(SE2438T)
Rx Sensitivity	-99dBm (IC)	-99dBm(IC)	-103dBm(FEM)
RF Operating Frequencies	2.4GHz	2.4GHz	2.4GHz
Antenna	PCB Antenna	2 x u.FL connector	Pcb trace + u.FL connector
OTA Upgrade	Yes	Yes	Yes
Security	AES128	AES128	AES128
Available user module IO	5	32	32
Host Interface	SPI, UART	SPI, UART	SPI, UART
Crypto memory	--	ECC508	--
Operating Voltage	1.8 – 3.6v	1.8 – 3.6v	1.8–3.6v
Temperature Range	-40°C – + 125°C	-40°C – + 85°C	-40°C – + 85°C
Certification and Compliance	FCC, CE, IC, RoHS	FCC, CE, IC, RoHS	FCC, CE, IC, RoHS
Sample Availability	April 2015	May 2015	July 2015

SAMR21 ZLL-EK reference platform

Dedicated for Wireless Lighting Control

Feature highlights:

- Micro USB for Serial connection (main test interface for software) and power
- External SPI NOR Flash Micron M25P40
- Small LCD and RGB Led connected to PWM
- Joystick button (Left, Right, Up, Down, Center) plus one separate button.
- Touch interface
- Digital pins of SAMR21 available on one or more Debug' connectors
- Second UART available on 6 pin connector for standard FTDI TTL-232R-3V3 USB2Serial cable
- Antenna diversity:
 - On-board antennas
 - Switched coax connectors to disable on-board antenna.
- Demo software + documentation in progress
- **PN# SAMR21ZLL-EK**
- **Available** in March 2015



IBM Cloud Demo with SAMD21+ WINC1500+ IO1



Atmel SMART : SAMD21-XPRO Evaluation kit.
[Atmel SAMD21 Xplained Pro](#)
SAMD21J18A microcontroller
8 Mbit Serial Flash
32.768kHz crystal
Embedded Debugger



Atmel WINC1500-XPRO Wi-Fi extension board.
[Atmel WINC1500 Xplained Pro](#)
Wi-Fi STA, Wi-Fi hotspot., Wi-Fi Direct client (P2P).
IEEE 802.11 b/g/n.
Transport Layer Security.
Network protocols.



Atmel ATIO1-XPRO Sensor extension board.
[Atmel IO1 Xplained Pro](#)
ADC: Light Sensor and PWM signal filtered into ADC
TWI: Temperature sensor w/ EEPROM
SPI: microSD card holder + microSD card



Atmel OLED1-XPRO extension display board.
[Atmel OLEDIO1 Xplained Pro](#)
128 x 32 Pixels
Controlled by 4-wire SPI interface
Three LEDs, Three Buttons

IBM Cloud Demo with SAMD21+ WINC1500+ IO1

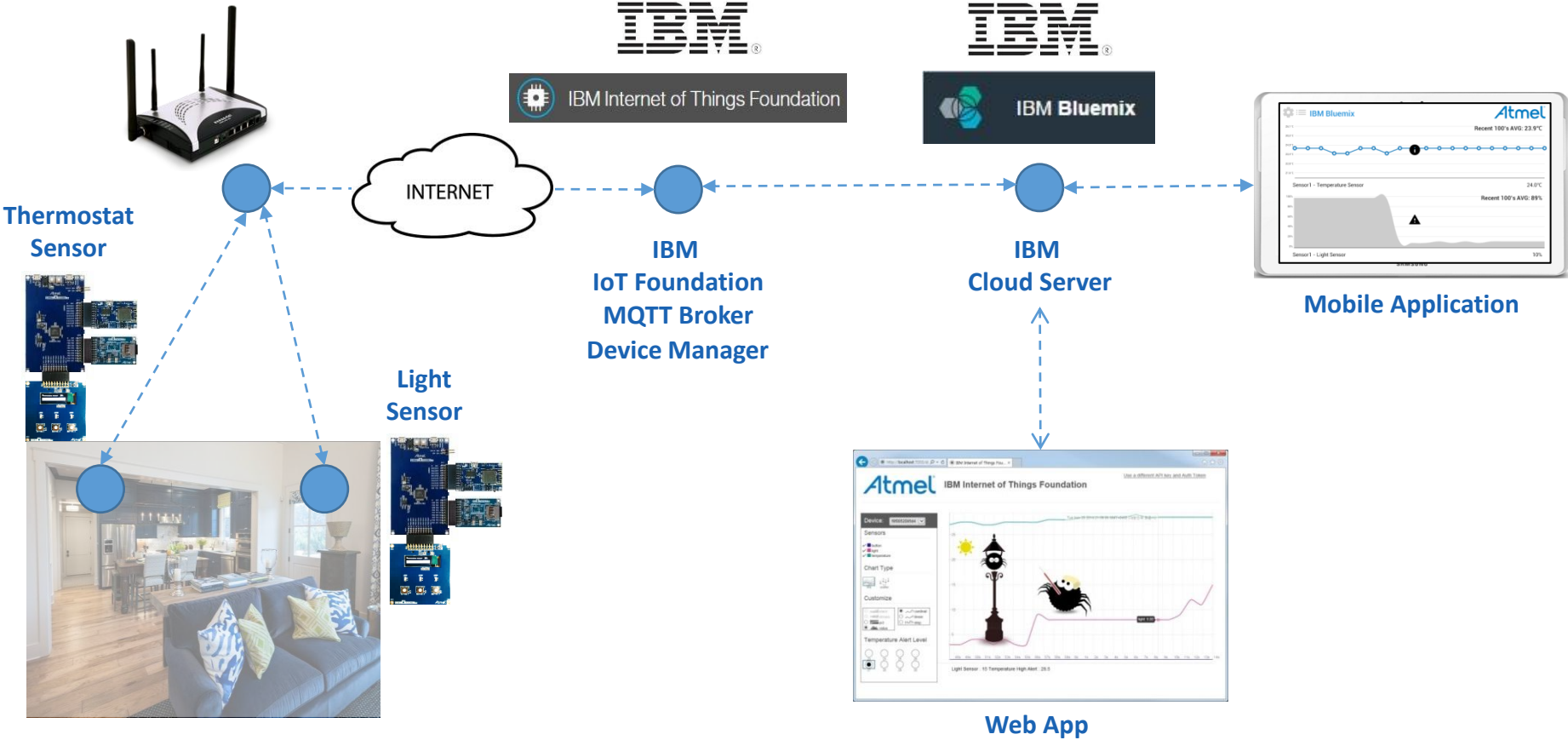

SAMD21+WINC1500

- Cooker
- Refrigerator
- Air Conditioner
 - Boiler
 - Washer
- Water pure
- Remote Control
 - Wearable
 - Induction
 - Oven



DoorCAM Demo with SAM4S-WPIR + WINC1500

SAM4S-WPIR-RD with WINC1500

- This example demonstrates how transmits image data thru the SAM4S with WINC1500.
- Capture the image thru Image Sensor When PIR sensor detected motion. then, image data will be transmitted to "android example application" over UDP.

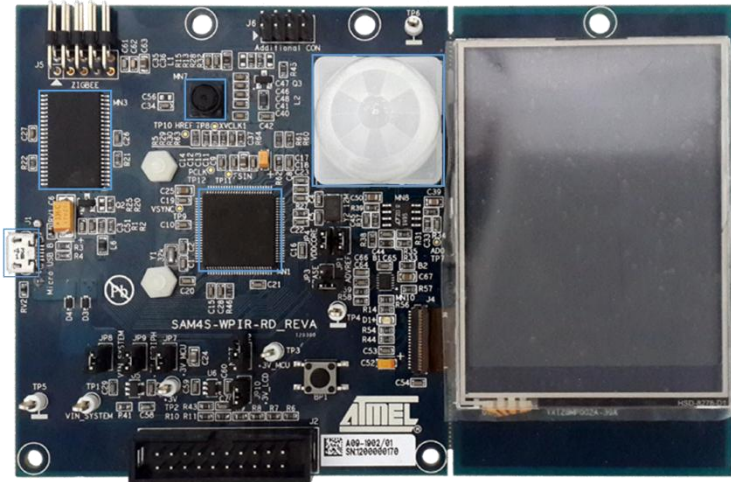

Atmel SMART : SAM4S-WPIR Evaluation kit.

SAM4S microcontroller
2 MB Serial Flash
160KB SRAM
32.768kHz crystal
Embedded Debugger

Image Sensor



- The CMOS image sensor, OV7740 from OmniVision, used in this reference design is a low-complexity, low-cost, low-power, yet powerful sensor. It supports VGA (640x480) at up to 60 fps and QVGA (320x240) at up to 120 fps.

PIR sensor



- The PIR sensor (RE200B from Nicera) chosen for the reference design is a general purpose dual element. This model satisfies user's cost reduction needs, keeping most dual element type performances at reasonable levels.

WINC1500



Atmel WINC1500-XPRO Wi-Fi extension board.

[Atmel WINC1500 Xplained Pro](#)

Wi-Fi STA, Wi-Fi hotspot., Wi-Fi Direct client (P2P).
IEEE 802.11 b/g/n.
Transport Layer Security.
Network protocols.

DoorCAM Demo with SAM4S-WPIR + WINC1500

SAM4S-WPIR-RD with WINC1500

- Transmitting captured images over UDP.

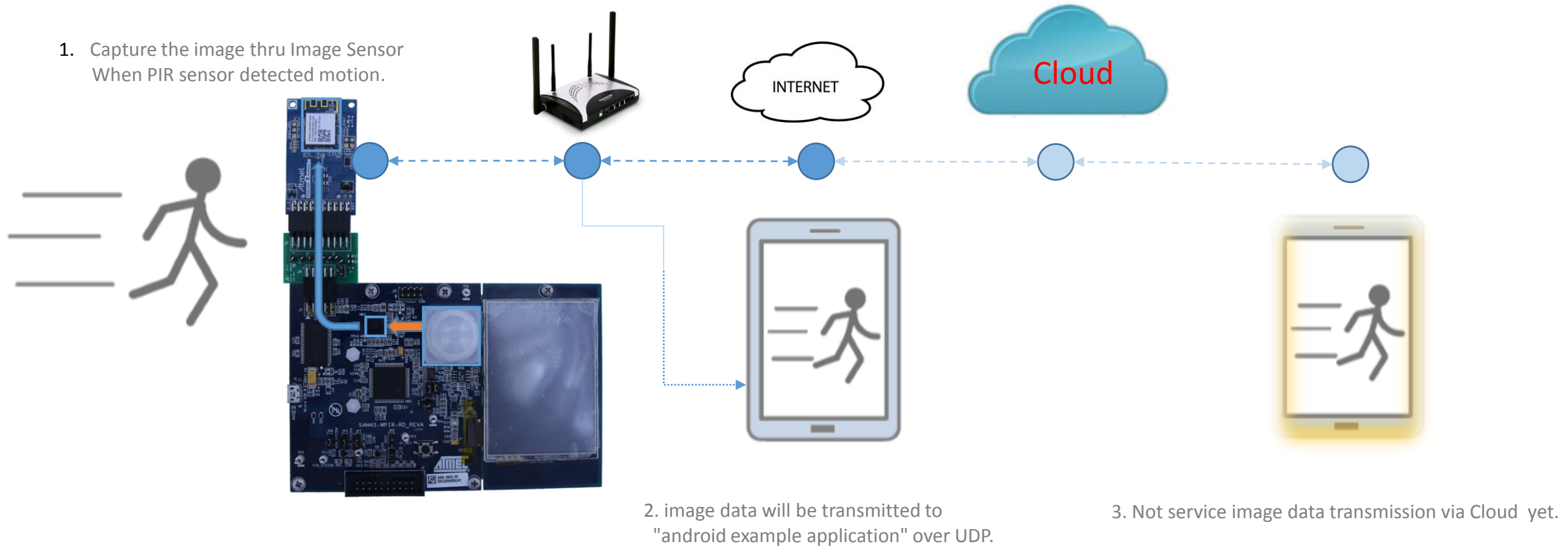

SAM4S+WINC1500



- DoorCAM
- Home Security
- Wireless Medical Device
- Wireless Microscope & Telescope
- Wireless Beauty Device



WiFi Demo with SAMA5 Xplained & WILC1000 SD PRO

SAMA5D3 Xplained



- SAMA5D36 Cortex-A5 Microprocessor
- 256MBytes DDR2
- 256MBytes NAND Flash
- LCD connectors
- Dual Ethernet (GMAC + EMAC) with PHY and connectors
- Three USB connectors (2 Host + 1 Device)
- 1x SD/eMMC and 1x MicroSD slots
- Expansions headers, Arduino R3 Shield compatible
- Power measurement straps

WILC1000 SD PRO



- IEEE 802.11 b/g/n
- Single spatial stream in 2.4GHz ISM band
- Wi-Fi Direct and Soft-AP support
- Supports IEEE 802.11 WEP, WPA, WPA2 Security
- Supports China WAPI security
- Superior MAC throughput via hardware accelerated two-level A-MSDU/A-MPDU frame aggregation and block acknowledgement
- On-chip memory management engine to reduce host load
- SPI, SDIO host interfaces

WiFi Demo with SAMA5 Xplained + WILC1000 SD PRO

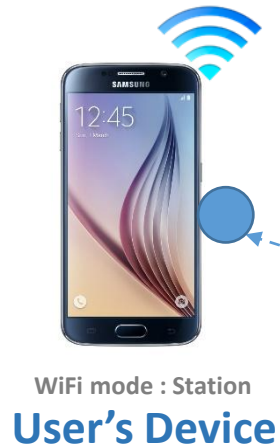

Router

- Linux Kernel Version 3.10
- This set works as opened Soft AP named "WILC1000_AP" as soon as system boots.
- This create a forwarded bridge via ethernet port connected to external networks.



Ethernet



WILC1000 client device

- Linux Kernel Version 3.10
- Used QT Web browser for Internet.
- This set connects to AP named "WILC1000_AP" as soon as system boots.

SAM4S+ WINC1500



- Gateway
- Finger scanner
- Iris recognition system
- WiFi Speaker
- Wearable
- WallPad
- Photo Printer
- BlackBox



Tiny Gateway Demo with ZigBee SAMR21 + WINC1500 + IO1



SAMR21 XPRO

- Low power Microcontroller using the 32bit ARM® Cortex®-M0+
- An integrated ultra-low power 2.4GHz ISM band transceiver
- 32 & 48pin packages with up to 256KB Flash, 32KB of SRAM
- 250kb/s data rate
- -99dBm RX Sensitivity and TX Output Power up to +4dBm
- Antenna Diversity and TX/RX Control



WINC1500

Atmel WINC1500-XPRO Wi-Fi extension board.

[Atmel WINC1500 Xplained Pro](#)

- Wi-Fi STA, Wi-Fi hotspot., Wi-Fi Direct client (P2P).
- IEEE 802.11 b/g/n.
- Transport Layer Security.
- Network protocols.



[Atmel IO1 Xplained Pro](#)

Atmel ATIO1-XPRO Sensor extension board.

[Atmel IO1 Xplained Pro](#)

- ADC: Light Sensor and PWM signal filtered into ADC
- TWI: Temperature sensor w/ EEPROM
- SPI: microSD card holder + microSD card

Tiny Gateway Demo with ZigBee SAMR21 + WINC1500 + IO1

- This example demonstrates how transmits temperature data thru the SAMR21 with ZigBee(BitCloud).
- Temperature data thru ZigBee wireless then, Temperature data will be transmitted to "android example application" over UDP (via WINC1500).

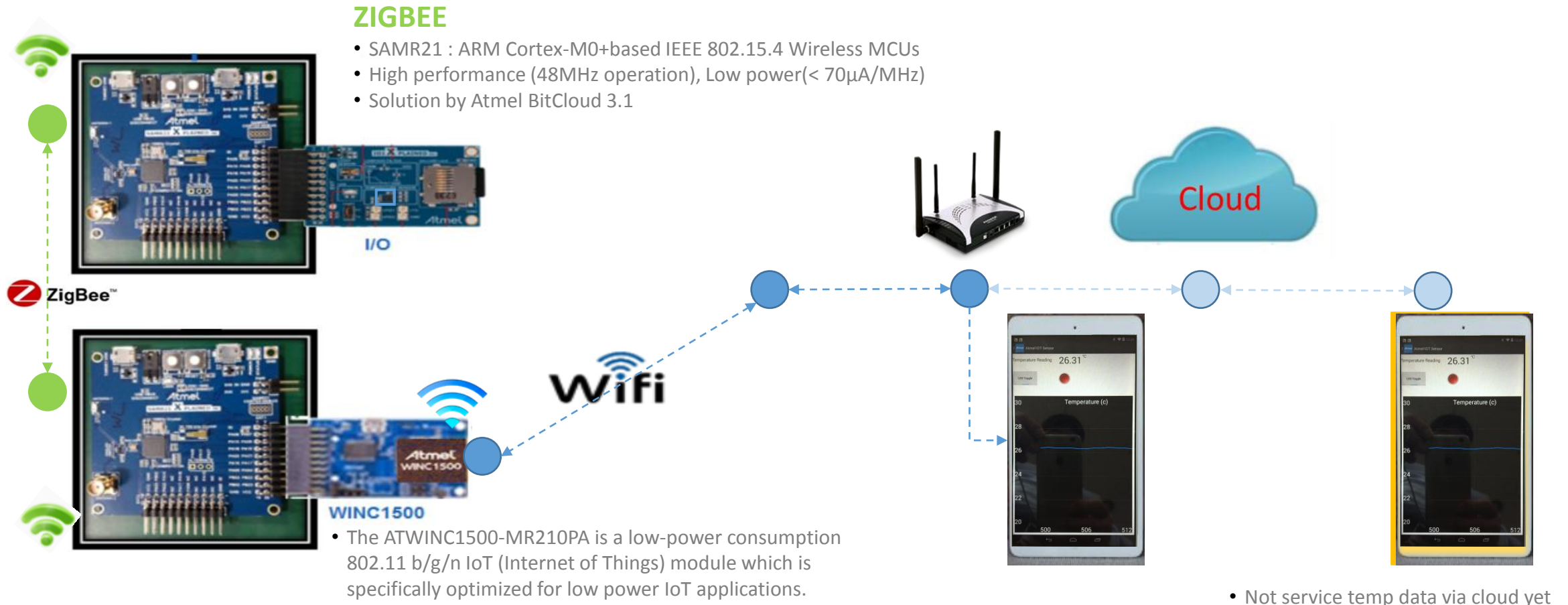

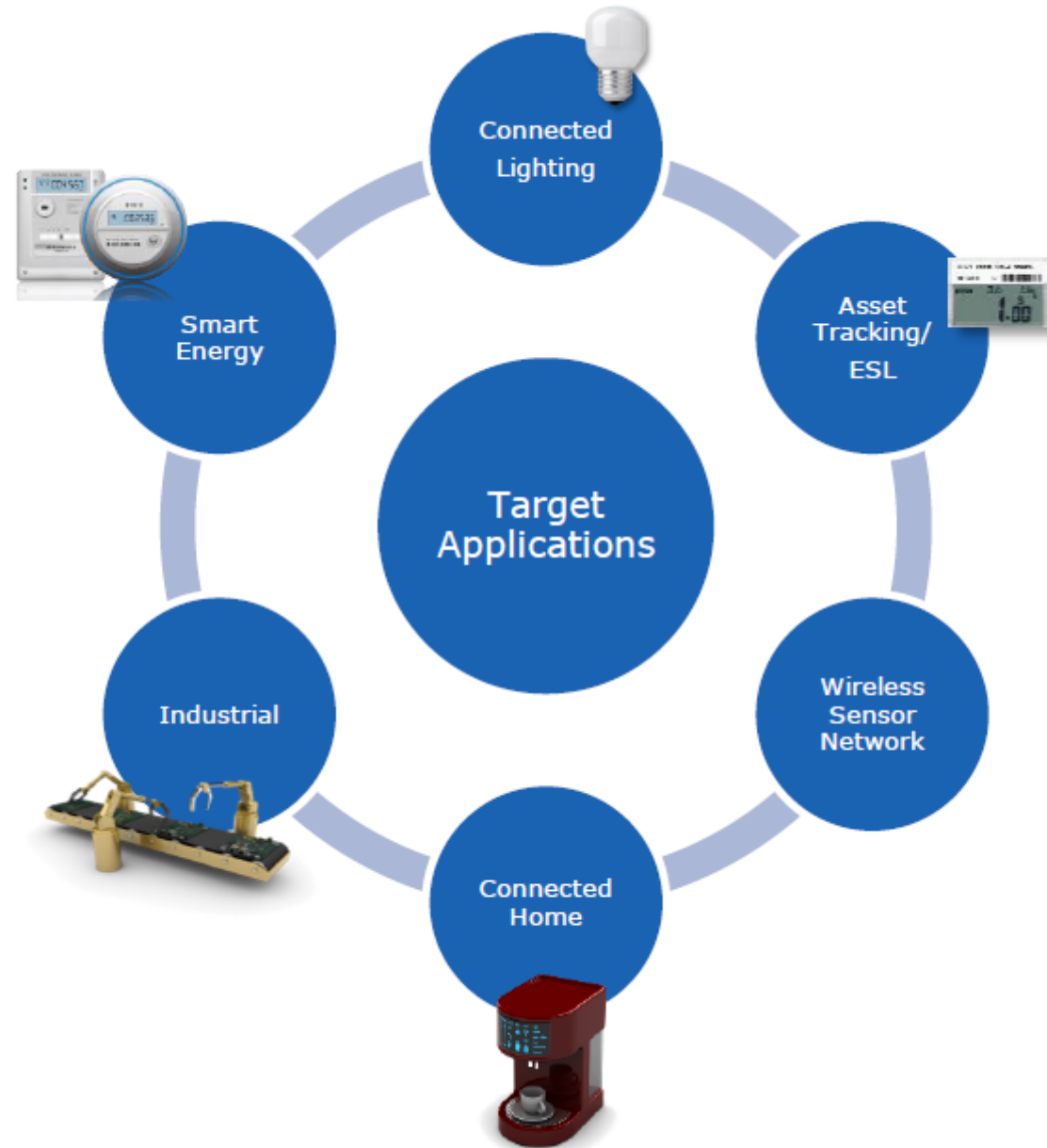

Real Security for IoT & Beyond...

Crypto Solution

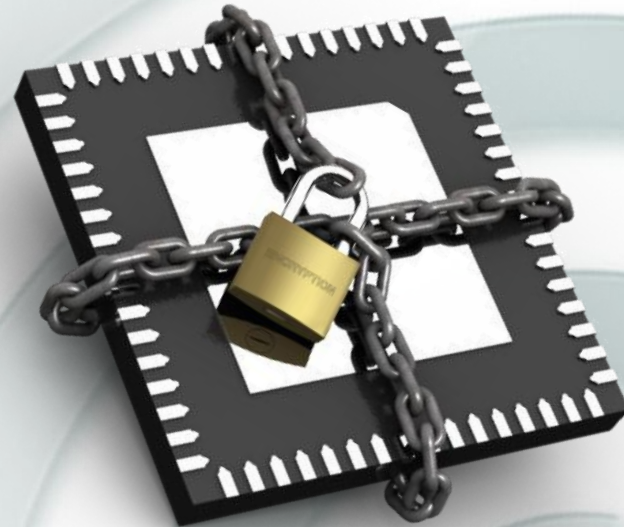

Easy to find unprotected nodes!



SHODAN

EXPOSE ONLINE DEVICES.

WEBCAMS. ROUTERS.
POWER PLANTS. IPHONES. WIND TURBINES.
REFRIGERATORS. VOIP PHONES.

[TAKE A TOUR](#) [FREE SIGN UP](#)



All software is vulnerable



*Software can see into memory.
Don't put keys there!*

PASSWORD

***you need special hardware designed
to protect secrets***

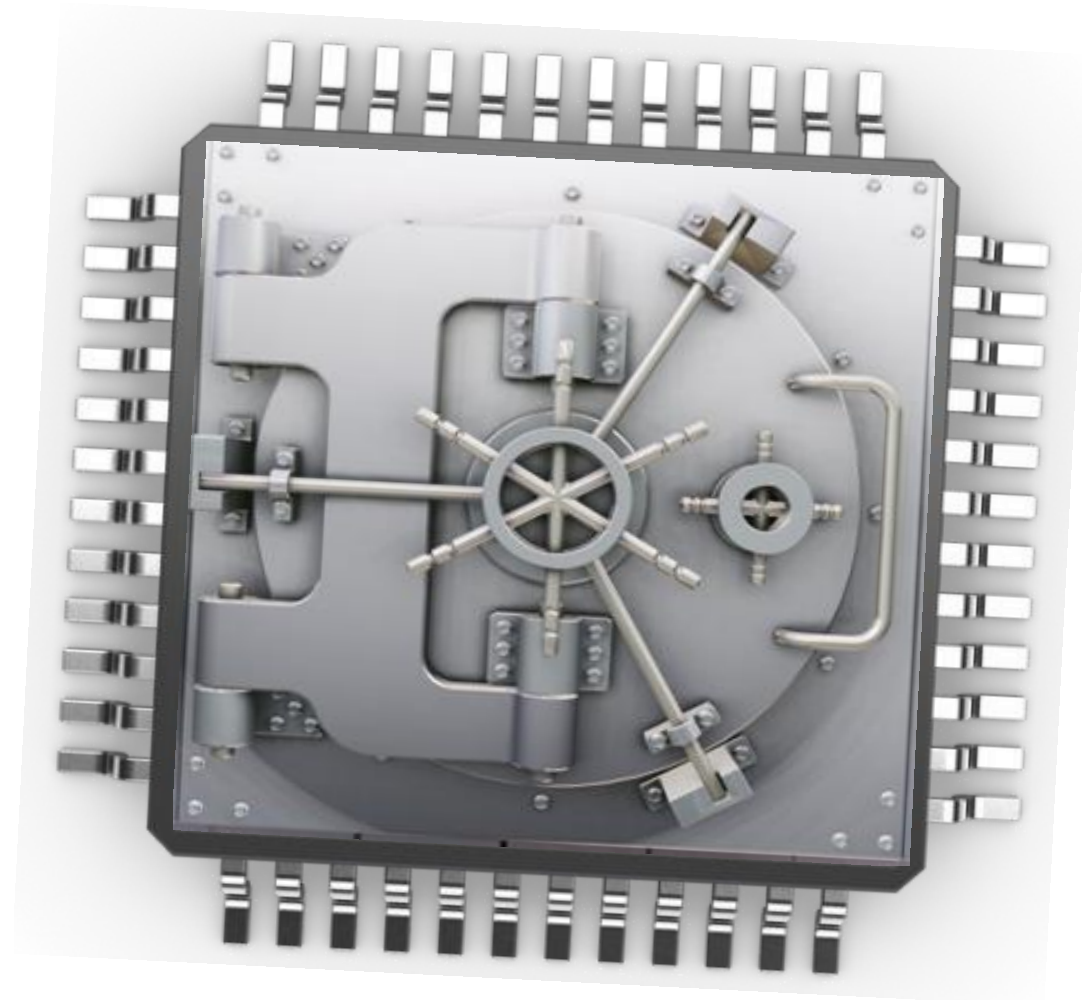

Crypto Product

	ATSHA204A	ATECC508A	ATECC108A	ATAES132A
Description	Secure authentication and validation device	High speed PKI crypto engine with secure key storage. FIPS186-3 Elliptic Curve Digital Signature Algorithm (ECDSA) for ECC Sign-Verify		High-security, Serial EEPROM providing authentication and confidential nonvolatile data storage.
ECDH		Runs FIPS SP800-56A Elliptic Curve Diffie-Hellman Algorithm		
Function(s)	Authentication	Authentication, and key exchange for confidentiality and data integrity (when used with AES)	Authentication	Encryption / Authentication
Data Sheet Status	Public	NDA		Public
Authentication	SHA , HMAC (Symmetric)	SHA, HMAC, (Symmetric), ECC (Asymmetric)		AES-CCM (Mutual) (Symmetric)
Crypto Algorithms	SHA256	SHA256, ECCP256	SHA256 ,ECC-P256,ECC-B283,ECC-K283	AES128
Key Length	256	SHA=256; ECC=P256	SHA=256; ECC=P256; =K283, =B283	128
Secure boot	SHA	SHA/ECC		-
Key Exchange	SHA	SHA		AES-CCM
Key Authorization	-	SHA, ECC		AES
Key Creation	SHA / Random	SHA / Random		Random
Command Authorization	-	-		AEC-CCM
Encrypted Read/Write	SHA / XOR	SHA / XOR		AES-CCM

Atmel Solution

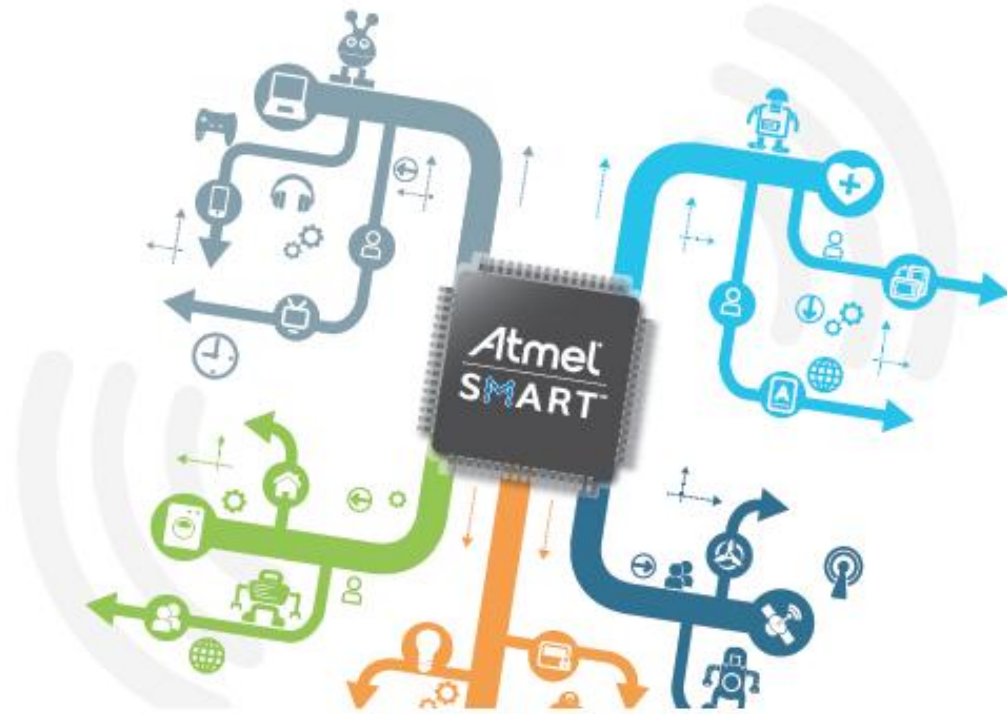

Atmel Value Added System Level Smart Connect Solution

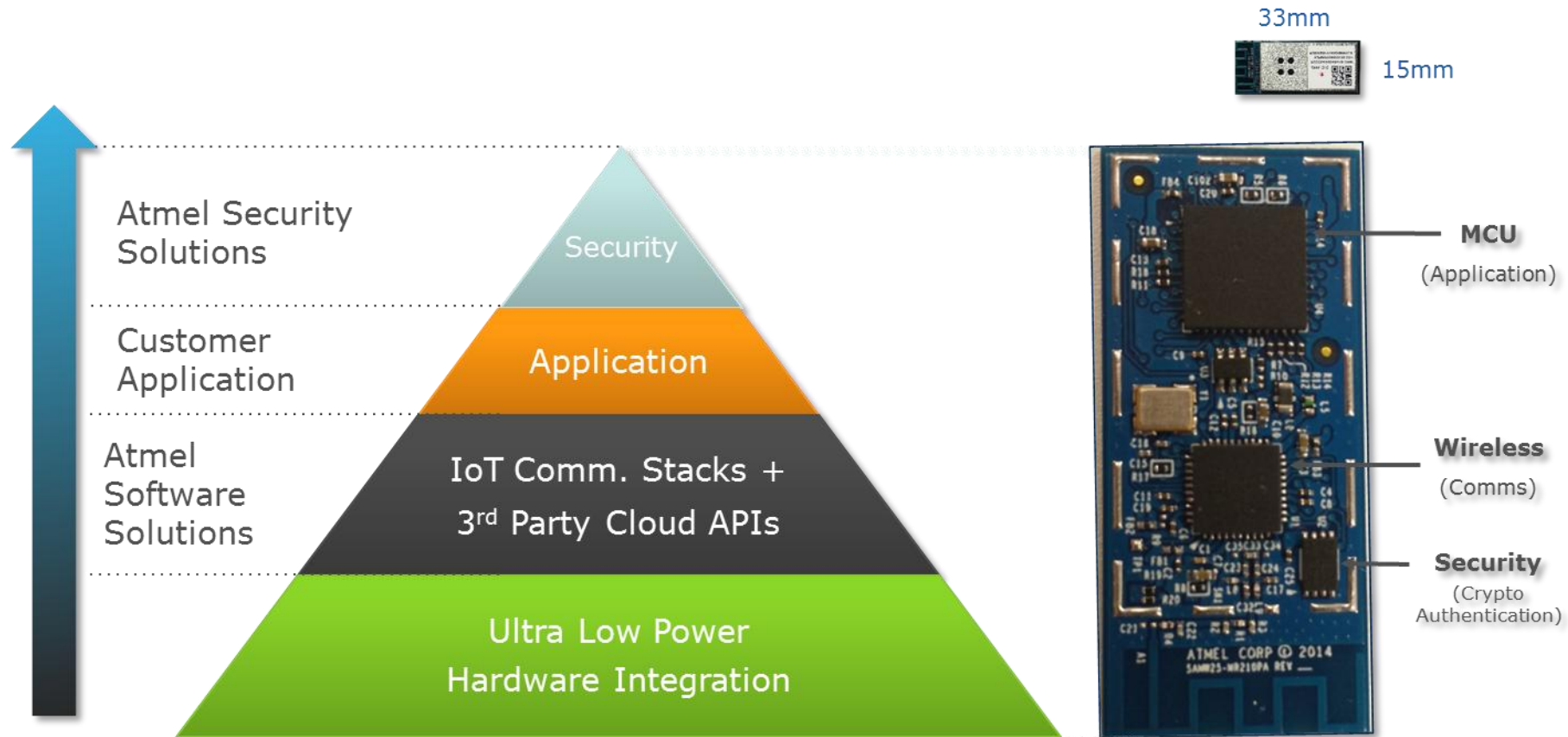

Creating a System Solution for Easy Adoption

Atmel
SmartConnect

