

The World Leader in High Performance Signal Processing Solutions



Working with Digital Isolators in Motor Control Applications

Nicola O'Byrne
Mark Cantrell
October 15th 2014

Agenda

Section 1

Motor Control Architectures & Approaches

Section 2

Influencing Factors on Architecture/ System Build

Section 3

Using *iCoupler*[®] Technology in Motor Drive Systems

Motor Control Architectures & Approaches

General Motor Control Signal Chain

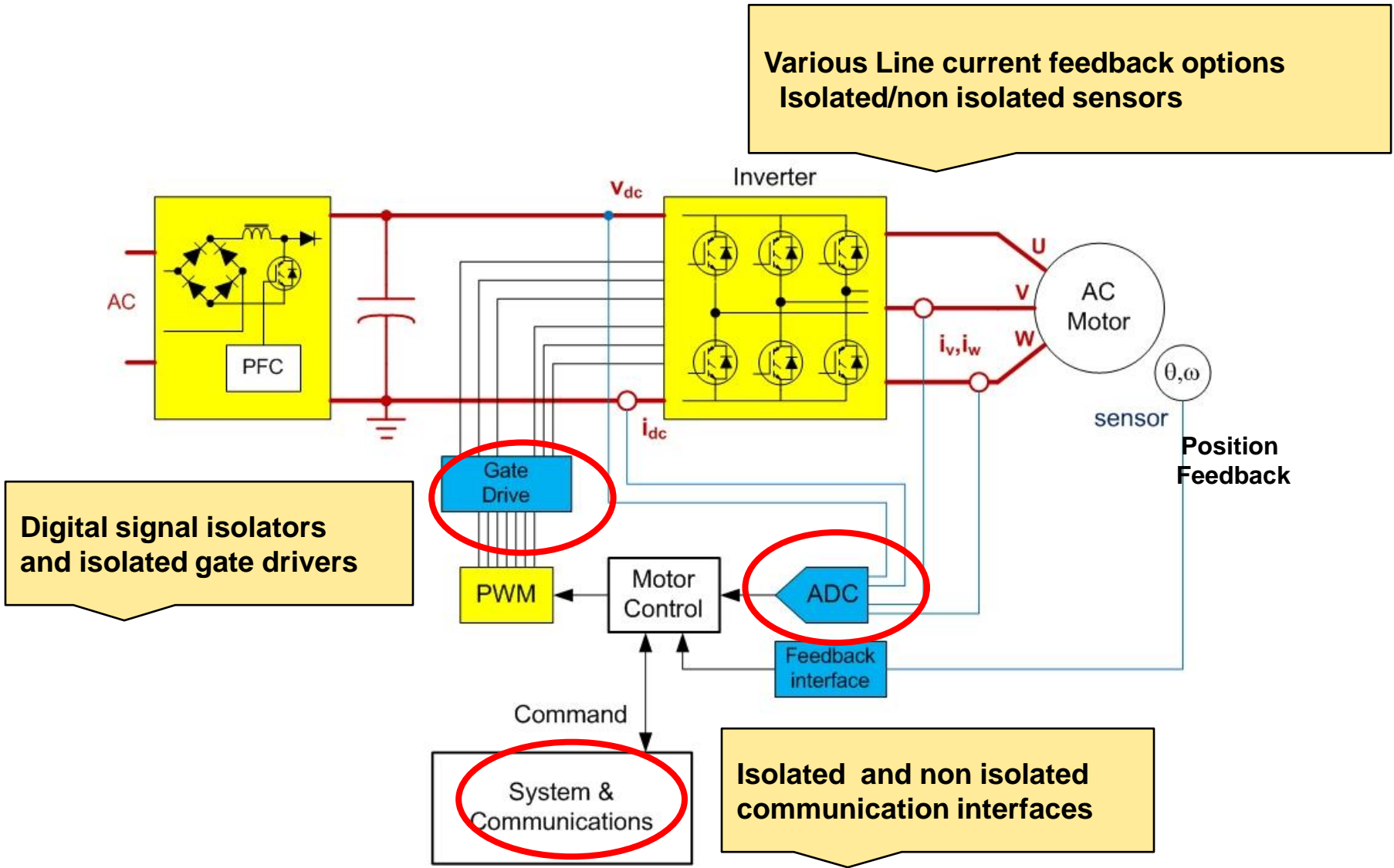

Power and Grounding issues

- ◆ Isolation is the key challenge
- ◆ Power ground is LIVE
- ◆ Need to isolate users
- ◆ Where to isolate?
- ◆ Low end drives may connect CONTROL to power ground and isolate at the comms layer using cheap optos – can tolerate slower comms.
- ◆ High performance drives will isolate the control board because of the fast comms.
- ◆ Higher power systems need to isolate the control board because of power board switching noise.
- ◆ Many implications

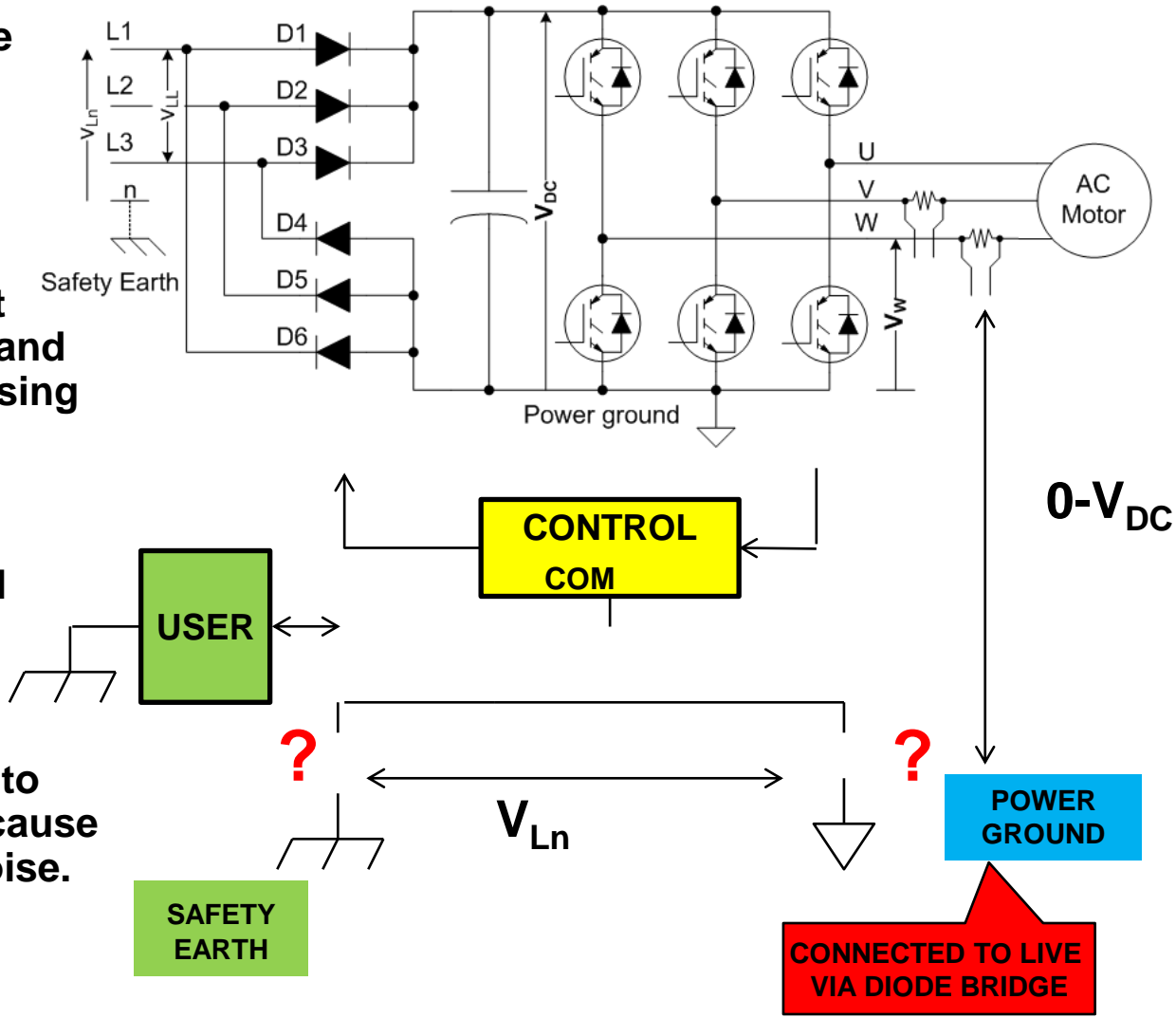

Isolation Challenges in Industrial Motor Control Applications

- ◆ **Very high CMMR required**
 - **Common mode voltages of 600V or more switching at > 20kHz with > 25V/ns rise times**
 - **Current feedback signals to be recovered**
 - ◆ Sensor choice plays a key role
 - ◆ Shunt sensors, need to recover small signals in noisy environment, < 50mV at 12 bit resolution.
 - ◆ Isolated sigma delta modulator output is a 3.3V single bit stream > 10MHz
 - ◆ Analog signal isolated is an even bigger challenge
 - **Communications signals need high speed and fidelity**

- ◆ **The isolated current feedback and gate drive nodes are connected to inverter outputs and require very high robustness**
 - **Inverter voltages have a very high dV/dt**
 - ◆ 25V/ns for IGBT inverters
 - ◆ rising to 100V/ns for newer power switches
 - **Surge and transient voltages injected on motor cables connected directly to output node**
 - **Corruption of the gate drive signal has the potential to destroy the power inverter.**

Architecture Considerations

◆ Why to isolate?

- Safety need vs. Electrical functional vs. data integrity.

◆ Where to isolate?

- Low-end vs. high end - performance
- Single or Dual Processor

◆ Number of isolation layers?

- Insulation Grade
- Adherence to standards
- Nature of isolation at each layer

◆ Most Prevalent isolation nodes: Gate Drive, Phase Current and Bus Voltage

- Impact of Voltage and Current Sensor Choice
 - ◆ Power Rating

Safety and Functional Isolation

- ◆ **Functional isolation protects electronic control circuits from damaging voltages**
 - Isolate high voltage output from control circuits connected to Power_GND.
- ◆ **Safety isolation protects the user from dangerous voltages.**
 - Protects user and electronic circuits.
 - International standards apply.
 - Typically require double insulation barrier.
 - ◆ Single device with two insulating layers
 - ◆ OR two single insulating layer devices in path to EARTH

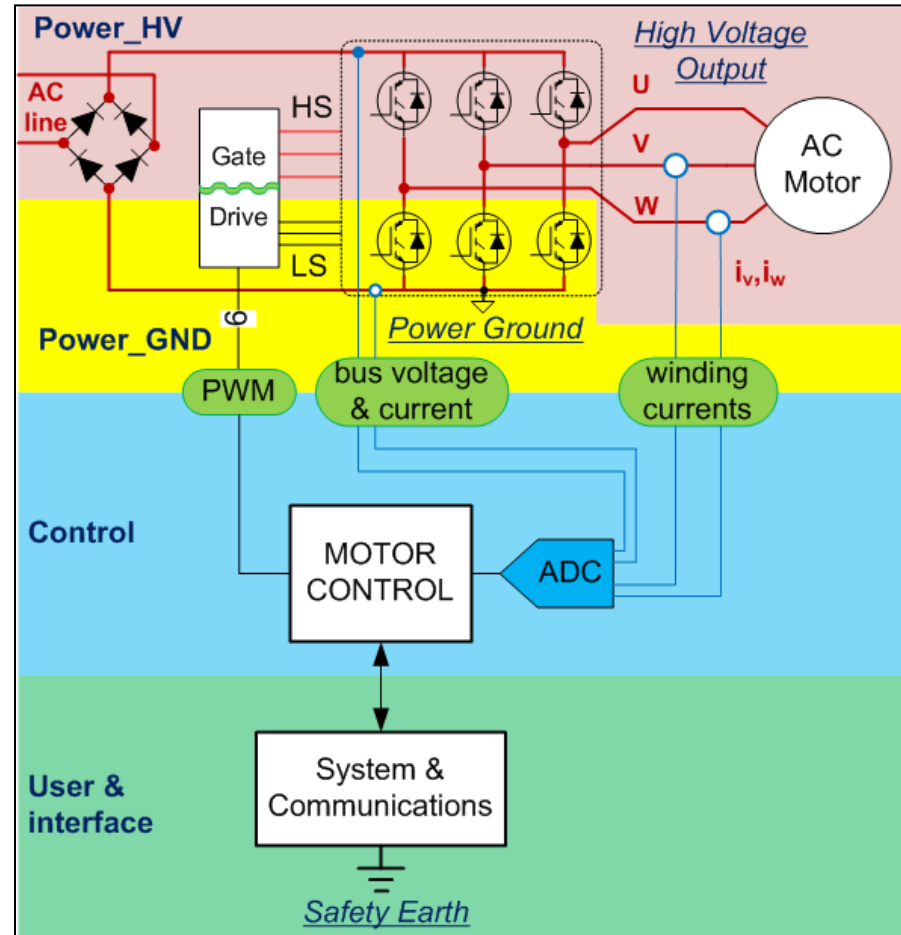

Safety and Functional Isolation

◆ **Functional isolation protects electronic control circuits from damaging voltages**

- Isolate high voltage output from control circuits connected to Power_GND.

◆ **Safety isolation protects the user from dangerous voltages.**

- Protects user and electronic circuits.
- International standards apply.
- Typically require double insulation barrier.
 - ◆ Single device with two insulating layers
 - ◆ OR two single insulating layer devices in path to EARTH

◆ **Isolation options**

- **Isolate Power circuits from the Control and user I/O circuits.**
 - ◆ Common in high end or in 'noisy' high power systems
 - ◆ Required when there is high BW communications between control and communications process

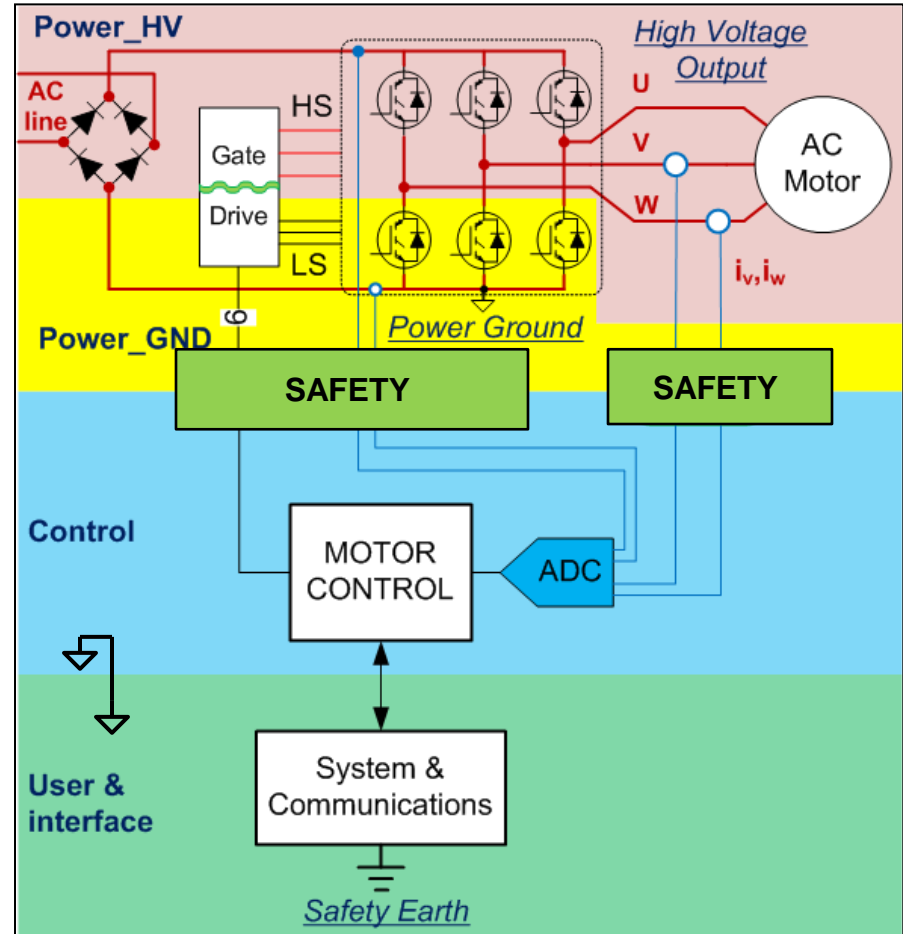

Safety and Functional Isolation

◆ **Functional isolation protects electronic control circuits from damaging voltages**

- Isolate high voltage output from control circuits connected to Power_GND.

◆ **Safety isolation protects the user from dangerous voltages.**

- Protects user and electronic circuits.
- International standards apply.
- Typically require double insulation barrier.
 - ◆ Single device with two insulating layers
 - ◆ OR two single insulating layer devices in path to EARTH

◆ **Isolation options**

- **Isolate Power circuits from the Control and user I/O circuits.**
 - ◆ Common in high end or in 'noisy' high power systems
 - ◆ Required when there is high BW communications between control and communications process
- **Isolate Power and Control circuits from user I/O circuits**
 - ◆ Common in systems that are both low power *and* low end
 - ◆ Simplifies signal isolation when there is limited communications between control and user

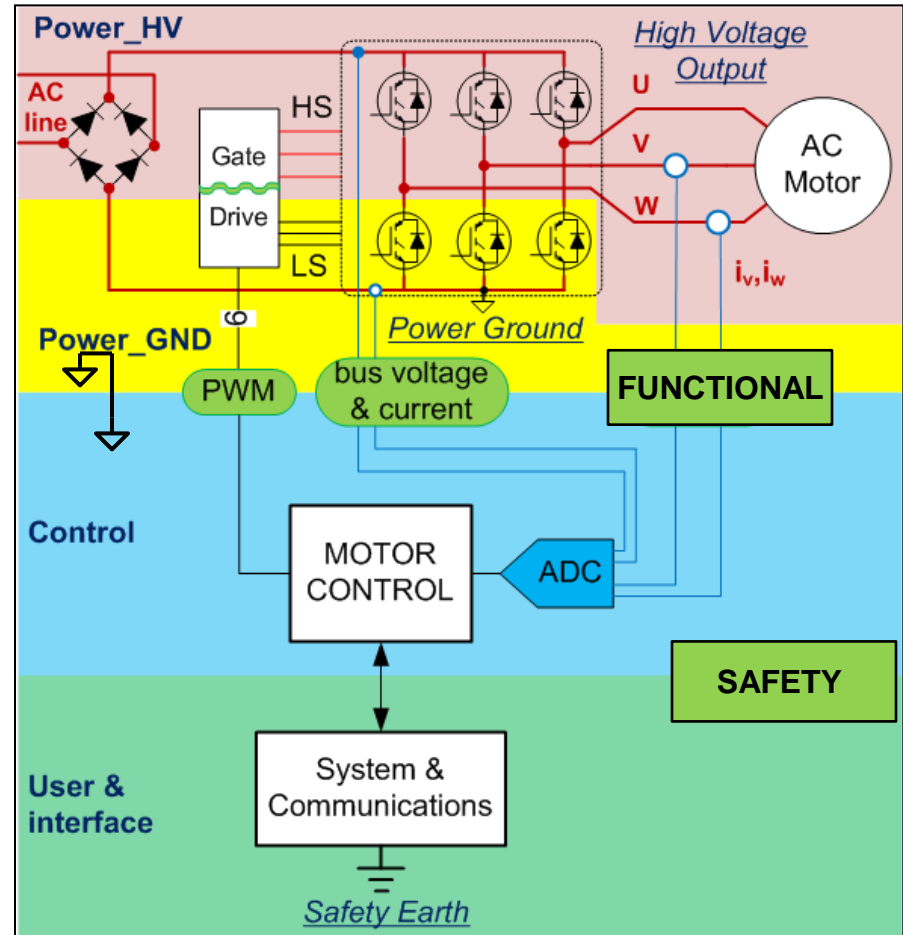

Safety and Functional Isolation

- ◆ **Functional isolation protects electronic control circuits from damaging voltages**

- Isolate high voltage output from control circuits connected to Power_GND.

- ◆ **Safety isolation protects the user from dangerous voltages.**

- Protects user and electronic circuits.
- International standards apply.
- Typically require double insulation barrier.
 - ◆ Single device with two insulating layers
 - ◆ OR two single insulating layer devices in path to EARTH

- ◆ **Isolation options**

- **Isolate Power circuits from the Control and user I/O circuits.**

- ◆ Common in high end or in 'noisy' high power systems
- ◆ Required when there is high BW communications between control and communications process

- **Isolate Power and Control circuits from user I/O circuits**

- ◆ Common in systems that are both low power *and* low end
- ◆ Simplifies signal isolation when there is limited communications between control and user

- **Safety isolation layer may shift to comms layer in mid performance systems**

- ◆ Faster digital isolators, isolated transceivers
- ◆ Allows shrinking of power board, less creepage/clearance, smaller packages.

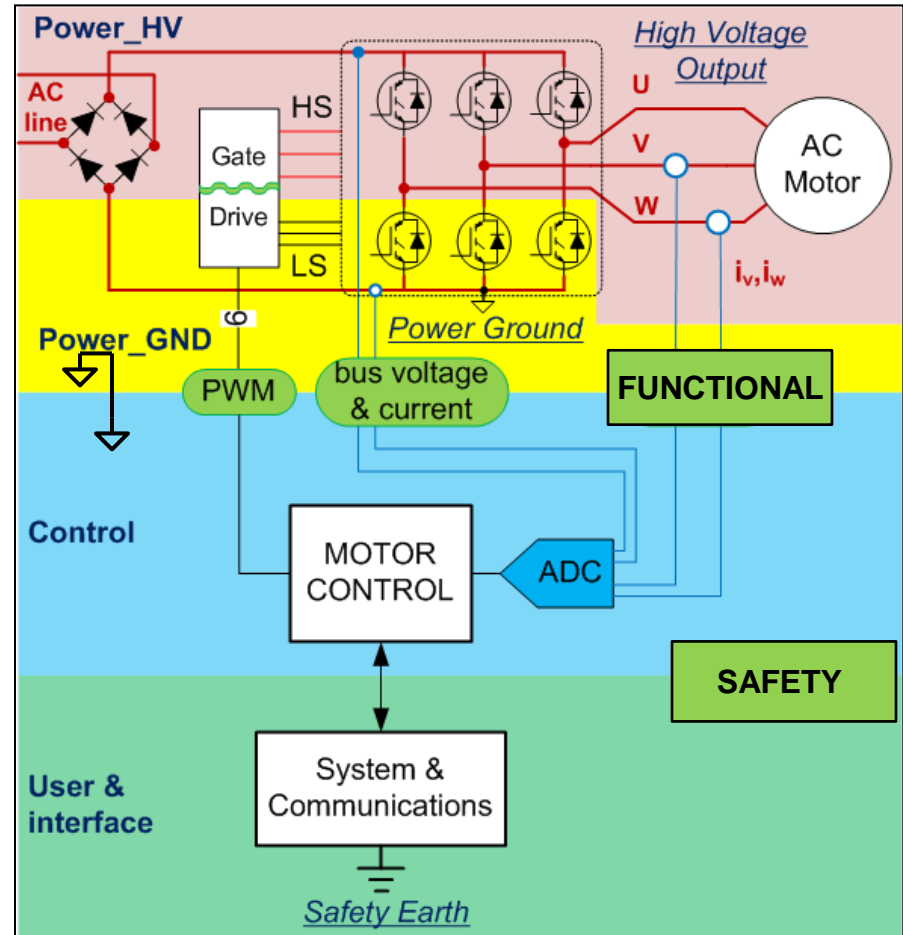

ADI *i*Coupler Digital Isolator Solutions

◆ Isolation Technology

- Supports Multiple Drives (220V/400V/690V)
- Robust and Safe (Functional/Basic/Reinforced)
- Long life > 105°C, 125°C

◆ Isolated Gate Drivers

- Robust and matched timing
- MOSFET/ IGBT, Full and Half Bridge Drivers

◆ Isolated $\Sigma\Delta$ Modulators and Isolated Amps

- 16-bit Isolated Sigma Delta
- Isolated Error Amplifier

◆ Standard Data Isolators

- 1-6 Channels
- High Data rates (>150 Mbps)
- Compact and cost effective

◆ Isolated Communications

- Supports multiple standards
 - ◆ I2C, SPI, RS232, RS485, CAN, USB

◆ *isoPower*[®]

- Isolated DC/DC Converter
- Compact and integrated
- Up to 500mW isolated power

Critical for closed loop MC

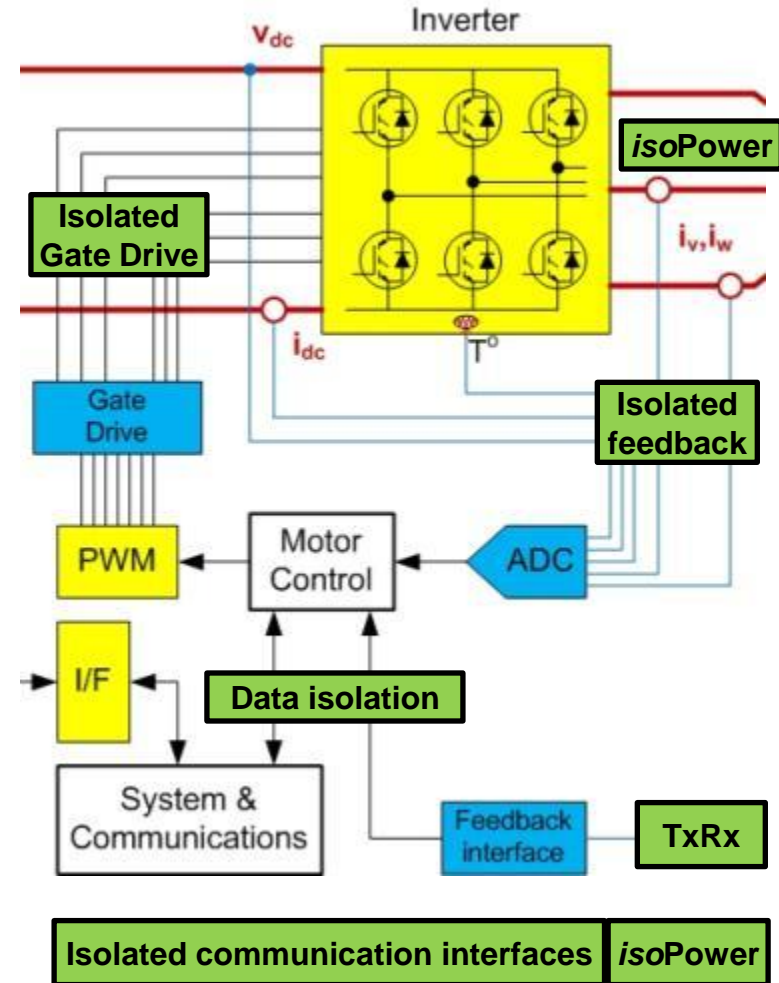

Power Grounding and Current Sensing

Motor control processor ground connected to Power GND.

- Low end drives with simple user interface
- **Functionally** isolated current sensing may be used.

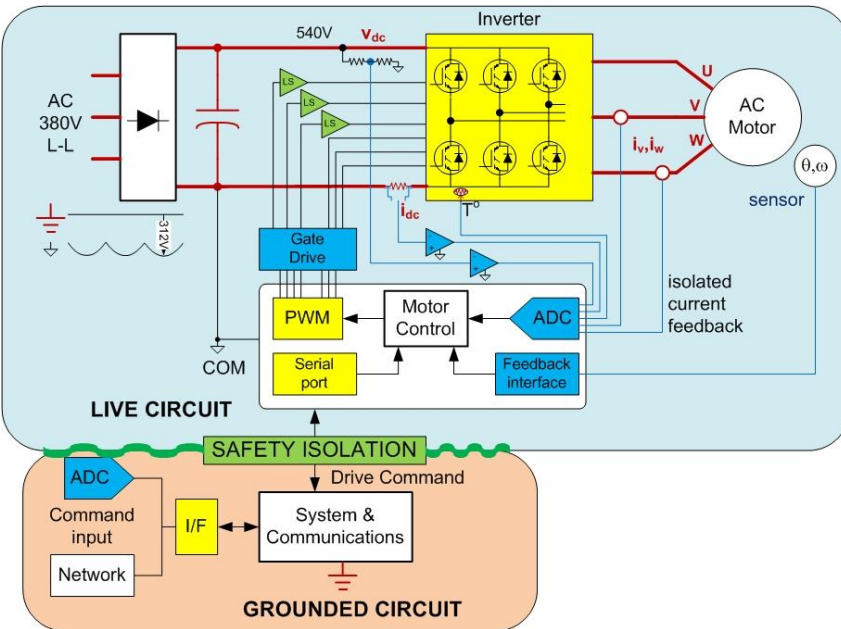

Motor control processor ground connected to Safety Earth.

- High end drives with complex user/communication interface
- **Safety** isolated current sensing **MUST** be used.

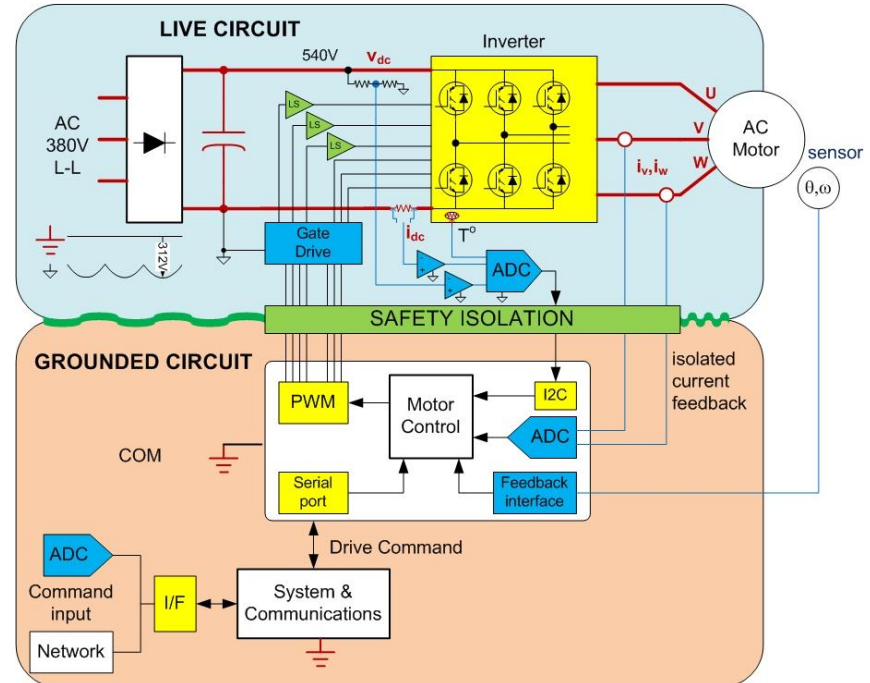

Isolated and non isolated current feedback

- Line current feedback options:**
- Isolated sensor + amp + SAR ADC
 - Isolated sensor + ($\Sigma\Delta$) Mod + SINC3
 - Line shunt + isolation amp + SAR ADC
 - Line shunt + isolating ADC + SINC3 ($\Sigma\Delta$)

Non isolated
Leg OR dc link
shunt + amp + ADC

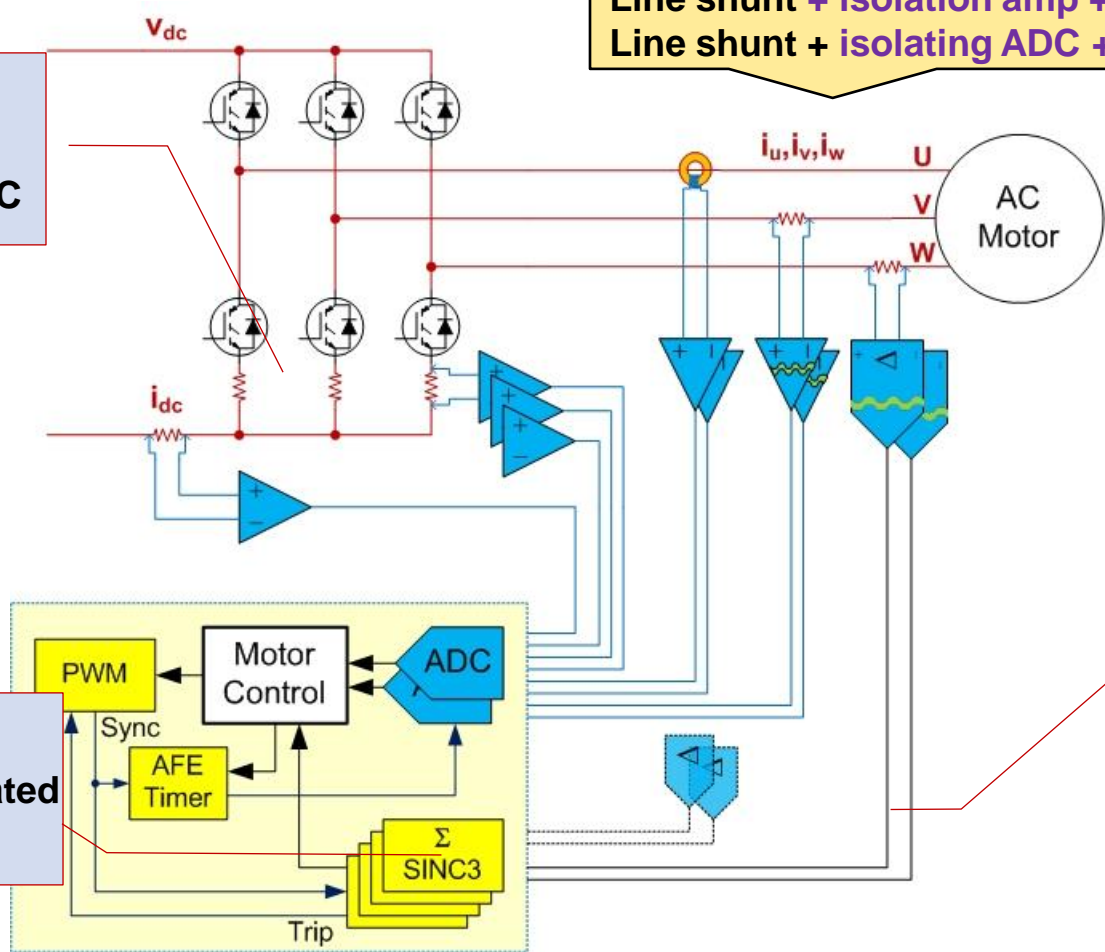

SINC3 filter for
Isolated or non-isolated
 $\Sigma\Delta$ modulators

Non isolated
modulator for
isolated sensor
+ $\Sigma\Delta$ ADC.

Isolated and non isolated current feedback

Line current feedback options:
 Isolated sensor + amp + SAR ADC
 Isolated sensor + ($\Sigma\Delta$) Mod + SINC3
 Line shunt + isolation amp + SAR ADC
 Line shunt + isolating ($\Sigma\Delta$) Mod + SINC3

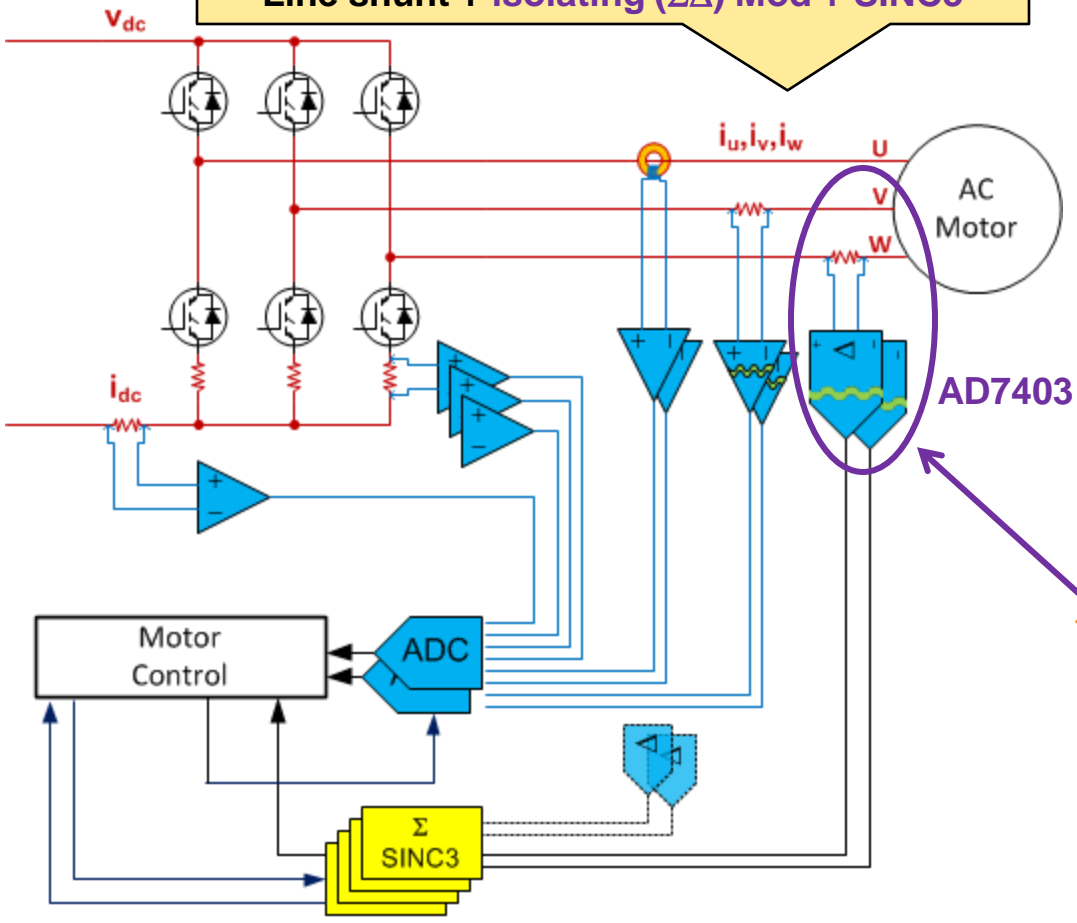

◆ **Shunt current measurement is the preferred approach to measuring high side current in the DC/AC power conversion stage in motor drives.**

- **Shunt Resistor**
 - ◆ Linear, wide BW, no offset, AC/DC.
 - ◆ Cost of PCB insertion lower.
 - ◆ No saturation/hysteresis issues.
 - ◆ Power loss at high currents and no isolation
- **Current transformer**
 - ◆ Isolating
 - ◆ AC only with poor linearity at low current
- **Hall Effect current sensor**
 - ◆ Isolating, DC operation and less expensive than CT
 - ◆ Non linearity and offset drift

- ◆ **Eg. AD7403 Isolated $\Sigma\Delta$ Modulator**
 - High performance $\Sigma-\Delta$ modulator improves the performance of motor drives by reducing torque ripple on the motor shaft
 - The AD7403 enables shunt resistance reduction
 - Increased isolation working voltage ($1250 V_{peak}$) - higher DC-bus voltage.

Control Connected to Power Ground Non-isolated current feedback

'Low power' and Low end

Non isolated
Leg OR dc link
shunt + amp + ADC

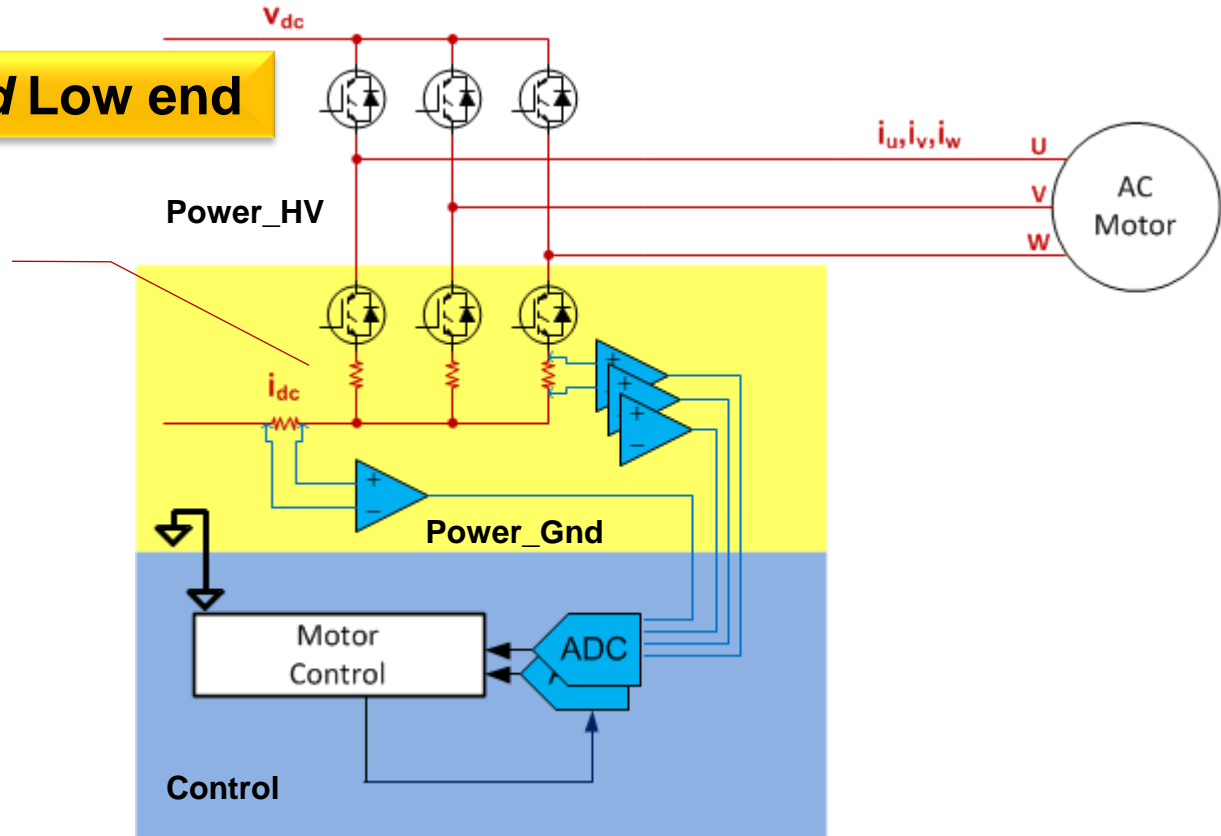

Control Connected to Power Ground Functionally Isolated current feedback

'Higher power' and Low to mid-end

Most 'likely' Line current feedback options:
 Isolated sensor + amp + SAR ADC
 Line shunt + isolation amp + SAR ADC

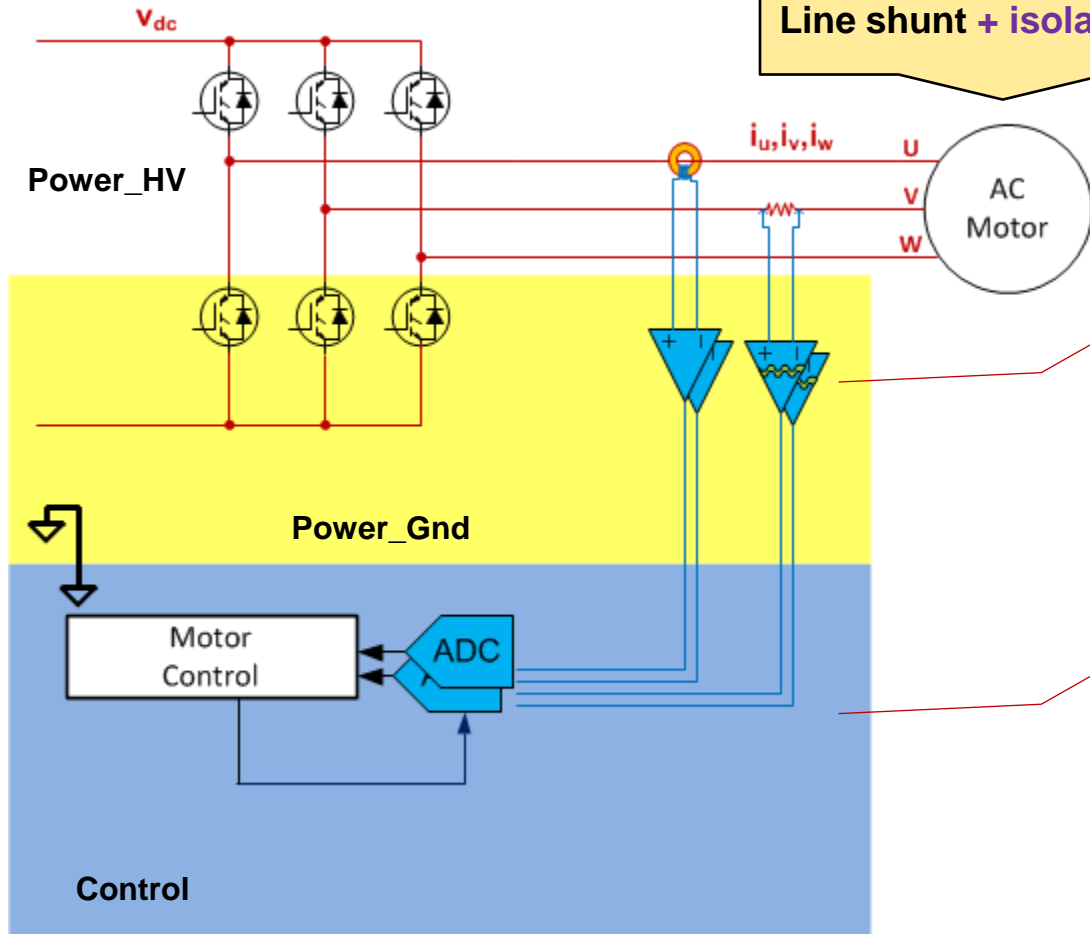

High CM Diff amp
 OR
 Isolated amp + ADC.

ADC more likely to be embedded.

Control Connected to Safety Earth

Safety Isolated current feedback

'Higher' end

Line current feedback options:
 Isolated sensor + amp + SAR ADC
 Isolated sensor + ($\Sigma\Delta$) Mod + SINC3
 Line shunt + isolation amp + SAR ADC
 Line shunt + isolating ADC + SINC3 ($\Sigma\Delta$)

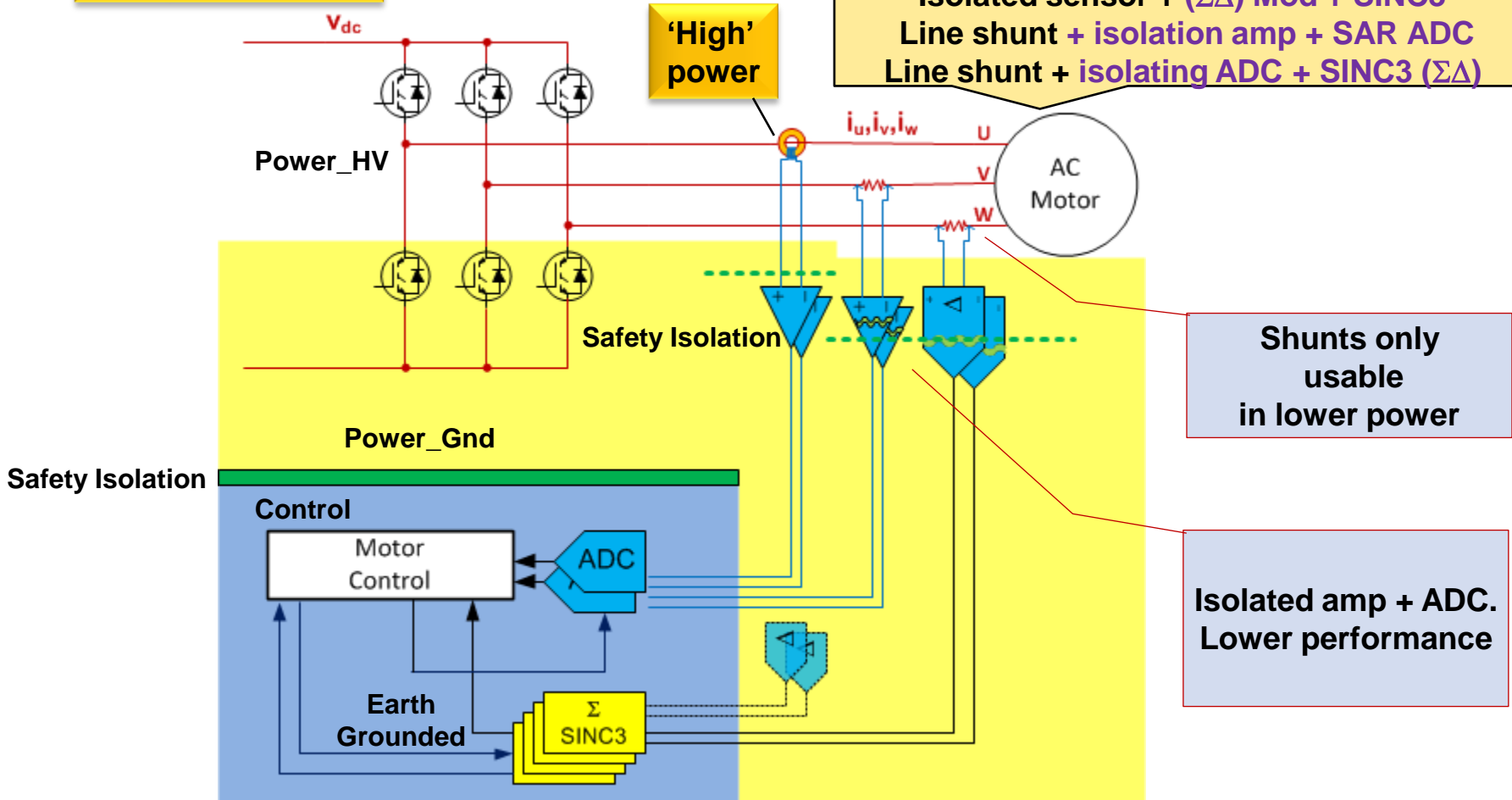

Power Grounding and Gate Drive circuits

Controller connected to power GND

- Level shifting (LS) gate driver circuits can be used

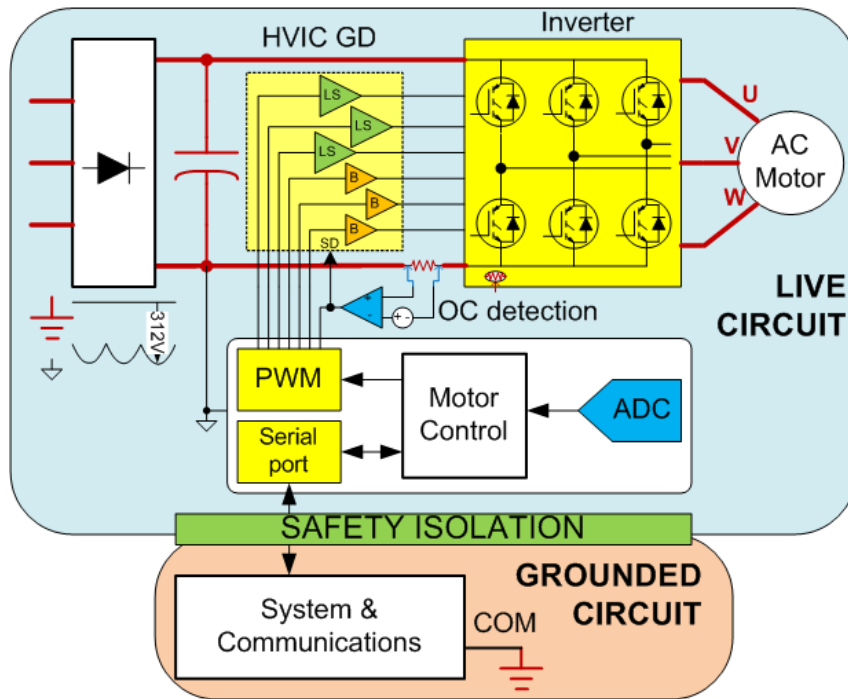

Controller connected to EARTH

- Safety isolated gate drivers MUST be used

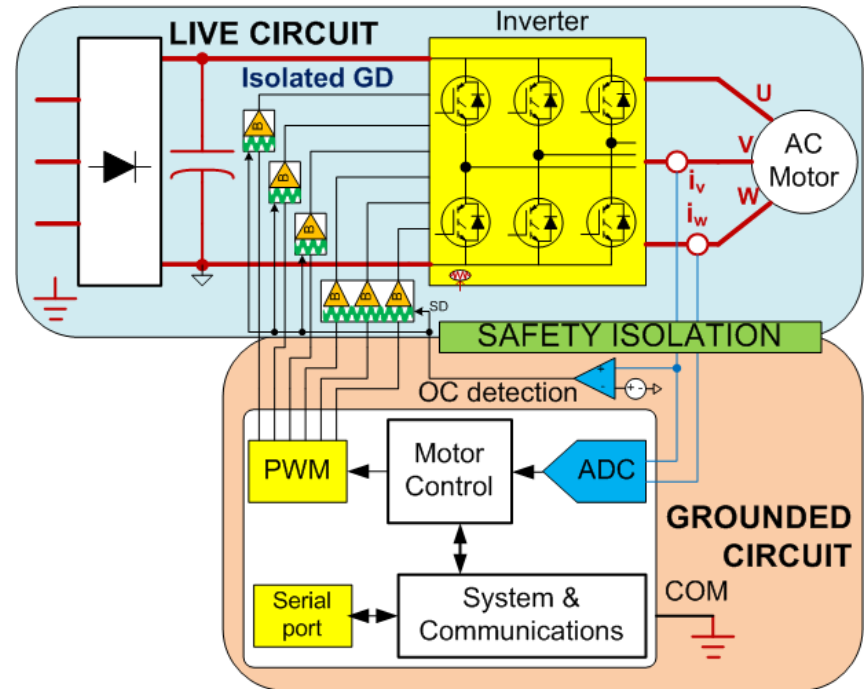

Influencing Factors on Architecture / System Build

Key Factors to consider

- ◆ **Understanding the Isolation Demand at Gate driver/ current sense node**
 - Review key isolation terminology
 - **Isolated Current Sensing with *i*Coupler Technology**
 - ◆ Rated Motor Voltages -> Bus Voltages -> Continuous Working Voltage

- ◆ **Industry Standards**
 - Standards Bodies and Agencies
 - System level and Component level Standards
 - *i*Coupler product usage as related to standards and component choice.
 - IEC60747-17: version of IEC60747-5-5 for non opto isolators

Isolation Terminology

Voltage/ Time Related Breakdown Ratings

Working Voltage

- Continuous operation, AC or DC
- Specified RMS or Pk.
- ADI *iCoupler* technology offers up to 1250Vpk.
- Voltage at which insulation lifetime is specified

Insulation Lifetime

- Specifies how long insulation will function at the working voltage
- Measure of long-term reliability

Withstand Voltage

- Ability to withstand up to 60secs of V_{ISO} , high voltage.
- Differentiating Data Sheet Spec
 - ◆ 1 kV_{RMS}, 2.5 kV_{RMS}, and 5kV_{RMS}.
 - 100% tested in production
 - Standard test of insulation integrity
 - Alternatively specified as peak

Surge

- Short-term high-voltage pulse
 - ◆ Simulating Lightning Strike (non-repetitive transients)

Withstand Voltage Measurement

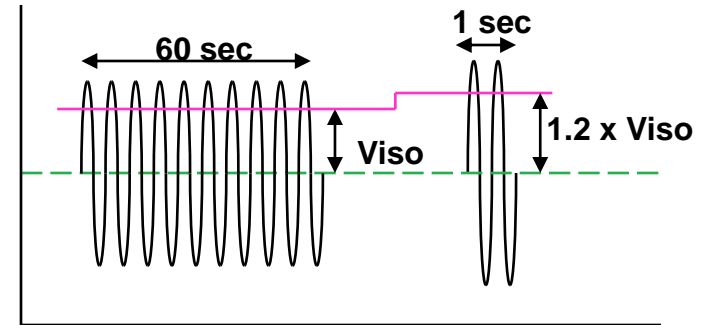

Surge Voltage Measurement

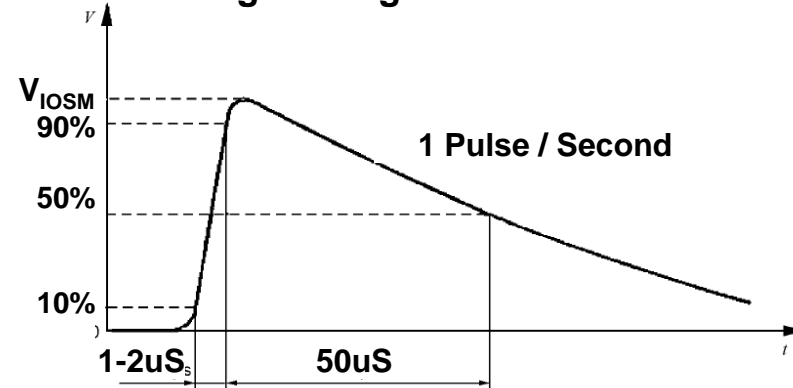

Power/Signal/Control Isolation Strategies

Motor control processor ground connected to **DC bus common**

Motor control processor ground connected to **Earth**

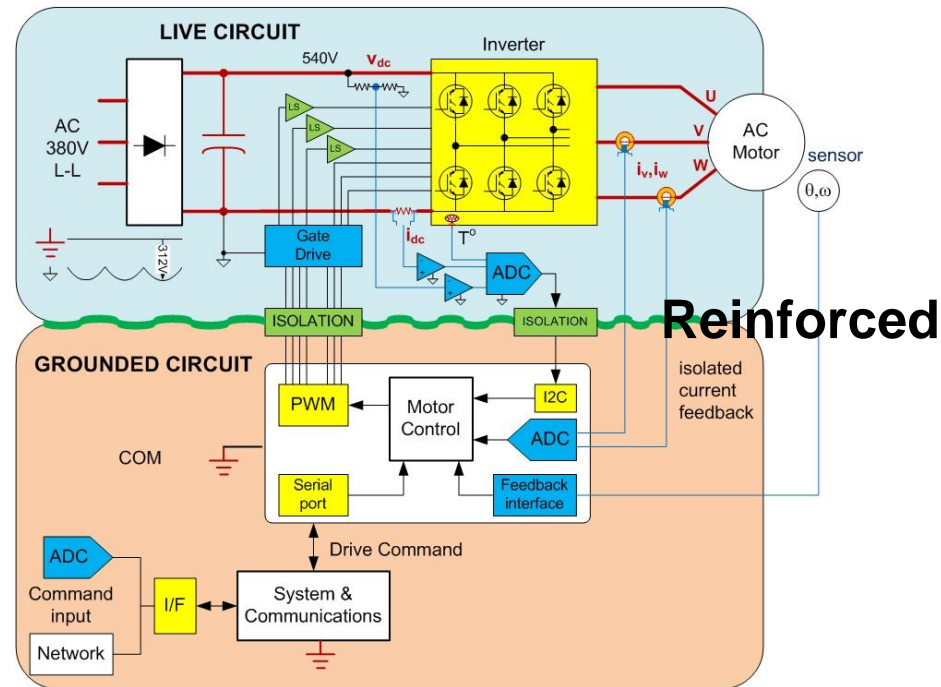
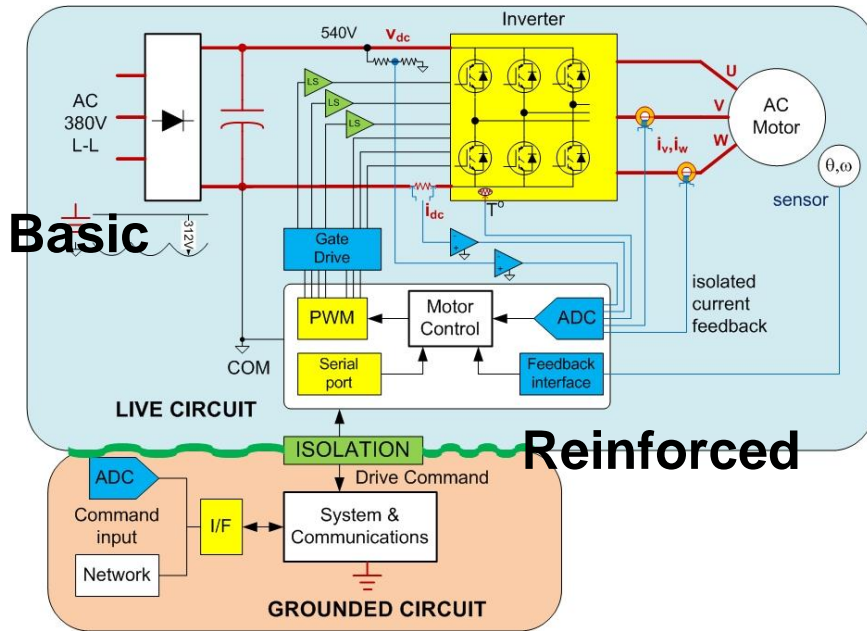

Working Voltage at Current Sense Node

- ◆ Inverter outputs switch between $+V_{DC}$ and DC bus common
- ◆ Shunt voltage signal has common mode voltage: $V_{CM} = 0 - V_{dc}$ w.r.t earth @ f_{PWM}

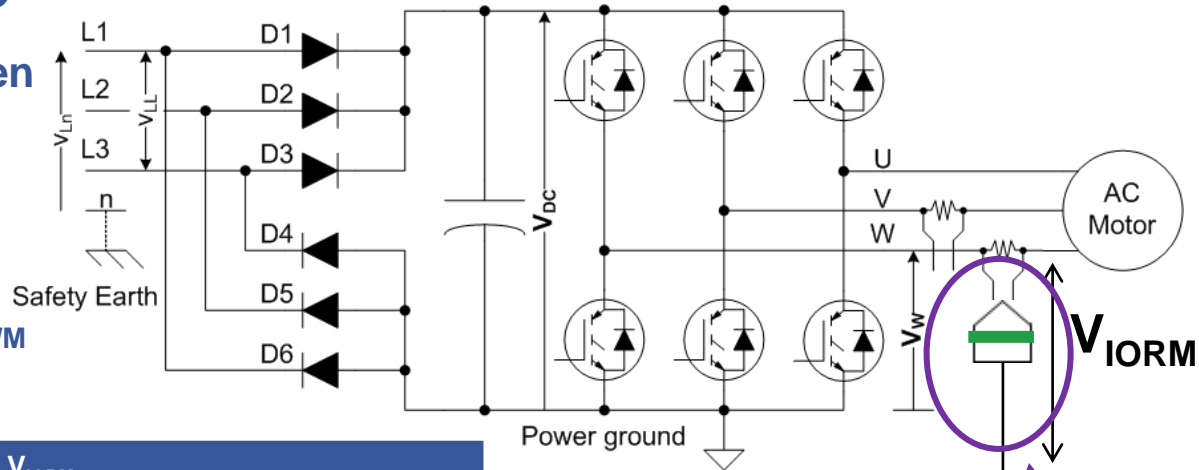

e.g. AD7403

Drive		V_{DC}	V_{IORM} Power gnd = Control COM	V_{IORM} Power gnd \neq Control COM	
				neutral gnd AC ($V_{DC}/\sqrt{3}$)	(corner gnd)
220V _{LN}	1-ph ($V_{LN} * \sqrt{2}$)	310V	310V	+310V /-310V	+310V /-310V
380V _{LL}	3-ph($V_{LL} * \sqrt{2}$)	540V	540V	+310V /-310V	+540V /-540V
400V _{LL}	3-ph($V_{LL} * \sqrt{2}$)	565V	565V	+326V /-326V	+565V /-565V
690	3-ph($V_{LL} * \sqrt{2}$)	975V	975V	+563V /-563V	+975V /-975V

Theoretical

Supply Margins
Back EMF
Switching transients

Distributed System
PFC
Transformer

Using *iCoupler*[®] Technology in Motor Drive Systems

The Motor Drive Standard and Components



61800-5-1

1 Scope

The scope of this part of IEC 61800 does not include devices used as component parts of a *PDS* if they comply with the safety requirements of a relevant product standard for the same environment. For example, motors used in *PDS* shall comply with the relevant parts of IEC 60034.

4.3.6.8 Solid insulation

4.3.6.8.1 General

Materials selected for solid insulation shall be able to withstand the stresses occurring. These include mechanical, electrical, thermal and climatic stresses which are to be expected in normal use. Insulation materials shall also be resistant to ageing during the *expected lifetime* of the *PDS*.

Components that comply with a relevant product standard which provides equivalent requirements to those of this standard do not require separate evaluation. Assemblies containing such components shall be tested according to the requirements of this standard.

- ◆ **This standard does not address the assessment of components**
- ◆ **Product standards with equivalent requirements can be used**

Insulation System Design Goal

- 1) **Make a safe insulation system**
 - a) Know the stresses across each barrier
 - b) Dimension the creepage and clearance
 - c) Verify insulation or component is suited to the task over lifetime

- 2) **Optimize the system for performance and cost**
 - a) Architect the system to minimize the stress on each barrier
 - b) Apply overvoltage class reduction where appropriate
 - c) Minimize the highest stress interfaces

Determining Insulation Requirements

◆ DVC – Decisive Voltage Classification

- Used to determine the level of protection between circuits

◆ OVC – Over Voltage Category

- Determines the expected overvoltage due to the installation
- Rated for highest Pulse, Overvoltage, or Repetitive peak

DVC	ACrms	ACpeak	DCmean
A	25	35.4	60
B	50	71	120
C	1000	4500	1500
D	>1000	>4500	>1500

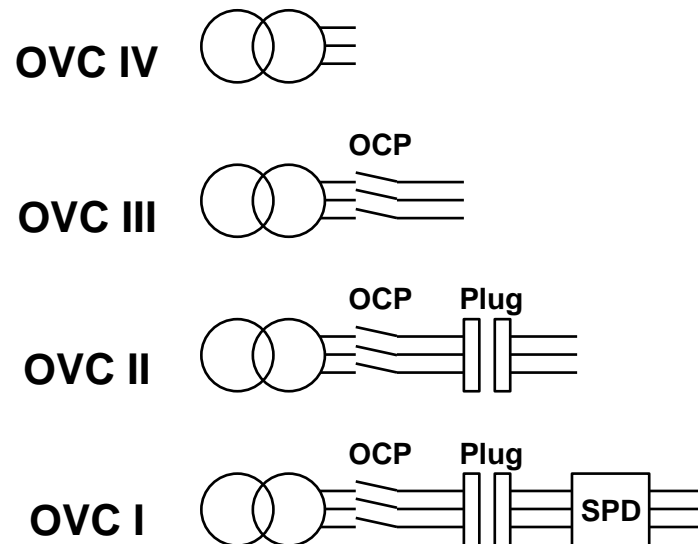

Using Decisive Voltage Category

DVC Of Circuit Under Consideration	Insulation Of Adjacent Circuit of DVC:			
	A	B	C	D
A	f	b	b/p	p
B		b	b/p	p
C			b	p
D				p

f = Functional Insulation
 b = Basic insulation
 p = Protective (Reinforced) insulation

- ◆ Adjacent circuits protection levels are specified
- ◆ Insulation to an earthed conductive enclosure is always Basic
- ◆ Insulation to accessible conductive parts is always Protective (Reinforced)

Grounding Schemes

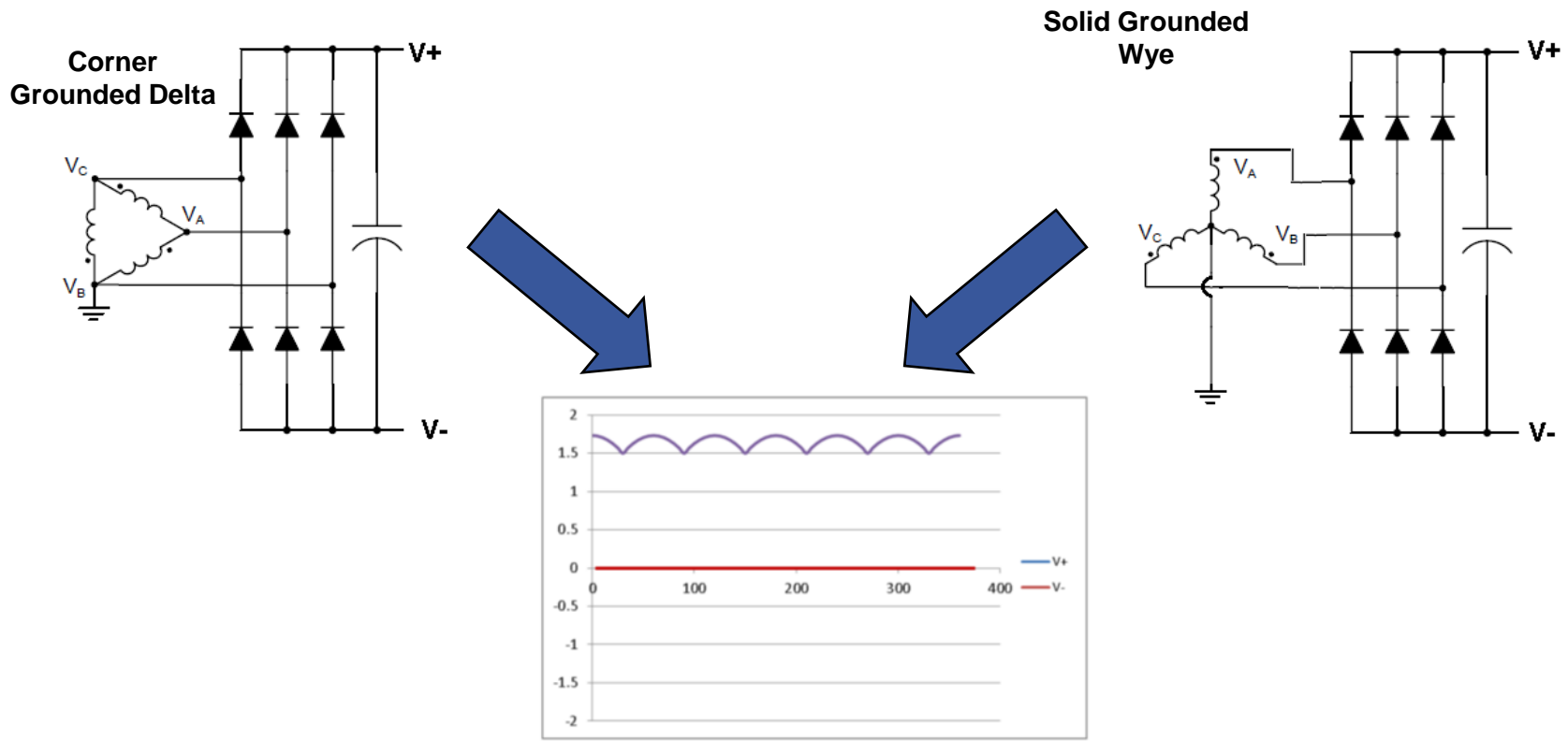

- ◆ The grounding connection for the service has no impact on the Bus Voltage
- ◆ Bus voltage is $\sim \sqrt{2} * \text{Peak Phase-Phase } V_{PP} \text{ voltage}$

Effect of System Grounding

Corner Grounded Delta

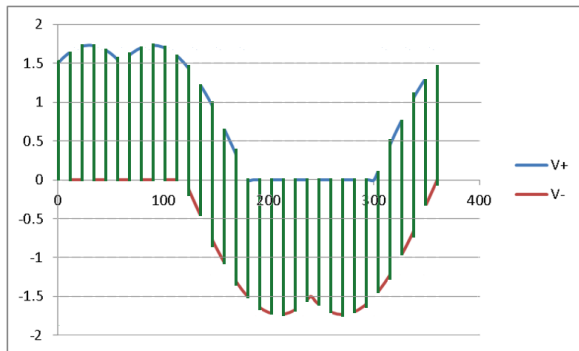
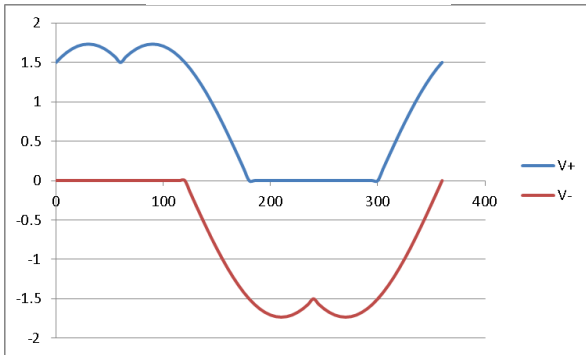
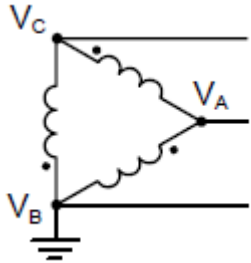

Solid Grounded Wye

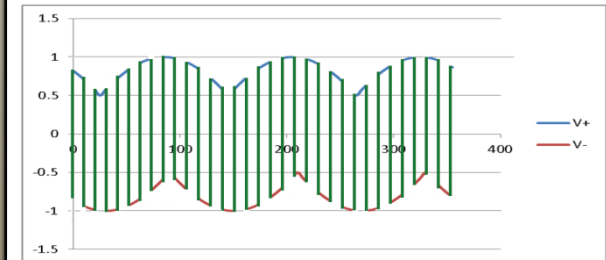
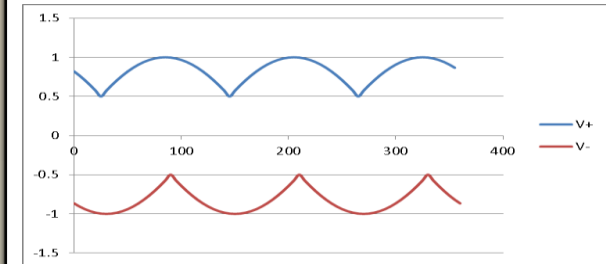
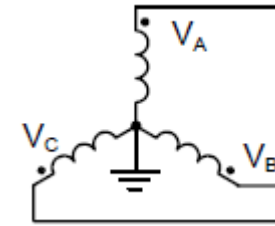

◆ The voltage with respect to ground is significantly different

◆ Diagrams

- 1) Transformer Connection
- 2) Rectifier V+/V- output WRT ground
- 3) Inverter Switching signal

◆ P-P voltage for Corner grounded Delta is $\sqrt{3}$ times larger than the solid grounded Wye

Functional/Reinforced Architecture

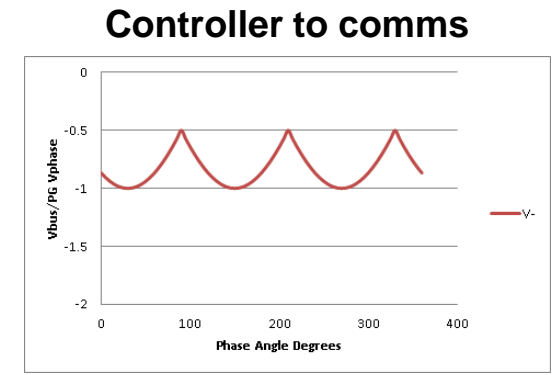
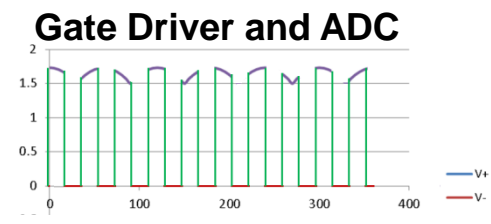
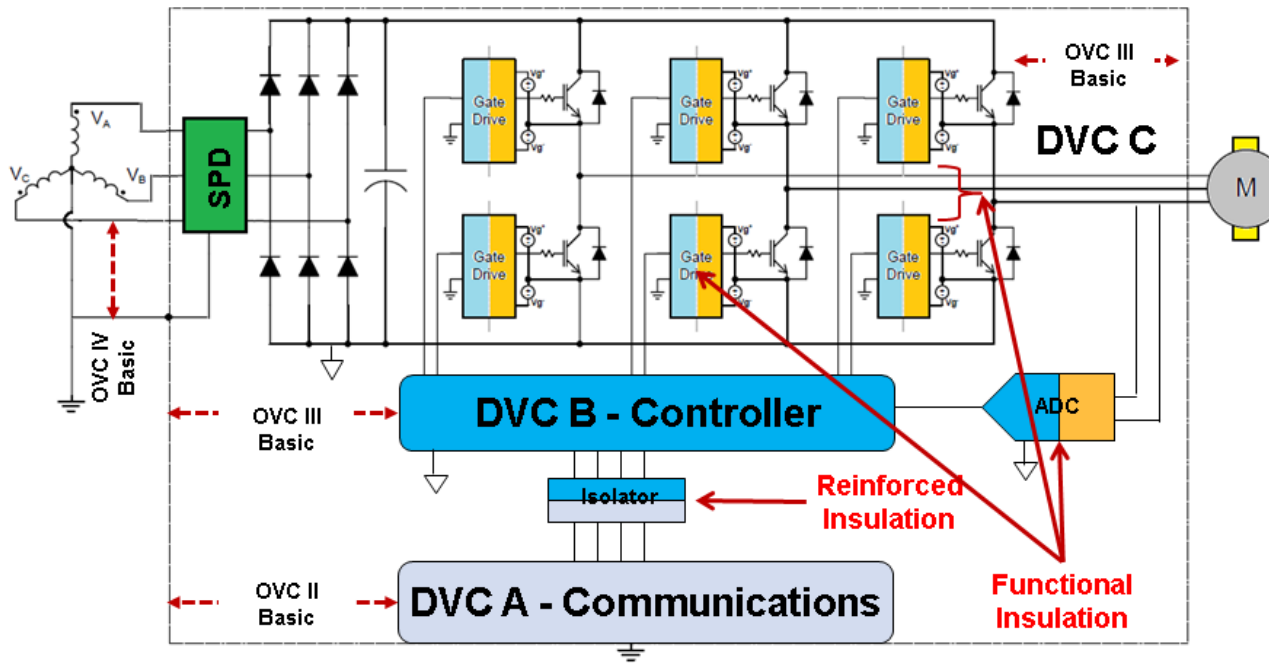

- ◆ The controller and DC bus share a reference
- ◆ The gate driver and sensors see only the DC bus voltage as the inverter switches
- ◆ The Controller/Communications interface sees only the Safety Ground to V- voltage

Basic/Basic Architecture

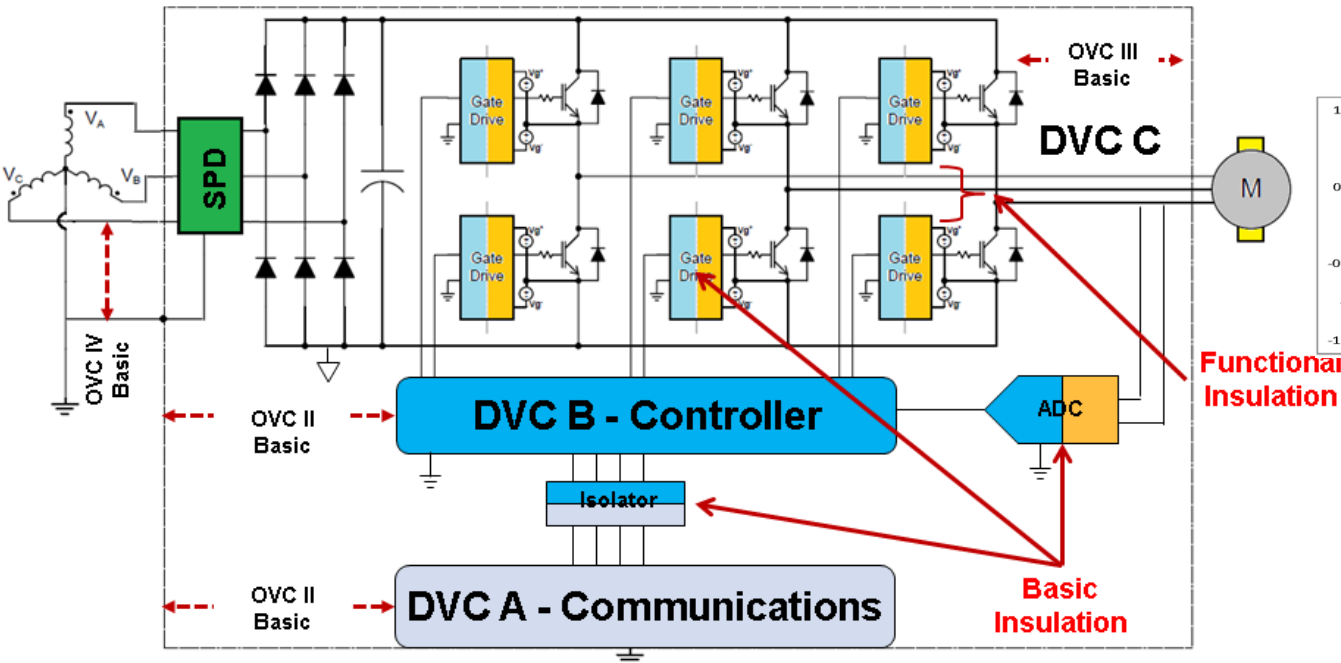

Gate Driver and ADC

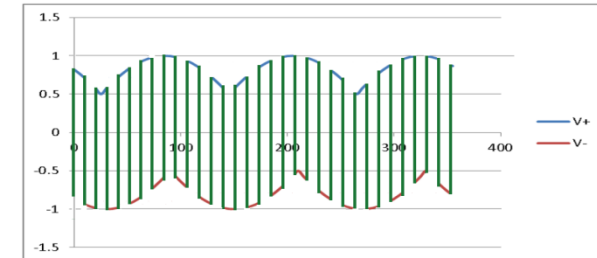

- ◆ The controller and DC bus no longer share a reference
- ◆ The gate driver and sensors see the DC bus voltage as the inverter switches superimposed on the Ground to V- Voltage
- ◆ The Controller/Communications interface sees almost no voltage, the isolation is for fault protection only

Reinforced Architecture

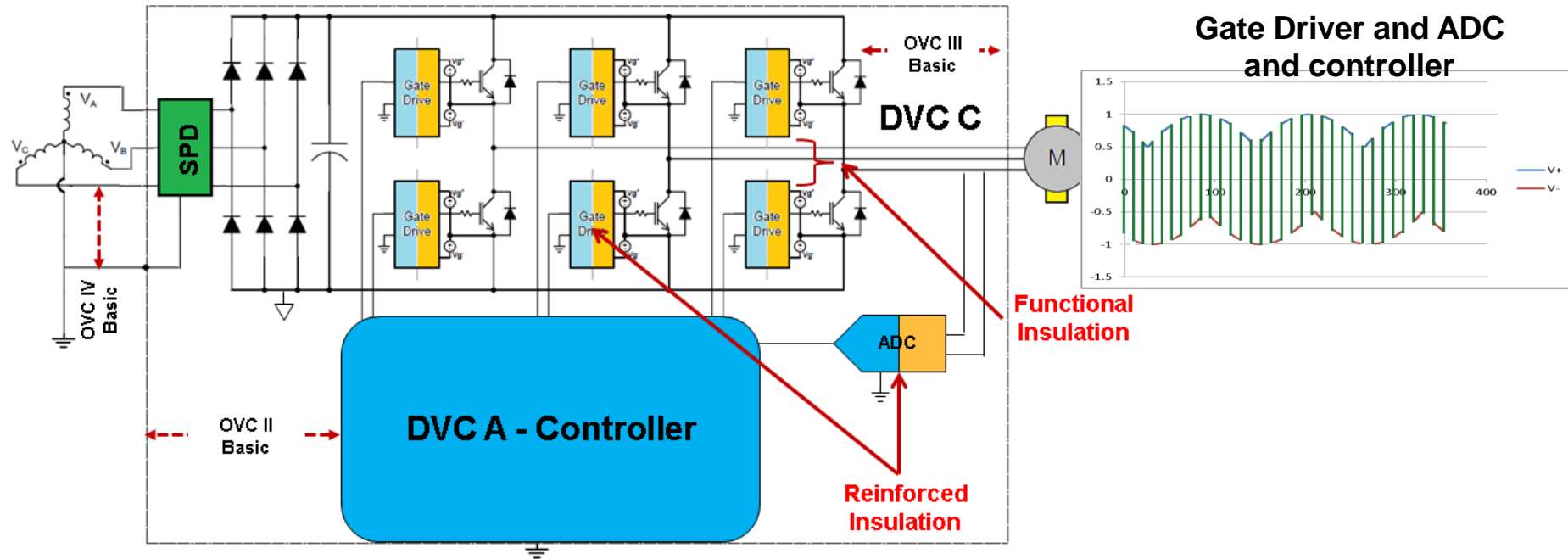

- ◆ The controller and DC bus no longer share a reference
- ◆ The gate driver and sensors see the DC bus voltage as the inverter switches superimposed on the Ground to V- Voltage
- ◆ This high voltage interface is now reinforced requiring higher surge ratings for components and longer creepage and clearance

Creepage

- ◆ Creepage is based on the RMS working voltage
- ◆ Modifiers
 - Material Group
 - Pollution Degree
 - Material type
- ◆ Components can use PCB spacing up to 1250Vrms

- ◆ Pollution degree 2.
 - Normally only nonconductive pollution occurs. Occasionally a temporary conductivity caused by condensation must be expected

Table 10 – Creepage distances (mm)

Column 1	2	3	4	5	6	7	8	9	10	11	12
Working voltage (r.m.s.)	PWBs ^a		Other insulators								
	Pollution degree		Pollution degree						Pollution degree		
(V)	1	2	1	2			3				
	b	c	b	Insulating material group			Insulating material group				
				I	II	IIIa	IIIb	I	II	IIIa	IIIb
200											
250				1,25	1,8	2,5					
320		1,0									

NOTE Interpolation is permitted.

^a These columns also apply to components and parts on PWBs, and to other creepage distances with a

^d Values for creepage distances are not determined for this range.

^e Insulating materials of group IIIb are not normally recommended for pollution degree 3 above 630V.

^f above 1 250 V use the values from columns 4 to 11, as appropriate.

^b All material groups

^c All material groups except IIIb

Comparative Tracking Index (CTI) for Package Material

Material Group	Voltage Range
I	CTI>600
II	600>CTI>400
IIIa	400>CTI>175
IIIb	175>CTI>100

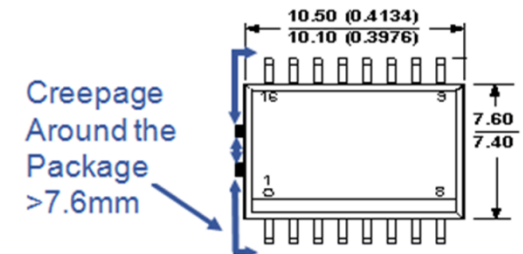

Determining Clearance

Table 7 – Insulation voltage for low voltage circuits

Column 1	2	3	4	5	6
System voltage (4.3.6.2.1) (V)	Impulse voltage (V)				Temporary overvoltage (crest value / r.m.s.) ^a (V)
	Overvoltage category				
	I	II	III	IV	
≤ 50					
100					
150					
300		2 500	4 000	6 000	2 120 / 1 500
600			6 000		2 550 / 1 800
1 000					

◆ **Pollution degree 2.**

- Normally only nonconductive pollution occurs. Occasionally a temporary conductivity caused by condensation must be expected

◆ Clearance requirements are set by the peak voltages seen at an interface

◆ Set by worst case of Impulse, Temporary Overvoltage or peak working voltage

◆ Reinforced clearance is one column higher, or 1.6x the transient voltages

Table 9 – Clearance distances

Column 1	2	3	4	5	6
Impulse voltage (Table 7, Table 8, 4.3.6.3) (V)	Temporary overvoltage (crest value) for determining insulation between surroundings and circuits or Working voltage (recurring peak) for determining functional insulation (V)	Working voltage (recurring peak) for determining insulation between surroundings and circuits (V)	Minimum clearance mm		
			Pollution degree		
			1	2	3
	960	600		0,50	
	1 600	1 000		1,5	
4 000		1 000		3,0	
6 000				5,5	
8 000				8,0	

Reinforced
Basic

Functional

NOTE 1 Interpolation is permitted.

NOTE 2 Examples of clearance distances are given in Annex C.

NOTE 3 Clearances for temporary overvoltage and working voltage have been derived from Table A.1 of IEC 60664-1. In column 2, the voltage is approximately 80 % of the withstand voltage; in column 3, the voltage is approximately 50 % of the withstand voltage.

Functional Creepage

Creepage
Around the
Package
>7.6mm

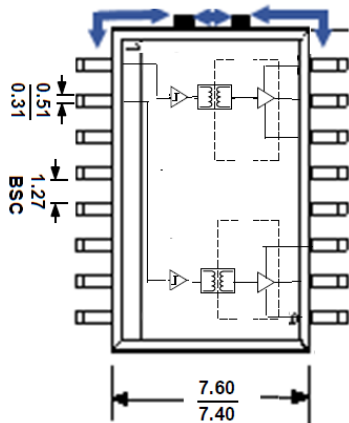

3 ea.
0.86mm
Creepage

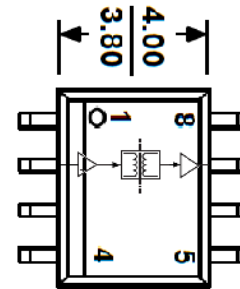

Arbitrary
Creepage

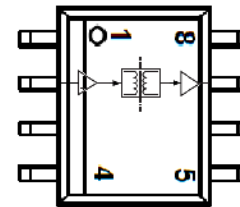

- ◆ In half bridge gate drivers, a single pin spacing is adequate for 225V
- ◆ Many standards do not require creepage rules for functional insulation
- ◆ If more creepage is required, single channel gate drivers can be used

What makes a part Reinforced

- ◆ **Determining if a component meets reinforced requirements**
 - **Physical Construction – twice as much**
 - ◆ Thickness
 - ◆ Material properties
 - ◆ Multiple Layers
 - **Electrical evaluation – much lower probability of failure**
 - ◆ Accelerated lifetime testing
 - ◆ EOL failure rates (Reinforce= Basic²)
 - ◆ Type Testing

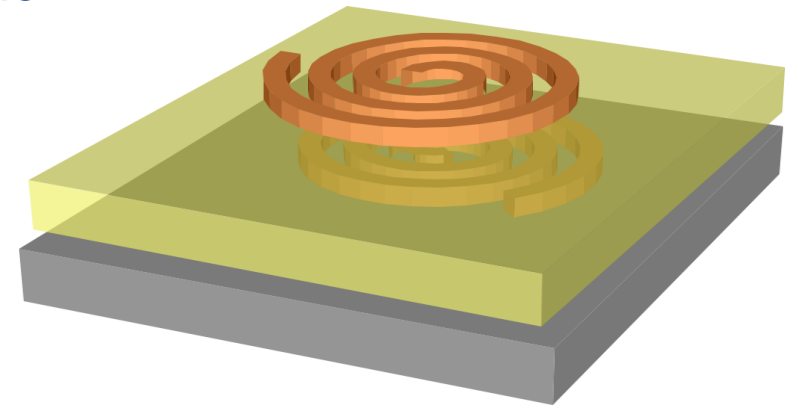

Reinforced Insulation

- ◆ **Double insulation is created with independent basic and supplemental insulation applied to the same interface**
 - This is not always practical when high precision or high speed signals need to pass across the isolation barrier
 - Analog degradation and digital timing errors accumulate with each barrier crossing
- ◆ **Reinforced insulation allows a single insulation system to be classified as robust as double insulation**
 - **Components may need to meet additional structural requirements**
 - ◆ Minimum Thickness of solid insulation
 - ◆ Multiple layers of film insulation
 - ◆ Increased creepage and clearance
 - **Additional type testing during qualification**
 - ◆ Thermal Cycling
 - ◆ Surge
 - **Additional Assembly line tests**
 - ◆ Partial Discharge

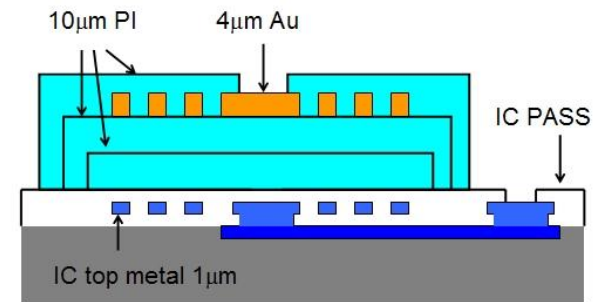

Polyimide Insulation Meets 10 kVpk Surge

- ◆ Short-term high-voltage pulse simulates a lightning strike
- ◆ Insulation must pass 10 kVpk minimum surge for Reinforced Insulation
 - ◆ VDE 0884-10
 - ◆ IEC60747-5-5

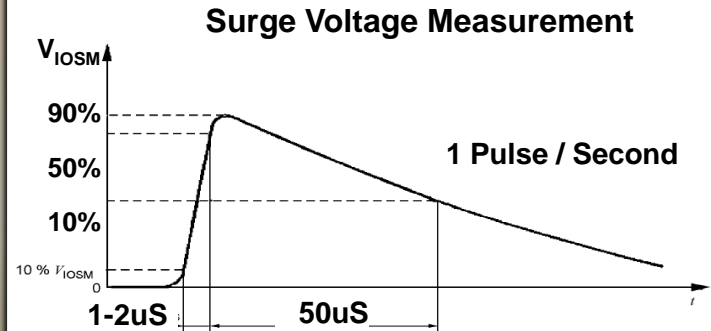

SiO₂ surge failure

Material	Isolator	Result
Epoxy	Optocoupler	Pass
Polyimide	<i>i</i> Coupler Digital Isolator	Pass
SiO ₂	Other Digital Isolator	Fail ¹

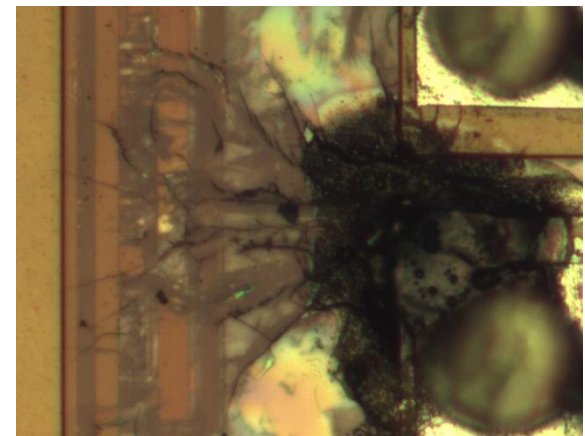

Note 1: High speed >2Mbps

Lifetime Curves

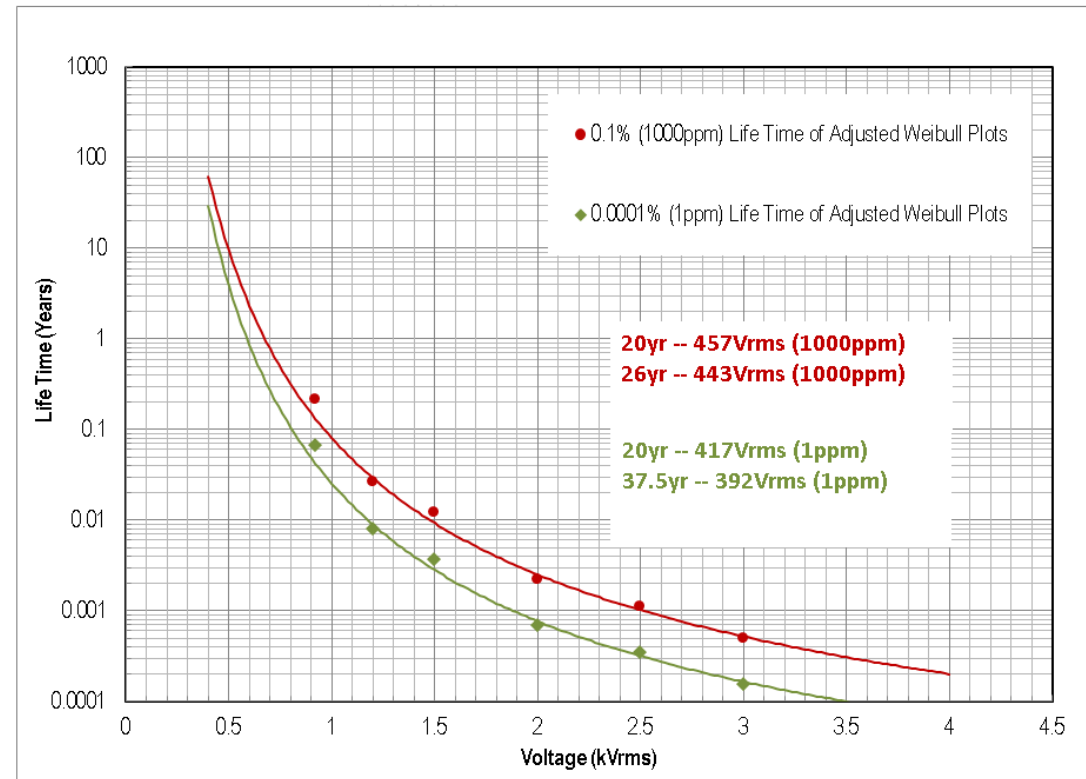
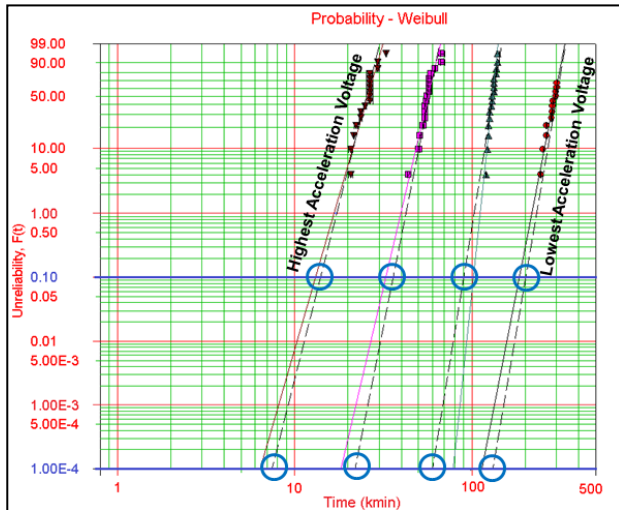

- ◆ Lifetime curve shapes are established based on materials
- ◆ The curve is fit to the data
- ◆ Lifetime is extrapolated back to the working voltage

Component Standard for Non-Opto Isolators

- ◆ **VDE developed a non-Opto version of the IEC60747-5 standard**
- ◆ **VDE 0884-10 Ed 1**
 - Approved 2006
 - Added Characterization
 - Reinforced Insulation Only
 - Unacceptable to IEC
- ◆ **VDE 0884-10 Ed2**
 - Approved July 2014
 - Changes based on IEC feedback
- ◆ **IEC 60747-17 draft submitted**
 - July 2014
 - 3 Years Approval Cycle
- ◆ **DIN V VDE V 0884-10 Ed2**
 - Being translated into German
 - Applies to Germany only
 - Can be used as IEC equivalent

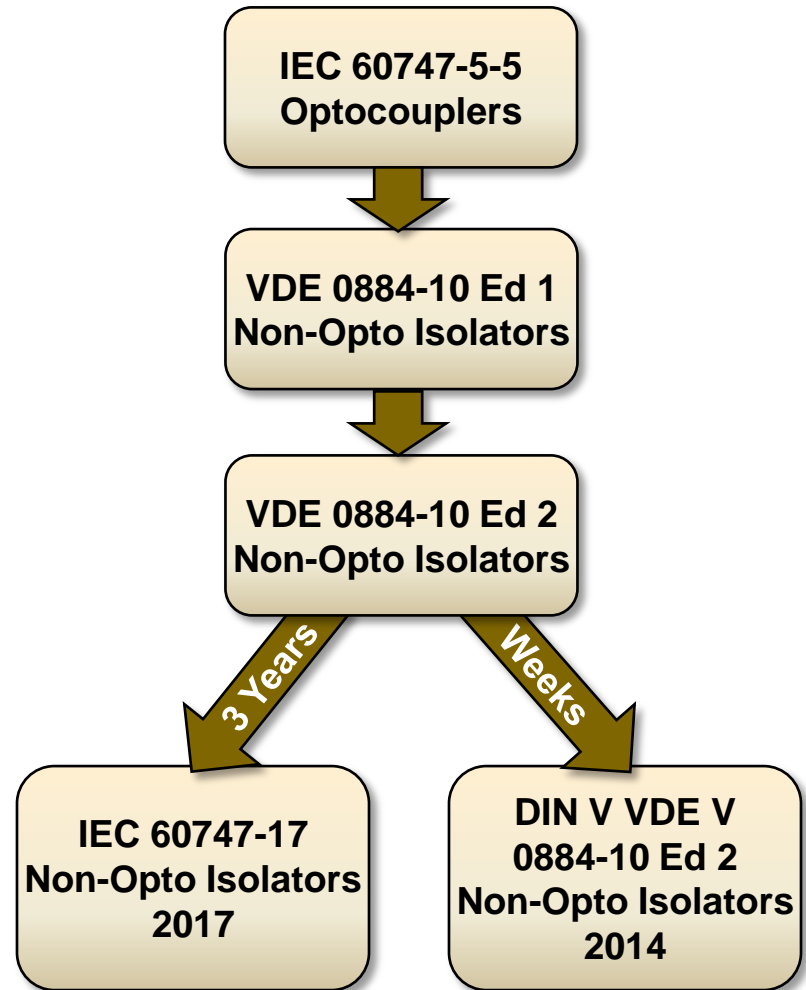

Insulation lifetime

- ◆ **The new standard assumes known construction**
- ◆ **Characterization through test**
- ◆ **There are two major additions**
 - **Lifetime Characterization at 50/60Hz Sinusoidal**
 - ◆ Curves generated at two temperatures
 - ◆ 1.2x Margin on working voltage
 - ◆ 1.3x Lifetime Margin @ 1000PPM for Basic
 - ◆ 1.86x Lifetime Margin @ 1PPM for Reinforced
 - ◆ The same methodology is applicable for any conditions
 - **Accelerated Life Test**
 - ◆ Components are run to 80% of predicted accelerated lifetime
 - ◆ Isolation is verified at end of life

Summary

In this seminar we have discussed various Motor control architectures focusing on the isolation required to implement them. The options available to meet these challenges has expanded greatly with the availability of digital isolators for communications, gate drive and analog to digital sensor interfaces.

In support of the digital isolator technologies, we have looked into the isolation consequences of the various architectures and how they can be addressed in the regulatory framework.

Thank you for your attendance.

Thank You For Watching

View Additional Webcasts at
www.analog.com/webcasts